



THE BOOLEAN

**Snapshots of Postgraduate Research
at University College Cork**

2015

Contents

Introduction by Professor Liam Marnane, Dean of Graduate Studies	v
Rehan Ahmed: <i>Automated System for Detecting Neonatal Brain Injuries</i>	1
Evin Allen: <i>Smarter, faster, better vaccines</i>	7
Wejdan M. Alsadi: <i>I see what is said: The interaction between multimodal metaphors and intertextuality in cartoons</i>	13
Hazzaa Naif Alshareef: <i>Introducing mobile cloud technology into m-health to deliver better care/support in case of emergencies</i>	20
Joveria Baig: <i>Tired of slow internet? Lasers to the rescue</i>	27
Margaret Buckley: <i>Welfare Provision for the over 50s in Limerick City, 1875 to 1925</i>	33
Sharon Louise Cadogan: <i>Testing times ahead? An exploration of laboratory use in Primary Care</i>	37
Paul Anthony Cahill: <i>Smart Cities — How can we get bridges talking?</i>	42
Rudi Capra: <i>Blue mountains, empty waters: the evolution of Chinese landscape painting under the influence of Chan Buddhism</i>	48
Yen-Chi Wu: <i>John McGahern and the temporalities of modernity</i>	55
James Cully: <i>Daylight saving for the brain</i>	60
Shane Duggan: <i>Photons in the machine</i>	65
Loretta Goff: <i>Hyphenating Ireland and America: the contemporary construction of identity, film, and media in a hybrid space</i>	70
H. Pierre Hsieh: <i>What do the translator and the grocery shopper have in common? Well, everything!</i>	74

Blazej Kaucz: <i>Legal textbooks — the reflection of socio-legal reality</i>	79
Niamh Kavanagh: <i>The internet is not limitless</i>	81
Niamh Kehoe: <i>Holy humour: Vernacular saints' lives in England, 900 — 1300</i>	87
James Keogh: <i>Can we ever have a 'right to die'? A reflective consideration of assisted suicide in Ireland</i>	92
Alison Elizabeth Killilea: <i>The Grendel-kin: From Beowulf to the 21st century</i>	97
Annarita Magliacane: <i>"I am going abroad to study English": language learning beyond words and grammar</i>	102
Alan McCarthy: <i>The censorship and suppression of Cork's nationalist and loyalist newspapers during the Irish Revolution, 1916-1923</i>	108
Zamzaliza Abdul Mulud: <i>"What will happen when I can no longer cope?" Burden in caring for people with severe mental illness</i>	112
Fiona Edwards Murphy: <i>To bee, or not to bee? Honey bees, Boolean logic, bits and information</i>	117
Lisa Murphy: <i>The Mental Time Traveller: Considering the Future Consequences of Present Day Behaviours</i>	123
Margaret M. Murphy: <i>Rainbow of hope after the storm: Couples' experiences of pregnancy after stillbirth</i>	128
Jeanna Ní Riordáin: <i>'Victor Hugo, the Irish 'Misérables, and Fenian women in the nineteenth-century'</i>	131
Mary G. O'Brien: <i>Photography: My New Score</i>	136
Eoin O'Callaghan: <i>A demanding form: William Faulkner and the short story</i>	142
Karen O'Callaghan: <i>Nutrition and Health in Mothers and Infants — Update from the Vitamin D Research Group</i>	147
Patricia O'Connor: <i>Marginalised Texts: The Old English Marginalia and the Old English Bede in Cambridge, Corpus Christi College 41.</i>	152
Deirdre O'Donnell: <i>Why is the Shaky Bridge so Shaky?</i>	158
Meadhbh O'Halloran : <i>The Medieval World on the Renaissance Stage</i>	163
Siobhán O'Neill: <i>Technology and Teenagers: No Time to Sleep?</i>	166

Brian O'Reilly: <i>The European Public Prosecutor's Office: An institution built on sand?</i>	171
Jane Maeve O' Sullivan: <i>Silence please!</i>	175
Lloyd Frank Philpott: <i>The Secret Lives of Postnatally Depressed Dads</i>	179
Sinead Power: <i>Shave of the brave: Self-concept in chemotherapy-induced hair loss</i>	183
Silvino Jose Antuña Presa: <i>Illuminating the future with LEDs</i>	188
Wissam Abdel Samad: <i>STEMming the tide of student non-engagement</i>	193
Mary Catherine Gallagher: <i>Alien versus native: The fight for free space</i>	199
Sander van Lanen: <i>Surviving in uncertainty: experiences of recession in Knocknaheeny, Cork</i>	204

SNAPSHOTS OF POSTGRADUATE
RESEARCH AT UNIVERSITY COLLEGE
CORK

Introduction

For any research student, a key skill is the ability to communicate results and more importantly the impact of their research to a wide audience. In the year that we in University College Cork celebrate the 200th anniversary of George Boole, it is our pleasure to introduce the fifth volume of the Boolean, which presents snapshots of Postgraduate Research at University College Cork. In The Boolean we aim to promote the calibre of digital thinking and diverse research projects at our University.

In order to have their articles included in The Boolean, authors have to describe their research using non-specialist language, so that the wider community can understand it. We congratulate the authors on their efforts and we particularly thank the students and staff of UCC, listed on the following page, who reviewed the articles. We hope that readers enjoy the articles and get a greater understanding of the breath of research being undertaken at UCC.

'The Boolean' Team — November 2015

Editor

Professor Liam Marnane, Dean of Graduate Studies

Editorial Assistant

Anne-Marie Scarry, Graduate Studies Office

Reviewers

Dr Teresa Barbosa, School of Pharmacy

Dr Joe Bogue, Department of Food Business and Development

Dr Jane Bourke, School of Economics

Dr Colman Casey, College of Medicine and Health

Dympna Daly, School of Education

Niamh Denihan, Department of Paediatrics & Child Health

Dr Samantha Dockray, School of Applied Psychology

Maria Donovan, School of Pharmacy

Dr Barbara Doyle, School of Biological Earth & Environmental Sciences

Prof Joseph Feller, Business Information Systems

Dr Eoin Fleming, School of Biochemistry and Cell Biology
Christine Gaffney, School of Applied Social Studies
James Edward Gallagher, School of Pharmacy
Anushka Gangnaik, Department of Chemistry
Emilie Ghio, School of Law
Dr Brendan Griffin, School of Pharmacy
Ciara Harty, School of Medicine
Prof Mark Hutchinson, Department of Accounting, Finance and Information Systems
Dr Aislinn Joy, School of Medicine
Dr JJ Keating, School of Pharmacy
Dr Elizabeth Kiely, School of Applied Social Studies
Nina Konstantinidou, Department of Microbiology
Dr Patricia Leahy — Warren, School of Nursing and Midwifery
Laura Lee, School of Applied Psychology
Dr Eoin Lettice, School of Biological Earth & Environmental Sciences
Marie Luise Theuerkauf, Department of Early and Medieval Irish
Dr Orla Lynch, Department of Sociology
Susan Martin, School of Applied Social Studies
Aoife Mc Gillicuddy, School of Pharmacy
Carol McCarthy, School of Pharmacy
Dr Florence McCarthy, Department of Chemistry
Dr Pat Meere, School of Biological Earth & Environmental Sciences
Karen Moloney, School of English
Kellie Morrissey, School of Applied Psychology
Dr Kevin Murphy, Department of Anatomy and Neuroscience
Dr Orla Murphy, School of English
Dr Deirdre Murray, Department of Paediatrics & Child Health
Dr Mervyn O'Driscoll, School of History
Prof Ken O'Halloran, Department of Physiology

Andrew O’Leary, Department of Physiology

Dr Conor O’Mahony, School of Law

Dr Maureen O’Connor, School of English

Karen O’Leary, School of Applied Psychology

Dr Jacqui O’Riordan, School of Applied Social Studies

Joseph O’Shea, School of Pharmacy

Dr Niall O’Sullivan, School of Economics

Kevin O’Sullivan, School of Law

Marc O’Sullivan, Department of Paediatrics & Child Health

Prof. Ronan O’Sullivan, Department of Surgery

Rosemary O’Sullivan, School of Law

Elliot Payne, School of Law

Laura Pomeroy, School of English

Dr Ruth Ramsay, School of Biological Earth & Environmental Sciences

Dr Brendan Richardson, Department of Management and Marketing

Dr Ken Rooney, School of English

Eileen Russell, School of Biological Earth & Environmental Sciences

Dr David Sammon, Business Information Systems

Steve Warren, School of Applied Psychology

The Boolean Team also wish to thank the following people for their invaluable assistance.

- Áine Flynn, Graduate Studies Office
- Peter Flynn, IT Services
- Breda Herlihy, Boole Library
- Catherine Maguire, UCC Academy
- Gretta McCarthy, Academic Secretariat

For comments or queries, please contact boolean@ucc.ie

SNAPSHOTS OF POSTGRADUATE
RESEARCH AT UNIVERSITY COLLEGE
CORK

Automated System for Detecting Neonatal Brain Injuries

Rehan Ahmed

Dept. of Electrical and Electronics Engineering,, UCC

“The most dangerous journey a human ever makes in his life is from the womb of his mother to the outer world.” (Lord Robert Winston)

The birth of a baby is a moment, enjoyed by many parents. However, in some rare cases these moments get shadowed due to the poor health of the new-born. Almost 1 in 5 pregnancies gets complicated and around 10% of all babies require admission to the special care unit due to problems of delivery.

Brain injury at the time of birth, due to lack of oxygen or blood in the brain, may cause neural dysfunctions or death in severe cases. In fact, it accounts for a third of all neonatal deaths globally and is the most common cause of long term severe neurological disability in neonates. Therefore, it is very important to diagnose and then treat the neonates with these brain injuries as early as possible.



Figure 1: (a) A neonate being monitored in the NICU (Source: A shot from publicly available video of neonatal brain research group (<https://youtu.be/aEtpIY8Wiy4?t=119>)). (b) Electrodes placed on a neonate's head to record the EEG. Source: Neonatal brain research group, UCC, Cork

The problem with detecting brain injuries in neonates is that, in most cases the babies do not show any clear physical signs of the undergoing brain damage. In order to find such hidden brain injuries, the electrical activity of the brain is monitored using a method called Electroencephalography. Tiny electrodes (Figure 1b), are attached on the neonate's head to record the brain signals known as Electroencephalogram (EEG). EEG is considered the gold standard for detecting the timing and nature of neonatal brain injuries. Moreover, it also helps in monitoring any progression or improvement in the brain injury after the treatment is initiated.

The normal EEG is a very random signal without any obvious pattern (Figure 2). EEG becomes abnormal when it loses its natural chaotic behaviour and a certain pattern starts to appear.

Clinically, EEG is visually analysed to find any abnormal patterns. Typically, an EEG recording can last for more than 24 hours. The neurologist analyses a 30 seconds window at a time and then proceeds to the next window. Given this scale, a 3 hour EEG recording equates to the length of a football stadium. Furthermore, the expertise to interpret the neonatal EEG is very scarce in busy Neonatal Intensive Care Unit (NICU). Thus, an automated system to detect brain injuries in neonates could significantly help clinical staff in diagnosis and to suggest an early treatment.

Brain injuries in question

This work investigates the automated system for the two most common neonatal brain injuries; Hypoxic Ischemic Encephalopathy (HIE) and seizures. HIE is the primary injury whereas seizure is the secondary injury caused either by HIE or some other brain problem. The reason for working on them at first is that they require the most urgent treatment in the NICU.

HIE is caused due to lack of oxygen (hypoxia) or impaired blood (ischemia) flow to the brain. The long-term outcome depends on the severity of the initial HIE insult. HIE is generally graded into four grades (Figure 2b.1). It can be seen, that the HIE effected EEG exhibits various patterns, some of which may be similar across HIE grades; however it is the inter-pattern variability or the way such patterns occur over the whole EEG recording which characterize its grade.

The treatment involves, cooling the infant to a body temperature of between 32-34°C for 72hours without interruption. However to be effective, it must be commenced within 6 hours of birth. In this narrow window of time the population of neonates who would benefit from treatment must be accurately identified.

Seizures are brief events due to abnormally excessive or synchronous neuronal activity in the brain. On the EEG recording seizures are defined as sudden, repetitive, evolving stereotyped waveforms that have a certain start and ending. Figure 2b.2 shows an example of a seizure pattern. Anti-epileptic drugs are used for the treatment. If seizures are not detected as early as possible then the resulting lack of treatment could cause a severe brain damage or death.

Overview of the automated system for detecting brain injuries

Figure 3 show an overview of the automated system to detect the brain injury in the neonatal EEG. First, the raw EEG is chunked into short segments (epochs) from which

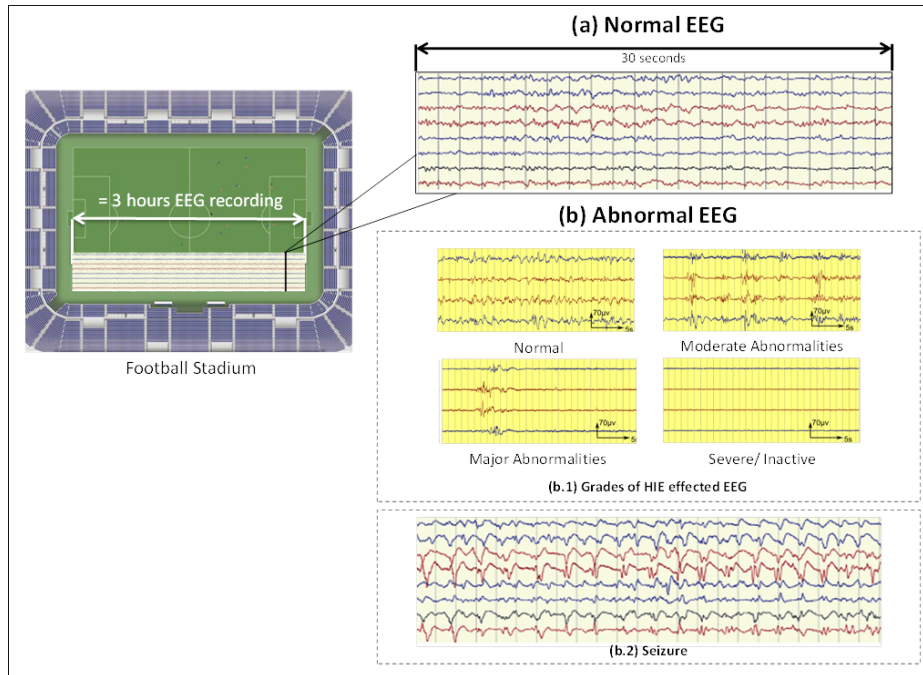

Figure 2: Examples of Normal and Abnormal EEG. Source: Author

different EEG features are extracted. A feature is a measurable attribute of a signal e.g. number of peaks in the analysis window or the mean amplitude of the signal. The features of this segment are then fed to a classifier which decides the class (normal/abnormal) of this epoch. A classifier makes a decision based on the data it is trained on. Figure 3 also highlights an illustration of a simple machine learning classifier. Here working of a support vector machine classifier is presented. During the training process it tries to find a hyper-plane that best separates the data of two classes. In the test/classification phase it calculates the distance from the separating hyper-plane to decide the class of a given test datapoint. The classifier's decision is later converted into a probability of the severity of the brain injury to make it easier for the clinicians to understand the decisions of this system.

Exploring the contextual information to detect seizures

It is well known that there is a lot of information in brain signals if looked over a longer time scale. For example, in the case of seizures, although there is a definite stereotypical pattern of this injury; these patterns evolve in frequency and shape through time. An example of such a seizure is shown in Figure 4. Similarly, for classifying the severity of HIE injury, it is necessary to not only detect the short events like a burst of high frequency activity but also to capture the slow variation of these events in time. Moreover, a clinical expert also analyses the EEG recordings by looking at the bigger picture. S/He goes back and forth through the recording to see what happened before and after a particular event, in order to define its class.

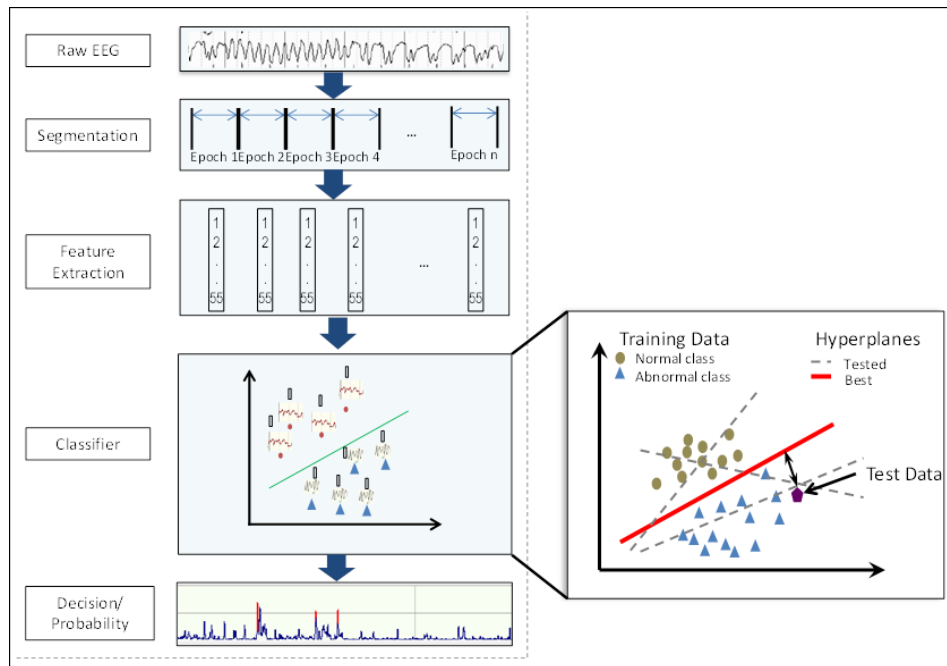

Figure 3: An overview of the automated system for brain injury detection. Source: Author.

A lot of work has been done in the past to develop automated systems for the detection/classification of brain injuries in neonates. However, the classifiers used inside most of these systems, were only able to classify discrete short segments of the EEG. Hence, these systems were either not able to capture the slower time varying changes in brain injuries or they used methods, before or after the classifier, that were not sophisticated enough to use this information to full extent. An example of such system is state of the art neonatal seizure detection system developed by our research group. Features were extracted from 8 seconds epochs of EEG and then classified by a SVM classifier. The contextual information was explored at the decision level by just taking an average of 30 seconds of past and future decisions of the classifier to decide the seizure probability of a given EEG epoch. Nonetheless, this system produced the best performance on the largest available neonatal dataset for seizure detection but its performance was poor in detecting short seizure events because they were being suppressed by this averaging operation.

Similarly, in the case of systems for automated grading of EEG recordings for classifying the HIE injury; the contextual information was explored by extracting features from a longer EEG epoch of 1 minute. It also misclassified many recordings because the features were not able to comprehend all the slower time varying events.

In our current work, a novel automated system is proposed that can look at this subtle but significantly important contextual information at the classifier level. Figure 5 shows an overview of the proposed sequence based classifier. It can be seen that all the modules of the system remain the same, except that another stage is added where features are combined together in sequences and then fed to the classifier. The classifier uses both the information extracted from short EEG epochs and also takes into account the temporal

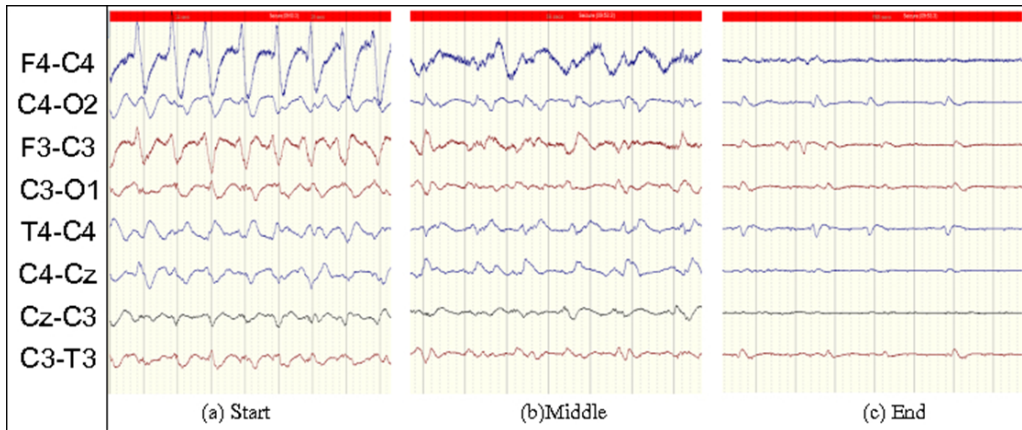

Figure 4: Changes in a seizure pattern in time. Source: Author

evolution of these features in a given sequence. In the example shown in Figure 5, a sequence of 3 epochs is used; however the system is able to cope with any sequence length. Hence we can call it a *dynamic classifier* based system.

The results show promising performance improvements in the detection of seizures. The system has not only helped in increasing the detection rate of both long and short seizures but has also reduced the number of false alarms. A total of 8% increase in detection rate was observed given 1 false alarm per hour.

We employed a similar system for grading the severity of HIE injury in one hour long EEG recordings. The system was able to classify the files into four grades with 87% accuracy. This was a 10% increase from the previous state of the art reported system.

Conclusion and future work

The methods investigated in this work are an important step forward towards the creation of highly intelligent automated systems to detect brain injuries which may help revolutionize neurocritical care in the NICU. Such systems will be able to explore not only the local contextual information of a single neonatal brain injury event but also the bigger global picture where information from other physiological signals e.g. heart rate, blood pressure will also be exploited to produce a score of neonate's overall brain health.

I would like to thank my supervisors, Dr. Gordon Lightbody, Professor Liam Marnane and Dr. Andriy Temko for the support and guidance in writing this article and throughout my PhD journey. Last but not the least, I would like to thank my wife Amna Shafqat who proof read and guided me to write this article for a non-specialist audience.

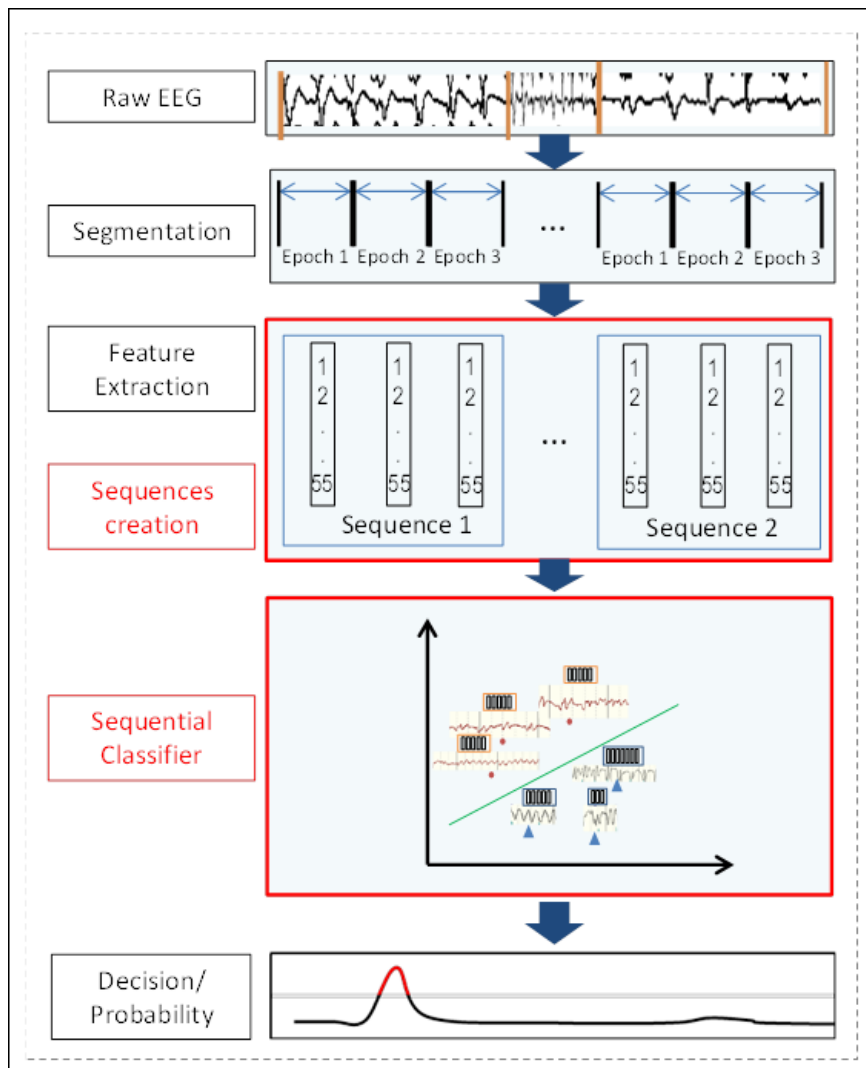

Figure 5: The proposed sequence classification based system. Source: Author

Smarter, faster, better vaccines

Evin Allen

School of Pharmacy, UCC

Vaccines

Since Edward Jenner pioneered modern vaccination in the late 18th century, no other public health intervention has saved as many lives. Vaccines keep us safe and dramatically reduce the mortality and morbidity from many infectious diseases such as measles, diphtheria and influenza. Vaccines are safe, non-viable versions of pathogens (viruses, bacteria) that when administered directs the body into producing an immune response against the pathogen, and it is this that prevents any subsequent infection by the live bacteria or virus.

Vaccine Administration

Vaccines are composed of proteins, unlike most medicines that we are prescribed which are chemical molecules produced synthetically by a series of chemical reactions. Chemical molecules are quite small in size and are very stable to the environment; in contrast proteins are large and complex and very unstable. This means that generally we can't give vaccines as tablets because they would be degraded in the stomach by the same enzymes that break down our food. In addition, we can't administer vaccines as creams or patches because they are too big to pass through the skin unlike small drugs such as nicotine (used for smoking cessation) or voltarol® (used for pain treatment). This results in vaccines being administered as a liquid solution using the often dreaded needle and syringe.

Ultimately, this necessitates a trained healthcare professional i.e. doctor, nurse or pharmacist to administer the vaccine. This adds significant cost to the immunisation process, limits the availability and uptake of vaccines while decreasing the patient experience. In low resource settings, access to well-trained healthcare staff is often low and this can result in erroneous vaccine administration leading to suboptimal patient outcomes. The use of needles and syringes also generates biological waste (contained in the yellow and orange bins in the doctors' surgery). This is expensive to dispose of and can be dangerous if not disposed of due to the risk of cross contamination from potential reuse or accidental stabbing. Thus it is safe to say giving vaccines using a needle and syringe is a last resort for both patients and practitioners!

Vaccine Distribution

The poor stability of vaccines when exposed to extremes of temperature and humidity constrains how we ship and store vaccines. Unlike most tablets and creams, liquid vaccines need to be refrigerated at all points between manufacture and administration. This obligates the use of costly, complex refrigerated distribution and storage systems. It is estimated that this accounts for up to 80% of the cost of immunisation programmes. In remote, low-income areas the infrastructure to maintain this constant refrigerated environment or “cold-chain” is sadly lacking or not fit for purpose. This results in 25-50% of vaccines manufactured annually being wasted due to a break down in the cold chain. This has prompted significant research into developing heat-stable vaccines and is part of the UN Millennium Development Goals and the Bill and Melinda Gates Foundation programme aims.

Microneedle Vaccine Patches

Any solution to the issue of ineffective vaccine delivery should circumvent the distribution and administration barriers outlined; basically vaccines should be easy to use and should be distributable at ambient temperatures. An innovative solution, under development in the UCC School of Pharmacy in collaboration with the Tyndall National Institute, is the use of microscopic projections or microneedles on a flat patch to deliver vaccines through the skin. The difference between our vaccine patch and conventional flat patches are the ultra-sharp yet ultra-small microneedles on the patch surface. Upon application to the skin, these microneedles pierce the tough outer layer of the skin allowing the delivery of the large vaccine molecules deep within the skin. Innovatively, the vaccine itself is contained within the needle structure and dissolves into the skin once the patch is applied. In contrast to a flat patch and similar to a needle, this technology does not rely on skin permeation rather skin penetration ensuring that vaccines are delivered to the body.

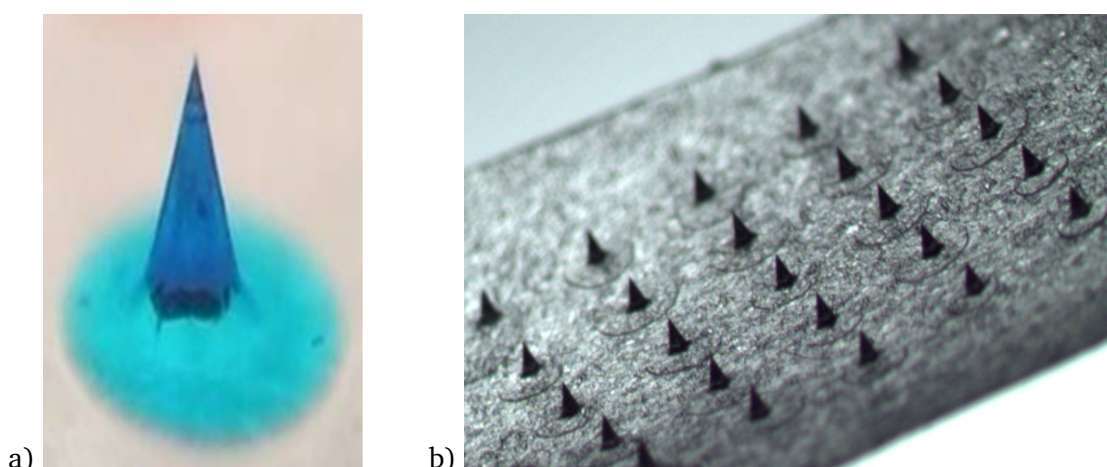

Figure 1: A, 1B: a) An individual microneedle 0.5cm in height. b) Typical microneedle vaccine patch 1cm² in size. Source: Author.

Source: Author
Microneedles are usually half a centimetre or less in height (figure 1) and do not penetrate deep enough within the skin to activate our pain receptors or damage blood vessels within the skin. This minimally invasive method of vaccine delivery avoids the pain often associated with traditional vaccination. Microneedle mediated vaccine delivery also removes patients fears of needles that may be preventing them getting vaccinated. Due to their simple design, microneedles patches can be self-administered by patients and overcomes the need for trained professionals. Microneedles are a solid dosage form and therefore should demonstrate enhanced heat stability compared to liquid solutions. This assumption is based on the fact that protein solutions such as milk rapidly go off if not refrigerated but can be stored for much longer periods of time if dried to a solid form such a milk powder.

Influenza Vaccine Microneedle Patch

My research focuses on the development of an influenza vaccine microneedle patch to allow for immunisation against seasonal ‘flu. The hypothesis was that we could successfully reformulate a licensed commercial seasonal flu vaccine into a microneedle vaccine patch that would be amenable to self-administration and ambient shipping conditions.

Vaccine reformulation

So it’s easy to take a liquid vaccine and make it into a microneedle patch, right? Not really, making medicines that are safe, stable and efficacious is an extremely challenging area known as formulation science. Some substances dislike water; others dislike acidic or basic solutions and require a certain a pH to work whereas some can interact with inert materials within the “formulation” causing them to lose their function. Every medicine that we take is a complex recipe that contain various different ingredients, some are added for flavour (for example, in children’s medicines), some to preserve the medicine, some to stabilise the drug or vaccine that we are delivering. In addition, all the materials that we use in our formulation need to be certified as safe. Thus as formulation scientists we are like chefs with a very small number of ingredients expected to make the same high quality dish without losing any of the taste. The first part of my project was to develop a “secret sauce” that would be compatible with and stabilise the vaccine but would form needles that would be strong enough to pierce the skin.

This series of limitations lead me to develop a formulation based on the sugar trehalose. Trehalose is a naturally occurring safe, sugar substance, very similar to glucose (the main ingredient in the drink Lucozade), which is used by many plants and insects to survive. When these plants or animals are dehydrated, trehalose takes the place of the water molecules that have been lost and secure the physical integrity of the animal or plant. Upon rehydration, trehalose is replaced by water allowing for normal biological function

to resume. Similarly, when we dry vaccine solutions, trehalose takes the place of water ensuring that the vaccine proteins aren't destroyed.

As vaccines are quite sensitive to heat and other physical stresses, we have to use low temperatures and gentle processes to manufacture microneedle patches. To make a bun you add your mixture to the baking tray where it takes the shape of the tray forming a lovely bun. In our kitchen we use a specialised baking tray or mold, designed and fabricated by engineers in Tyndall using a state of the art, high precision patented process. These molds produce ultra-sharp microneedles which are able to penetrate skin easier than other microneedle designs because the application pressure is focussed on a very small area (like a nail or a stiletto). I borrow a technique from cooking whereby a modified pressure cooker is used to dry the vaccine after is dispensed to the mold, so that we can dry the vaccine at room temperature rather than at high temperature. Having tested the integrity of the vaccine pre and post fabrication I found that this process had no effect on the vaccine. This is a vital step in proving to regulators that microneedles are a safe and effective alternative to liquid vaccines.

Do Microneedles work?

Do microneedles work? This is a fundamental question that has kept me up all night thinking about science over the last three years. Do microneedles penetrate the tough skin that protects us from external insults? Is skin the right place to delivery vaccines to, considering we normally inject vaccine into the muscle? To answer these questions, I've performed an extensive number of tests in mice and pigs as well as lab based tests. We use animal tests to provide information that *in vitro* tests will never supply, mice are chosen as they are easy to handle and have a long track record of use in early stage vaccine research.

Initially I tested the effectiveness of microneedle vaccines in mice by administering equal amounts of vaccines using our vaccine patch and by the traditional needle and syringe. The results were staggering, it was observed that a much higher response was observed in mice immunised using the vaccine patch. Subsequently, mice were immunised intramuscularly with needle and syringe with higher doses of vaccine and it was found that eight times the dose administered via our patch system was required to get equal responses. I also examined different formulations to determine the best secret sauce, by adding various plastic polymers and sugars such as polyvinyl alcohol, sucrose (i.e. table sugar) etc. to the formulation and found that polymers while making microneedles mechanically stronger delay how quickly vaccines are dissolved. From a patient perspective this is really undesirable as we want vaccines to be delivered quickly as this will mean patients wearing patches for shorter times. This minimises the risk of poor outcomes from patches falling off or being removed too quickly, as nobody likes wearing patches or plasters for a period of time.

These results demonstrate the enormous potential that microneedle vaccines have as well

as the attractiveness of skin for vaccine delivery. Skin is the largest organ of the body and has a rich immune system of its own. It is this high quality immune system that drives the enhanced vaccine response we see compared to intramuscular needle based delivery. In practice, we only rarely observe the use of vaccine delivery to the skin (intradermally) for the BCG (Tuberculosis) vaccine, due to the extremely challenging aspect of delivering vaccines intradermally.

Microneedle vaccines: Universal vaccines

Every year, the circulating flu viruses changes slightly (a phenomenon known as drift) and in rare cases they dramatically change (shift), this dramatic change often results in an influenza pandemic like the swine flu outbreak. This constant viral evolution necessitates the development of a new vaccine every year. Wouldn't it be great if we had a universal flu vaccine that would protect against all strains of flu? Scientists have been intensely working on this Holy Grail for years with little success. In collaboration with a virology group based in the UK, we studied the responses induced by microneedle vaccination against a diverse group of flu strains. Intriguingly, we found that the responses in mice using vaccine patches neutralised vastly different influenza viruses unrelated to the strain within the vaccine. This is a very novel and promising finding and suggests that delivering vaccines via an alternative route such as the skin results in a much broader, better response.

Vaccine Stability

The major driver for a change in how we deliver vaccines is the need for thermostabilisation. I studied the stability of vaccines at accelerated storage conditions i.e. 40°C and 75% relative humidity. Vaccines formulated in our microneedle patch system were found to be very stable and did not lose any activity over a 12 month period; in contrast liquid vaccine began to degrade after 10 days. As microneedles rely on their unique design to be effective *in vivo*, we also examined the immune response when microneedles on stability study were used to immunise mice. Excitingly, no decrease in immune response was observed compared to patches that had not been exposed to these extremes of conditions.

What does all this mean?

As a PhD student, one becomes very philosophical over time and begins to ask profound questions such as what does all this mean? Does it mean anything? Have I added anything to existing knowledge? Thankfully these results do mean something in this field. The fact that we get equivalent responses with lower vaccine doses when using a microneedle patch means that we can immunise greater numbers of people with the same amount of starting material. By generating a broad immune response, we have a vaccine that could protect against viruses different to that contained in the vaccine itself. We also have developed a vaccine delivery system that harnesses the rich and underexploited immune system within

our skin. Most importantly we have a vaccine patch that is highly stable to extremes of temperature and humidity allowing for ambient shipping. It means that one day you will be able to get vaccines delivered in the post that you can self-administer without the need for a healthcare professional.

The future of Microneedles

Microneedle mediated drug and vaccine delivery has become an area of rapid interest with many pharmaceutical and biotech companies collaborating with university research groups or developing their own research units. The commercial success of microneedles vaccines is dependent on significant investment into clinical trials and manufacturing facilities. Clinical trials will initially aim to demonstrate the safety of vaccine patches in small numbers of patients. This will be followed by larger trials that will recruit thousands of patients to show how well microneedles will work compared to traditional liquid vaccines. Existing vaccines are relatively low cost pharmaceutical products compared to some of the new oncology or hepatitis medicines being marketed. This means that vaccine patches will need to be manufactured at equal or lower prices for companies to change the way they make vaccines. It is healthcare systems, patients and providers such as the HSE or WHO that incurs the cost for vaccine distribution and administration, so manufacturers need to be incentivised to bring this technology to market. To do this, innovative technologies will need to be harnessed to ensure that we can bring this disruptive vaccine delivery product to market. This issue has been significantly researched as part of my research, with the development of a system that uses existing inkjet printing technology.

This project demonstrates the tangible effect that university based research can have on healthcare and patient outcomes. Any death is sad, but vaccine preventable deaths are beyond sad; they are inexcusable and unforgivable. Hopefully in the near future, these smarter, faster, better microneedle vaccines will end this tragedy.

Thanks to my supervisor Dr Abina Crean and co-supervisor Dr Anne Moore and Tyndall collaborator Dr Conor O'Mahony. In particular, I would like to acknowledge the microneedles research group in the School of Pharmacy and the technical staff for their on-going support. I would also like to acknowledge the School of Pharmacy and COMH for my PhD funding.

I see what is said: The interaction between multimodal metaphors and intertextuality in cartoons

Wejdan M. Alsadi

School of Languages, Literatures and Cultures, Applied Linguistics Programme, UCC

“Language has to be realized through, and comes in the company of, other semiotic modes” (Gunther Kress and Theo Van Leeuwen, 1998, p. 186)

A new path for linguists

Printed material, such as advertisements, manuals, instruction books, maps, graphics, and cartoons usually depend on the interaction between verbal and pictorial/visual modes to convey messages and information. The interaction of those different semiotic modes to make meaning is described as multimodality, and hence a multimodal theory of communication has been established. While the emphasis on the verbal-visual interaction is not new, its contribution to the field of linguistics has been recently developed. A linguist whose concern has for a long time been on verbal language, either written or spoken, is now better able to analyse the language of advertisements, the meaning of which is also communicated through visual features; and examine a news text accompanied by an image or a photograph. However, Jewitt (2009) provided a definition of multimodality that focused on the role of different semiotic modes (verbal, visual, and audio/visual) in achieving meaningful communication:

Multimodality describes approaches that understand communication and representation to be more than about language, and which attend to the full range of communicational forms people use — image, gesture, gaze, posture and so on — and the relationships between them).

The following is a good example where visual and verbal elements form part of the cartoon’s meaning:

In the below cartoon, a couple is depicted as offering a gift for each other while saying the same expression. However, the material value of this same expression ‘All this 4 u’ differs in terms of the associated visual choices. It is important to consider the meaning of the predeterminer ‘All’, *the whole of something*, to grasp the intended meaning of the cartoon. The man’s offer which is represented visually as ‘a small tree’ does not match the presumed meaning of ‘All’ in his utterance if it is compared to ‘the Earth’ in his right hand. Moreover, the choice of the tree to represent the man’s offer stands for the proportion of



Figure 1: Source: Hana Hajjar

his sacrifice which is very little in comparison to the woman's sacrifice 'the Earth'. In other words, the wife has approached the real meaning of 'All' by sacrificing the whole whilst the man failed to approach that meaning. The verbal-visual interaction guides readers to come up with contrasts such as, man's sacrifice vs. woman's sacrifice, or man's giving vs. woman's giving.

Multimodal metaphor

The multimodal theory has inspired other scholars to introduce new terms describing phenomena manifested in our daily life. In texts, such as advertisements and billboards, metaphor may appear not only visually, but also multimodally, that is, a combination of both the pictorial/visual and the verbal mode. Metaphors generally consist of two major elements: the target and the source. The target or abstract concept is understood in terms of the source which is often a concrete object or element. In verbal or visual metaphors the target and the source are represented either only verbally or only visually while in multimodal metaphors the target and the source are exclusively and predominantly represented in two different modes: the visual and the verbal mode.

Like advertisements, cartoons are rich in metaphors through which cartoonists can explain complicated political situations, or sum up and comment on current events and social issues in a particularly humorous manner. Cartoons are a good data source to explore multimodal metaphors since cartoons often rely on visual and verbal modes and metaphor is a common technique frequently used by cartoonists.

The funny side

As we have talked about multimodal metaphors in cartoons, we should bear in mind the humour aspect which is often the ultimate purpose of many cartoonists. Combining both the pictorial and verbal modes, cartoons may be more appealing and even more attractive in conveying the cartoonists' humorous message. However, there is scholarly agreement

that humour appreciation depends on the broader socio-cultural context in which cartoons appear: what seems to be funny and humorous to one person might be viewed as unfunny, or even offensive to another person.

The study

For my PhD project I have collected 202 cartoons from three English-language Saudi newspapers: *Arab News*, *Saudi Gazette*, and *Al Riyadh*, and perform a qualitative multimodal analysis of the cartoons. I have thematically classified the cartoons into four major categories: *gender*, *social phenomena*, *education and the impact of technology*, and *economy and prices*. The analysis aims to show how visual and verbal elements and choices interact to make humorous meaning, and how themes can affect the cartoonists' choice of a particular technique in multimodal texts such as cartoons.

For example, the cartoons related to *economy and prices* have shown a notable use of multimodal metaphors to depict the rise in prices, the cost of living, loan traps, and the stock market. In 28 out of 39 cartoons related to this category, multimodal metaphors were employed creatively. The creativity of those metaphors not only relies on being totally innovative, but also on the cartoonists' ability to exploit the existing idiomatic or metaphorical expressions used in daily communication (such as figurative expressions and phrasal verbs). Those expressions are visualised in a particularly humorous manner and are accompanied with verbal clues and labels to help readers or viewers recognise the reference to a certain popular expression, or 'intertextuality'.

Intertextuality in cartoons refers to the cartoonist's borrowing or quoting from previously existing texts, and to the viewers' interpreting of the cartoons in the light of those texts. Here are some examples to show how our daily speech and expressions may act as an inspiring source for cartoonists to create humorous multimodal metaphors.

Creating Multimodal Metaphor

Bills absorb ones blood

In the below cartoon, the word 'Bills' is significant in identifying the target of the metaphor in the cartoon. It is a multimodal metaphor because the source of the metaphor 'the mosquito and the blood being absorbed' is represented visually while the target of the metaphor 'Bills' is represented verbally. The word 'Bills' implies the money needed to pay bills. Accordingly, the multimodal metaphor can be verbalised as: **BILLS CONSUMING ONE'S MONEY IS LIKE A MOSQUITO ABSORBING ONE'S BLOOD**. Humorously, the shared victim in both cases is the man.

A reader who is familiar with everyday speech in the Saudi society would have no difficulty accessing the daily metaphoric expression used by the society members to complain about



Figure 2: Cartoon 1: Source — Rabea published in *Al-Riyadh*

the high bills paid for services: **bills absorb one's blood**. The cartoonist relied on the metaphoric expression and his imagination to design the above image. He inserted one essential verbal element 'bills' and another essential visual element 'blood' as a means to help familiar readers recall the original expression.

Drowning in loans

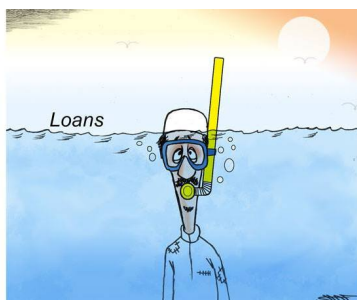

Figure 3: Cartoon 2: Source — Al-Shafea published in *Saudi Gazette*

The above cartoon depicts a man in the middle of the sea putting on a snorkeling apparatus for breathing. He is not dressed in swimming clothes, but in his torn thobe as a symbol of his financial problems. The word 'loans' is written above the seawater. The cartoon includes a multimodal metaphor as the source 'sea' is represented visually while the target 'loans' are represented verbally. Again, the man is the victim in both situations: in case of the sea and in case of the loans. The basic metaphor LOANS ARE LIKE A DEEP SEA may also suggest a metaphorical scene based on the image and the associated word: HAVING LOANS IS LIKE DROWNING IN THE SEA.

However, the imaginary scene of 'the man under the water' accompanied with the word 'loans' evokes the Arabic idiomatic expression 'to be drowning in debts/loans' which is used to describe someone involved in debts and bank loans. In other words, the cartoonist exploited the literal meaning of the word 'drowning' to create the metaphorical scene while referring to the idiomatic expression through giving the verbal clue 'loans'. The expression has an English equivalent 'drown in something' which means 'to have more of something than you are able to deal with'. A typical example is 'I'm drowning in unpaid bills' (Cambridge Online Dictionary).

Big fish eats small fish

The below cartoon shows a hierarchical order of eight colourful fish: the big ones eat the little ones. It is a typical scene of marine life where the weak creatures fall victims to large creatures. The words written on the four fish are economic terms in the world of trading. Those economic terms are represented in a hierarchical order corresponding to the size of the fish. The cartoon includes multimodal metaphor since the source ‘big and small fish’ is depicted visually while the target is represented verbally through the words ‘supplier’, ‘wholesaler’, ‘retailer’, and ‘consumer’. THE SUPPLIER, THE WHOLESALER, THE RETAILER, AND THE CONSUMER ARE LIKE FISH IN THE SEA WHERE BIG ONES EAT LITTLE ONES.

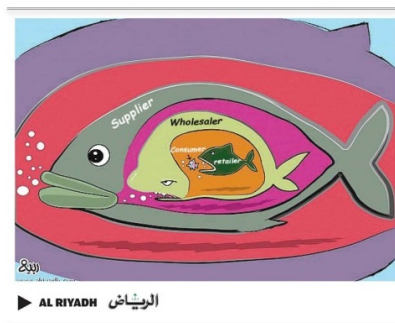

Figure 4: Cartoon 3: Source - Rabea published in *Al Riyadh*

The hierarchical order suggests that the supplier gains profits from the wholesaler who gains profits from the retailer who finally gains profits from the consumer. The consumer is the victim and the weakest of the four who gets no benefits, but pays heaps of money instead. Without the words, we would neither know the metaphor, nor understand the intended meaning of the cartoon. However, the metaphor is based on a common metaphorical expression ‘BIG FISH EATS SMALL FISH’ used in daily communication to describe the world of trading and stock market as well.

Prices are like fire



Figure 5: Cartoon 4: Source — Khaled republished in *Saudi Gazette*

The cartoon displays a scene in which some green notes are depicted as a moving creature jumping into flames of fire. As the flames of fire are identified as ‘Ramadan prices’, the

green notes stand for money. However, the cartoon includes a multimodal metaphor as the source 'fire' is depicted visually whereas the target 'Ramadan prices' is represented verbally. The metaphor can be verbalised as RAMADAN PRICES ARE LIKE FIRE. It suggests that the high prices during Ramadan consume money in the same way as fire burns objects. The month of Ramadan is a profitable season for merchants. During that month, prices reach their peak. Generally speaking, familiar readers can easily recall the very common metaphoric expression PRICES ARE FIRE which is used in daily life to describe the rise in prices. While the cartoon is based on a conventional verbal metaphor, we cannot overlook the cartoonist's ability to make it humorous by adding imaginary visual elements, such as 'depicting money as a flying creature jumping into the flaming fire'.

Multimodal metaphors between reality and imagination

Whenever I come across a cartoon that evokes a particular expression in my memory bank, I can feel the power of our daily communication. Our everyday language can either affect our language production as in the case of cartoonists relying on their linguistic repertoire to create multimodal metaphors, or influence our reception as in the case of readers who interpret those metaphors in the light of already existing texts. Such a conclusion draws on Bakhtin's and Kristeva's theory about intertextuality: authors do not completely depend on their own minds to create their texts, but rather build them from already existing texts. So, texts cannot be separated from the social and cultural textuality out of which they were born.

While cartoonists rely on the available metaphorical/idiomatic expressions in creating their cartoons, their imagination is a major ingredient in making the cartoon appealing and creative. They use their imagination to add balanced visual and verbal elements to end up creating a multimodal metaphor that might also be appealing to readers who are not familiar with the original expression. However, readers who share a similar social and cultural background often rely on the verbal clues associated with the image not only to laugh at the funny metaphors, but also to enjoy sharing the same source of inspiration with the cartoonist.

Conclusion

On a larger scale, my study falls into two research areas: multimodal research and humour research. It contributes to the growing literature on multimodality in the field of Applied Linguistics. It not only provides insights into how visual and verbal modes interact to make meaning, but also shows how those semiotic modes cannot be isolated from the broader social and cultural context of a particular society. What is more interesting about the above examples is that familiar readers can 'see what is said': readers are invited to a kind of visual-verbal communication in which they are unconsciously involved in a process

of searching their linguistic repertoire or memory to recall the expression that match the available visual and verbal elements in a cartoon. The study moreover contributes to the body of literature on humour research, particularly in the Middle East since the cartoons are collected from Saudi online newspapers. While we can talk about humour studies in the Arab world, contribution to humour research in the Arabic, particularly the Saudi, context is still urgent.

My thanks to my superb supervisor Dr. Martin Howard for his continuous support, encouragement, and academic guidance.

Introducing mobile cloud technology into m-health to deliver better care/support in case of emergencies

Hazzaa Naif Alshareef

Department of Computer Science, UCC

Introduction

Recent years have seen an increase in the use of mobile devices such as smartphones, tablets, and smart-bands in people's lives. Features offered by these types of devices, such as ease of use and being wireless enabled, allow people to access services that can improve their quality of life. One of the most important aspects of life that can be accessed through mobile devices is health services, whereby users have the ability to track their health status 'on the move', such as by tracking physical activities (e.g., walking and running) and monitoring body status (e.g., heartbeats rate). On the other side, medical professionals and centres can use mobile devices to provide better healthcare services to the public, as doctors, for example, can access patients' records and laboratory results on the move instead of looking at printed charts or files. This reduces the time needed to deliver healthcare to patients. Furthermore, users can communicate with medical professionals in cases of emergency to discuss a medical problem, which could relieve pressure on emergency departments. These practices are known in the health sector as m-health.

However, mobile devices have restricted computational and storage capacity, as well as running on batteries that have limited power. These limitations render mobile devices unable to run the demanding tasks that may be required for accessing health services. Therefore, a solution is needed to allow users to utilize their preferred devices, such as smartphones and tablets, to access or deliver health services with complex and highly computationally heavy tasks being executed, not solely on mobile devices but also on other devices and in different places.

The most suitable solution is to shift heavy computational tasks to remote devices that offer better performance and then return the results to mobile devices without the latter having to do the processing. This is exactly what happens in cloud computing: a health service or application is hosted in the cloud, and mobile devices use this service remotely over the Internet without needing to be concerned about how the service is executed and what resources are needed to get the result. All the user needs to do is request the service and wait for the result.

Introducing cloud computing technology together with mobile computing technology into the health sector is not a straightforward solution, however, because the integration of these two technologies, known as mobile cloud computing technology, has specific limitations, such as disconnection issues and concerns over privacy and security.

In my research, I examine these kinds of limitations and discuss the possibility of introducing mobile cloud computing technology into the health sector, with the aim of providing a robust, trustworthy system that can deliver healthcare services to mobile users in emergency situations in an easy and reliable way.

Terminology

M-health

M-health is an abbreviation of ‘mobile health’, which means to provide/deliver healthcare services on mobile devices such as smartphones, tablets and wearable devices to minimize shortcomings in the traditional medical framework in an efficient way. Examples of m-health services could be creating electronic medical records (EMR) and making them accessible by mobile devices, establishing a communication link (i.e., video session) between a patient who is facing a medical issue and a doctor who can provide health support to that patient, or retrieving useful information in the case of an emergency, such as the shortest route to the nearest medical centre.

M-health has gained increased attention from researchers in both the medical and information technology (IT) fields for the purpose of reducing the pressure on hospitals, as well as cutting the cost of health services to make them available to everyone. In practice, cloud-based services, featuring both cloud computing and mobile cloud computing technologies, have provided an m-health framework.

Cloud computing (CC)

Cloud computing (CC) is a new technology that is usually founded on data centres with high levels of computing and storage capacity. CC is now widely used in the computer world because of its desirable features, such as pay-as-you-use schemes, low cost, and great flexibility in implementation. CC has attracted both new developers and the owners of existing systems and, furthermore, represents a new direction and the next generation of the IT industry.

Mobile cloud computing (MCC)

Mobile cloud computing (MCC) technology is considered a potential solution to deal with mobile device shortcomings, such as the possibility of disconnection and a short battery life. The main differences between this technology and CC technology are that MCC enhances mobility and offers the possibility of building clouds from mobile devices for data storage and computing. MCC also provides functionality for managing data and services

in a distributed manner that supports several platforms, systems and applications. In the computer field, the term 'MCC' has two definitions. Firstly, a cloud of mobile devices, which means that mobile device resources (storage and computing) are brought together to bring advantages such as access to multimedia and sensor data without the need for large data transfers across computer networks, efficient access to stored data on other devices, and the spread of ownership and maintenance of hardware. Secondly, shifting storage and computing processes from the mobile device space to the CC space, leads to solving mobile device limitations by, for example, saving battery life. The latter definition is widely used in the Information and communications technology (ICT) field and I also consider it in my m-health research project.

Motivating scenarios

Two different scenarios are presented here that would benefit from a system that can provide health services to the public in emergency situations with the help of MCC technology.

Crowded places

When a large number of people are present in the same place to perform the same activity, such as watching a football match or attending a concert or religious event, there is a high chance that emergency medical situations will occur. For example, in my research, I consider Al-Haj (pilgrimage to Mecca) as such an event, where hundreds of thousands of people are present in the same area, for a certain/limited period of time, performing virtually the same actions. Some issues are related to the medical history of the pilgrims and others can occur because of the environment and the location of this event. Imagine that a person who has a medical history of, for example, heart disease requires healthcare urgently. Owing to the nature of the crowd, reaching such a person with regular emergency services would be difficult or, in some cases, might even be impossible.

However, a doctor or nurse might be located in the crowd, not far from the person in need of help and can, therefore, immediately be available. Alternatively, the person in need could use a mobile device to obtain directions to the nearest medical centre or retrieve useful information that could be vital. Therefore, a system able to link users who are looking for care with those who are able to provide that kind of care is potentially life-saving.

Residential areas

Emergency situations can also occur in the home, from cases of people falling downstairs to serious fires that destroy a whole house. Assume now that such an emergency situation has been detected in a home using a modern home-monitoring device. Generally, this will trigger an alert to one of the emergency departments, such as the ambulance and/or fire fighting services.

Therefore, a multi-notification system is needed: one that automatically searches for doctors or nurses in the vicinity of an emergency situation whilst also providing useful information such as the shortest route to the location. This notification and triggering of an alert at the relevant emergency centre would happen simultaneously.

My research

As mentioned above, mobile devices allow people to have access to the Internet on the move and mobile cloud computing allows the deployment of services that are accessible over the Internet by mobile users. Therefore, introducing these technologies would improve healthcare applications and benefit a variety of users (including patients and healthcare providers).

The research aims to enhance the delivery of healthcare information (or advice) and expand the point-of-care concept to everybody, anywhere, when they are in distress. This means mobilizing care for people in emergency situations wherever these occur, as well as notifying health providers and establishing communication links (if needed) between all the parties concerned for delivering health services.

Thus, the research focuses on the design and implementation of a mobile cloud healthcare system that delivers at the point of care in order to provide a robust and reliable mobile health system that can deliver fast and low-cost care to the public when experiencing health emergencies. Figure 1 shows an overview of the system model.

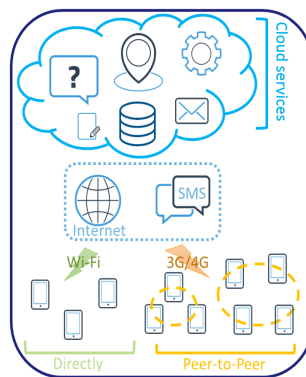

Figure 1: System Model Overview. Source: Author

To achieve this goal, I am working on two main areas: infrastructure and services. In the first area, I enhance the connectivity aspects of the system by allowing mobile users to create/join self-organized peer-to-peer networks. This kind of network is then managed/monitored by the cloud and offers its users the ability to connect to the cloud to seek care, either directly or via a neighbour who has a better connection to the cloud. It also allows the members of such a network to share resources or data locally without the need to use a carrier/caller network (3G/4G) with its associated costs.

Similarly, the cloud can reach users directly or via a neighbouring link. This method will increase the system availability, as well as reducing or minimizing the risk of disconnection, which is one of the shortcomings of deploying mobile cloud computing technology.

Moving to the second area, which is creating services that are hosted in the cloud and can be accessed by mobile users, these services can operate together to deliver better healthcare services to users whenever they are needed. Location, medical state, and the connectivity status of users are tracked by the cloud for the purpose of providing the best possible outcomes.

An example of such a service could be sending a request to the cloud to retrieve medical advice that could help in delivering a healthcare service to a user who is facing an emergency situation on the motorway. Another service could be to allow users to find doctors or nurses who might only be a few steps away from them in order to discuss a medical concern. A service could also link a monitoring device (such as a body sensor) whereby if an emergency case is detected a request for help would be sent automatically without the need to involve the user in the operation.

However, designing and implementing such a system will generate a number of challenges. These challenges can be divided into three main groups, which are presented below.

Challenges related to technologies in use: As stated previously, cloud computing technology was introduced to offer better outcomes (such as high performance and high availability). As is known, cloud computing still suffers from some shortcomings, such as issues related to security, privacy, reliability, and availability. In my proposed system, security and privacy are the most important issues because the technology is required to deal with people's medical data, which are very sensitive and have to be protected and secured. Therefore, the system has to provide a strong security mechanism that ensures that the content of medical data is stored securely in the cloud using high-level protection strategies, such as data encryption. The system also needs to ensure that both cloud services and stored data can be accessed by the right people to minimize the possibility of attack. This requires ensuring access to the system using a high-level authentication technique, such as a one-time-password or SMS-authentication scheme or one of the biometric authentication methods that offer a high degree of protection.

Challenges related to users who participate in the system: In addition to users who are seeking health services and want to ensure their sensitive medical data are protected and secured, there is another kind of user: those who provide health services to the public and have specific requirements to help them deliver care or support to people in emergency situations. These requirements include ease of use, fast response, and high availability. It is also understood that providing health support to the public in an out-of-hospital way will put more pressure on healthcare professionals. Using the concept of volunteering is a key solution to this issue, whereby a medical

professional, or anyone who is qualified, authorized and able to deliver healthcare to the public, has the choice of participating or not. The system also has to allow them to change their status if required; for example, from “available” to “offline” or to “dealing with a case”. Finally, the system has to have a form of management that ensures all participating users are treated equally in the case of redirecting medical requests. Carrying out a survey to discover medical professionals’ views of using such a system could be useful to my research.

Challenges related to the collected data: To provide a healthcare service to someone, some data have to be collected, such as current location, medical history (including body monitoring data, e.g., heart rate and blood pressure), and personal information (e.g., name and age). This raises ethical issues regarding how this type of information will be used and who will access the data. Collecting this type of information is critical for the proposed system to provide proper help to that person. For example, the system has to be aware of any allergies or special medical requirements (e.g., heart-related issues or asthma) before redirecting the case to an available medical professional. Another example is related to tracking technology, as the system has to identify the current location of the person seeking help in order to connect him/her to medical staff who are in the vicinity. Furthermore, the system has to track medical professionals for the purpose of redirecting medical emergency cases that are close to their location. Therefore, collecting this type of data is very important and might be life-saving. However, the system has to provide a high level of confidence to users that their data will be used only for medical purposes and they have the right to accept or reject sharing this type of information with other medical parties, such as hospitals or insurance companies.

With regard to the design process, the first step was to define the research problems and then review similar projects and related research. Then, I formulated hypotheses to start the system design, during which stage I designed my system taking into account its suitability for implementation in real-world scenarios. Now, I am testing the design in a real environment to check the viability of the system. I am also analysing the results collected during the previous step to make recommendations that should help in dealing with the problems that were defined in the first step. I may go from this step to the design stage for the purpose of making any modifications that are required to obtain clearer results or correct any issues in the design part. Figure 2 shows the design process.

To summarize, I hope that future healthcare systems can benefit of my research in enabling the delivery of better care to the public as well as reducing pressure on medical centres.

Hazzaa N. Alshareef is a PhD student in the Mobile and Internet Systems Laboratory (MISL) in the Department of Computer Science at University College Cork (UCC) under the kind supervision of Dr Dan Grigoras. His research is funded by the Saudi Electronic University in

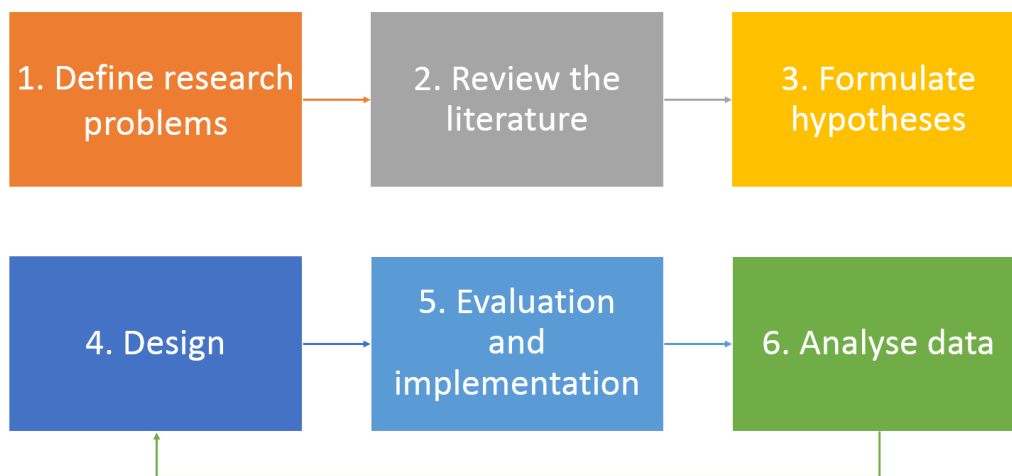

Figure 2: Design progress chart. Source: Author

Saudi Arabia. He is forever indebted to his supervisor, Dan Grigoras, his MISL colleagues and his family, Norah, Naif and Najat, for their help and support during his journey.

Tired of slow internet? Lasers to the rescue

Joveria Baig

Department of Electrical and Electronics Engineering , UCC

Before you marry a person you should first make them use a computer with slow Internet to see who they really are. (Will Ferrell)

Why do we need faster internet?

The Internet has made long distances almost transparent, allowing people living in different parts of the planet to communicate in an instant. With the advent of internet in developing countries, researchers all over the world have been able to collaborate to find cures for deadly diseases prevailing in most developing nations. The average number of internet users increased from 16 million users in 1995 to 3079 million users at the end of the year 2014 and is anticipated to grow exponentially over the next decade. This increased dependence on technology also results in an increased need for faster internet.

Let's illustrate this with an example. Imagine you are a surgeon in Southern Africa and you are about to operate on a child having a potentially fatal disease. It is critical to perform the surgery at the earliest opportunity. However, there are complications involved, therefore, you decide to consult a senior surgeon living in another part of the world who has dealt with many such complications before. You turn on the video conference software to start your conversation. Unfortunately, everyone else in your building is using the internet at the same time for their ongoing research. A few seconds into your all-important video call, the video begins to deteriorate, as illustrated in Figure 1, and eventually completely vanishes. You have just suffered from a slow internet connection. Before trying to find a solution to this problem, let's first understand how the internet works.

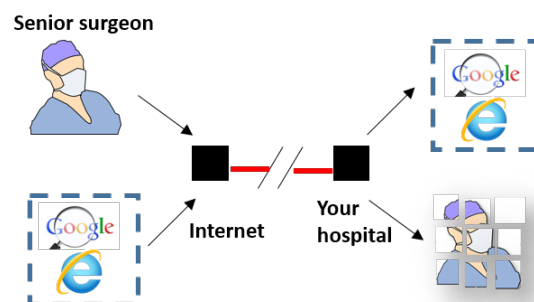

Figure 1: Simplified layout of internet framework illustrating deterioration of senior surgeon's video quality due to slow internet connectivity. Source: Joveria Baig

How does the internet work?

During childhood, you might have made a telephone using two match boxes or baked bean cans and a span of thread. The internet nowadays is a highly advanced ultra-modern version of this telephone. There are various ways in which information travels from one end to the other. Many years ago, a wire cable was used such as in landline phones to send your voice from home to the nearest telephone exchange. With upcoming technology, it was then possible to send information in air without the need for wires, such as in cellular phones. Another mode of very fast and effective communication which has revolutionized the internet industry is the use of light to send information down a transparent pipe, known as a fiber optic cable, from one end of the globe to another. An optic fiber is a strand of glass with an exceptionally small diameter, up to ten times thinner than the human hair, which is capable of transporting up to millions of telephone calls every second. The secret to the success of optic fibers is light, which travels in these fibers at very high speeds. When you switch on a bulb in your room, you do not see light rays travelling down from the bulb to the floor; it happens so quickly that your nervous system is too slow to even register it. To give it a perspective, it takes only 1.3 seconds for light from the moon to reach the Earth! This property of light makes it an excellent carrier for data in data transmission over long distances.

So, the modern internet works like this: you send a video from your computer to a friend living in another part of the world, your computer releases electrical signals which go directly to a light source. Accordingly, a special sequence of light pulses corresponding to the video is produced and sent down an optic fiber. At the receiving end, these light pulses are converted back into electrical signals and the video you sent is decoded on your friend's computer, ready to be opened.

The choice of the light source is very important for these fibers. Due to high directionality, lasers act as excellent light sources for optic fibers primarily because they enter and leave a long distance optic fiber with minimal losses in the energy it carries. So, even with such powerful light sources, why is the internet still slow? Let's consider a simple analogy.

Imagine yourself in a situation where you are given a daunting task of transferring a million bricks from one part of the world to another within an hour. You decide to hire a red power ranger to transport these bricks for you. However, a red power ranger with his entire super powers combined needs at least a day to transport all these bricks on his own. Similar to the power ranger, laser is the super hero in the real world that is used to transport internet data (analogous to bricks) in optic fibers. But even with such great strengths, a single red colored laser (analogous to a red power ranger) has its limitations and cannot transfer so much data all at once which makes this data transfer slower than what is required. To solve this problem, internet has evolved and now uses many different colored lasers to send information along the same optic fiber. This is very similar to the red power ranger getting help from his entire team consisting of blue, yellow and green power

rangers to transfer the bricks at a much greater speed. In summary, one colored laser, like one power ranger, carries less data in a given time. More colors of lasers together, like many power rangers, carry more data. Returning to the scenario in Figure 1, if, instead of a single wavelength laser, multiple different wavelengths were used, you would not face the problem of deteriorated video quality. This is because in this case you have a set of colored lasers (bandwidth) assigned to you that you do not share with your colleagues. Therefore, the data sent by your colleague does not affect your internet speed significantly. This is illustrated in Figure 2 which shows the internet signal flow from your hospital to the senior surgeon in the other part of the world. This idea of using multi-colored lasers is one of the main reasons why internet is much faster today than it was ten years ago.

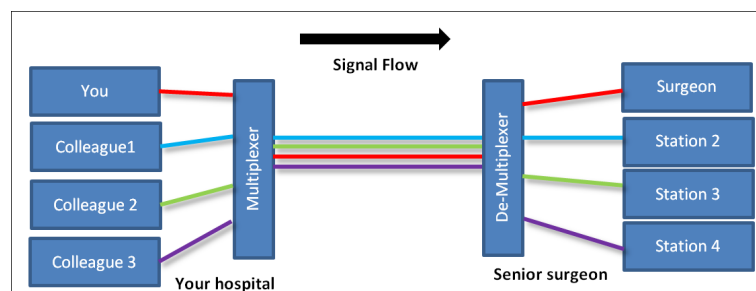

Figure 2: Simplified layout of internet framework in the case where different coloured lasers (red, blue and green as shown) are used. Source: Joveria Baig

However, with increasing demand for internet, there is a persistent need to continue to achieve faster internet. There are several ways to achieve this. One possible way is to increase the amount of data that a single colored laser can carry at a given time. Another approach is to increase the number of fiber optic cables. A third method is to introduce lasers of finely separated colors, for example, different shades of red, along with different shades of blue, etc. This latter approach, also known as wavelength division multiplexing (WDM), is the main focus of my PhD. Specifically, I am working on the design, implementation and testing of Integrated Tunable Lasers to send information down the fiber. The words tunable and integrated are crucial to my research, and will be explained in the next section.

Integrated tunable lasers

A tunable laser is one whose wavelength, or color, can be adjusted or tuned to any value. In order to understand how integrated tunable lasers are implemented, let's first understand the basic principle behind the use of a Tunable laser. On a bright sunny day when the sky is filled with droplets, we usually observe a rainbow in the sky. This rainbow is an excellent demonstration that visible light which appears to be a single white color is actually composed of many different wavelengths. These lights of different colors can be made to shine together as visible white light but can also be separated into its different color components, just as in the case of a rainbow. Lasers, on the other hand, have a property

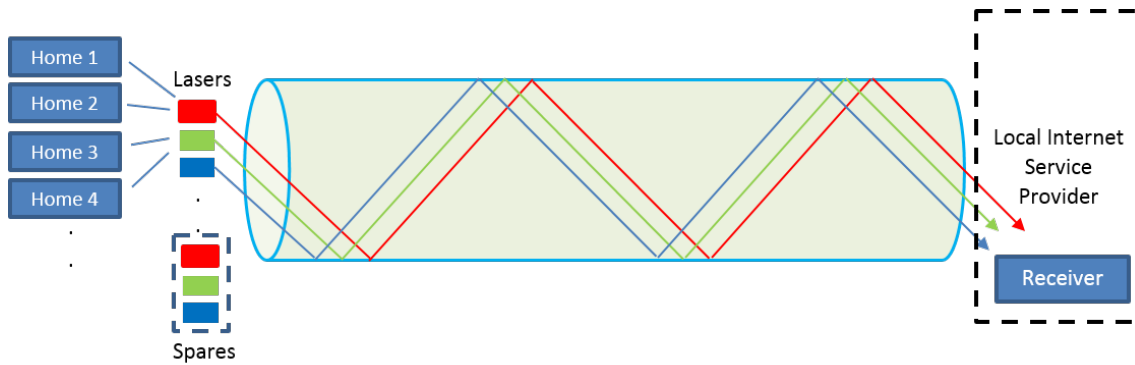

Figure 3: Simplified layout of Wavelength Division Multiplexing (WDM) infrastructure used in communication. Source: Joveria Baig

of being monochromatic in nature. Monochromatic means that inherently a single laser would have a single color. This is different from sunlight which is not monochromatic as it consists of many different colors of light. Despite the monochromatic nature of lasers, different colored lasers can be made to travel together in single optic fiber at the same time, each of them carrying different data. Although the beam altogether appears to be of a single color, data carried by the different colored lasers do not interfere with each other and can be readily de-coded at the receiver. This technique of sending different colored lasers down a single fiber increases the data carrying capacity of optic fibers. In other words, this means faster internet.

To understand the importance of tunable lasers, let's consider a simple example illustrated in Figure 3. Suppose 80 lasers of different colors (wavelengths) are used to send information along the same optical fiber. These lasers are carrying information that is transmitted from each home. For this system, another 80 lasers are placed as spare lasers in case there is a failure in the operational ones. In addition, 80 more receivers are placed to receive these spare lasers. This increases the total cost of the system significantly. A tunable laser, however, is a more cost effective solution. A single tunable laser can act as a substitute for many different colored lasers, thereby reducing the need for spare ones.

Let's return to the analogy in Figure 3 which shows that data from Home 1 and Home 2 are sent only via red laser. The data from Home 3 and Home 4, on the other hand, is sent via only the green laser. Now, imagine you are living in Home 1 and you are using internet extensively for streaming video or browsing the internet. Your friend who is living in Home 2 has an important video conference going on at the same time. So you and your friend together are requesting and sending more data over the internet which the red laser cannot carry simultaneously. Hence, it takes longer to send and receive the required data via the internet. As a result, you suffer from slow browsing speeds in Home 1 and your friend experiences lags in his conference call in Home 2. Suppose that people living in Home 3 and 4 have less data requirements, which means there is no data transfer via the green laser. In this case, red laser is over-loaded with data while the green laser is

underutilized.

My research helps to solve the above mentioned problem. My work involves design and fabrication of tunable lasers which can quickly and readily be tuned to any chosen wavelength or channel. If a tunable laser is used instead in Home 1 or 2, it could now easily tune to green color and re-distribute the load on both red and green channels. For example, the laser in Home 1 could send data via red laser while the laser in Home 2 can tune to green laser and send data via the green channel, thus avoiding overload of a single wavelength channel. This increases the total amount of data that can be sent simultaneously and allows full use of the data carrying capacity of the optic fiber, making it a far better alternative than using fixed wavelength lasers. I will be working towards designing and implementing these lasers and to be able to increase the amount of colors/ wavelengths that a single laser can tune to. Another key aspect of my PhD is the integration of these lasers into tiny packages.

Why is integration important?

The recent advances in manufacturing technology has allowed us to fabricate structures in the range of nanometers. To visualize this size, if a doughnut in this world was equal to the size of the country New Zealand, then a nanometer sized object would appear to be of the size of a football. Fabricating devices down to such small dimensionality and yet achieving the desired functionality is one of the biggest wonders of the electronic industry. Thus, by using these techniques, the tunable lasers described above can be manufactured to very small dimensions. An illustration is shown in Figure 4 which shows five lasers on a chip the size of the tip of a finger nail. This small size means less material is required to engineer these devices making it cost effective and portable. With power loss minimal at this size, these devices are energy efficient. All these factors make these tiny devices more environment friendly and much cheaper than if they were produced in large sizes, allowing large scale usability. In addition, during my research, I will be concentrating on integrating these tunable lasers with other components that are required to send and receive data and to achieve it with minimal possible power losses.

Internet in the future

Internet has proved to be enormously valuable in providing far reaching economic and social benefits globally. While internet access has been nearly ubiquitous in developed economies (nearly 82 percent in 2014), a vast majority of 4.3 billion out of world's 7 billion population still stay unconnected to the internet. Most of these people belong to developing countries where internet has tremendous potential to transform the resource based economy into a knowledge based one. The advent of internet in these countries can help save lives of millions by improving medical facilities, improving the quality of

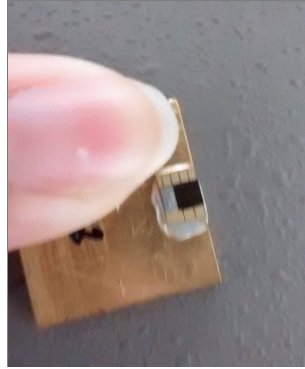

Figure 4: Comparison of the size of integrated lasers with the tip of a finger nail. The chip has five lasers on it. Source: Joveria Baig

lives of the impoverished and creating employment opportunities in areas with minimal infrastructure. But extending internet access to the vast majority of the urban poor requires a much greater bandwidth (data transfer capacity) than what is available today. Integrated tunable lasers will prove to be an excellent solution to achieve this purpose by reducing cost, size and energy consumption significantly. With the arrival of this technology, users will be able to transfer ten times more data at the same time without having to pay significantly more.

I would like to thank my supervisor Mr. Brian Corbett for his advice, guidance, and support. Acknowledgement to Science Foundation Ireland for funding this project.

Welfare Provision for the over 50s in Limerick City, 1875 to 1925

Margaret Buckley

School of Applied Social Studies, UCC

Introduction

The mortality rate and life expectancy among those aged 50 and over in Limerick City changed dramatically between 1875 and 1925. In 1875, a 50-year-old had a 60 per cent chance of living to be 60, while in 1925 a 50-year-old had an 80 per cent chance of living to be 60. This improvement was most likely due to a ‘cocktail’ effect of implemented initiatives and social policies in the areas of health, housing and social security throughout this period: the combination of the successful policies and measures would have improved living conditions and hence life expectancy. In our contemporary era of re-examination of the form and scale of welfare provision, this study aims to demonstrate the importance and power of carefully planned and administered welfare provision on the lives of ordinary people. Over the last century, Ireland has certainly changed and improved drastically as a place in which to live and grow old, but the connection between social policy and quality of life is as strong now as then.

The objective of this study is to identify which of the many developments in social policy can be associated with identifiable direct and indirect changes in the life experience of Limerick people, primarily reflected by their life expectancy, supplemented with available contemporary lifestyle data. Study of the character of what worked and what failed 100 years ago has the potential to offer valuable lessons for modern social policy formation. Mount Saint Lawrence Cemetery in Limerick City provides a unique longitudinal cross-section of society at this time. During the period 1875 to 1925, it was the main graveyard in use and the vast majority of people were buried here regardless of religion or social class. Using the transcribed burial records of this cemetery it is possible to observe the changes which occurred for the study cohort (people aged 50 and over) in terms of mortality rates, changing age at death and the place of death. One of the distinctive aspects of the Mount Saint Lawrence burial records is that the place of death was recorded rather than the home address. For example, if a person died in a hospital or institution, this is what was recorded. This aspect of the burial records allows for a measurement of the uptake of available provision, including hospital and workhouse care.

Rationale

The decision to choose the over 50s cohort rather than all age groups as the focus of study was driven by a wish to concentrate on general welfare and quality of life as opposed to purely medical considerations. These are the people who survived infant and child epidemics, maternal mortality, political uncertainty, unsanitary and overcrowded living conditions and crippling poverty to reach an age at which they were above the average life expectancy for the time. Focussing on this cohort alone will lead to more nuanced and clear indications of the impact of welfare improvements on the general quality of life. Over the 50 year timeframe covered in this study, there were changes, not just in general life expectancy (the over 50s experienced an estimated additional five years of healthy life) but also in the management of terminal illness, as indicated by the place of death of the people being studied.

The areas of welfare which would have affected the over 50s population of Limerick most were three of William Beveridge's five 'Giant Evils' — squalor, disease and want (housing, health and social security). According to *The Health and Sanitary Reports of the City of Limerick*, a total of 3,054 people lived in tenements in Limerick City, with an average of three people per room. Of that, 515 one room tenements were occupied by more than four people on average. In an attempt to address the problem, Limerick Corporation established an initiative in 1887 for the 'Housing of the Working Classes'. Between 1887 and 1925, 255 houses were built at a cost of approximately £32,000 which the corporation borrowed from both the Treasury and the bank. Unfortunately, in 1925 it was reported that, at a low estimation, 3,000 additional houses would be needed to address the issues of overcrowding and tenement living.

Place of death plays an important role when examining the impact of welfare measures. In Limerick City between 1875 and 1925, there were only two main hospitals — St. John's Fever and Lock Hospital and Barrington's Hospital. St. John's Fever and Lock Hospital provided care for people suffering from a variety of fevers or sexually transmitted diseases and was frequently overcrowded. Barrington's Hospital was established in 1831 to 'serve the poor and sick of Limerick City'. Entry to Barrington's Hospital was on the basis of a ticket from the dispensary. Neither hospital provided general care as we would know it today. The combination of minimum healthcare, precarious housing situations and virtually no social security (apart from charitable), meant that for many people the only recourse was the workhouse. The workhouse was at this time the closest approximation to what we today would consider general care. Most people could not afford to pay a doctor and many of the health issues would not have been treatable in either of the hospitals, therefore the workhouse was where people sought treatment. In examining place of death of people over 50, the importance of the workhouse can be clearly observed. The below graph indicates the proportion of people aged 50 and over who died either at home or in the workhouse between 1875 and 1925.

Figure 1: The proportion of people aged over 50 who died either at home or in the workhouse and were subsequently buried in Mount Saint Lawrence. Source: AuthorAs can be observed in Figure 1, the 'workhouse' and 'home' lines mirror each other almost exactly. The two lines together total 90% or more of all deaths (aged over 50) through the period, clearly demonstrating the restricted role of places such as hospitals, the mental hospital and religious institutions. It shows the huge social importance of the workhouse.

Impact of Initiatives

During the period 1875 and 1925, a number of initiatives were introduced to tackle the problems of 'disease, squalor and want', both locally and nationally. For example, the Limerick Borough Housing Order in 1922 allowed for the construction of 64 houses and received substantial government funding for the scheme. It should be noted that money was always an issue. The previously mentioned 255 houses which were built by Limerick Corporation were let at an average of 3 shillings and 6 pence per week. This represented about 18% of the average working income of 20 shillings a week, and would compare with a weekly rent of about €110 in 2015. At this rate, the very poor could not afford to avail of the newly built houses but it was thought that over time it would balance out, since the people who could afford to rent the new houses would vacate their old houses, which in turn would become available for the poorer in the society.

Of the legislation passed between 1875 and 1925 that addressed the problems of health, housing and social security, arguably the most well-known is the Old Age Pensions Act 1908. The introduction of old age pensions was a much needed development in social policy. However, it did not introduce pensions in the way we think of them today. It was not universal provision. Most of the conditions of payment were expected and standard, for example, to be aged 70, to be a British subject (Ireland was not yet independent) and to meet the means test requirement. Other conditions, however, were contentious. For example, if a person was in receipt of poor relief or had been in a workhouse prior to applying for a pension, they were disqualified. Therefore, it would appear that those most in need of a pension were disqualified because they were in need. Such arbitrary regulations were unfortunately commonplace. Amendments to this Act subsequently ensured that the pension became available to everybody who reached the age. It had an enormous and lasting effect on the quality of life for elderly people in Ireland, in that people could now be assured that they would not be classed as 'paupers' in their old age.

It is clear that social policy initiatives had a positive effect on changing mortality rates and quality of life. The introduction of measures to alleviate overcrowded and unhygienic housing conditions reduced the spread of disease and re-infection. Public healthcare policies led to the widespread availability of medical interventions regardless of monetary status, thus meaning that curable diseases and infections would not necessarily lead to premature death. Improved infrastructure such as functioning sewerage systems, paved

roads, footpaths and eliminating the 'pail system' ensured a marked reduction in rampaging infections such as typhoid fever. Social security provision in the form of pensions and workers insurance meant that people no longer feared abject poverty, the prospect of eviction and hunger in their old age. All of this led to markedly improved quality of life and mortality rates.

Figure 2: Cumulative Percentage of people, aged 50 in 1875, 1900 or 1925, by the age at which they subsequently died and were buried. Source: Author The policies and initiatives that were introduced during the timeframe 1875 to 1925 helped to improve the quality of life and life expectancy generally. Overall life expectancy is affected by many factors, particularly by the likelihood of surviving childhood. However, the percentage of people living beyond 85 remains very small, despite dramatic progression in average life expectancy. For this study, the concern is with quality of life rather than statistical life expectancy, so a study cohort was defined as "*those aged 50 in each year, who died at or before age 85 and were buried in Mount Saint Lawrence cemetery*". Because of the dominance of this cemetery (>90% of Limerick burials), this is a reasonable approximation of Limerick, and the age 85 was taken as a limit because detailed statistics are available only up to 1960. The effect of defining the study cohort in this way is quite striking. The Central Statistics Office estimates the life expectancy of people aged 45-55 rose by about two years in the period 1871 to 1926, while Figure 2 indicates an increase of 4 to 5 years in the study cohorts' average age at death after 1900.

Conclusion

The influence of social policy initiatives in this very significant improvement in quality of life for the middle aged will be thoroughly explored during this study. Future work will focus particularly on the disaggregation of data and study of variations from the overall pattern by area of dwelling, by circumstances of death (home versus institution), by gender and by age. Using the disaggregated data will enable links to specific documented welfare initiatives and will ultimately indicate the key characteristics of a successful welfare intervention.

I would like to thank my supervisors Dr. Fiona Dukelow (School of Applied Social Studies) and Dr. Larry Geary (Department of History) for their support and insight. I would also like to thank Limerick City Archives for all of their outstanding work. I am incredibly grateful for the generous funding provided by the Irish Research Council.

Testing times ahead? An exploration of laboratory use in Primary Care

Sharon Louise Cadogan

Department of Epidemiology & Public Health, UCC

“Blood will tell, but often it tells too much” (Don Marquis)

Demand management

Healthcare budgets worldwide are facing increasing pressure to reduce costs and improve efficiency, while maintaining quality. Laboratory testing has not escaped this pressure. A major component of healthcare budgets, the demand for testing, is increasing at a faster rate than medical activity. And, while laboratory testing is undoubtedly a valuable first step in any diagnosis, the sheer volume of testing may be conducive to waste. Laboratory services cost the Health Service Executive (HSE) approximately €469 million each year. That is over 10 times the budget of a small hospital for a whole year. In terms of volume, there are over 76 million tests performed annually in Irish laboratories. These tests are made up of both urgent and non-urgent tests and originate from various sources including A&E, inpatient, outpatient and primary care, with approximately half from the latter. Laboratory testing is an integral part of day-to-day primary care practice, with approximately 30% of patient encounters resulting in a request.

While the proportion of the health budget spent on laboratory services may appear relatively low at 3-4%, the significant costs incurred are in fact the additional downstream costs such as; the further outpatient visits and x-rays, as well as the costs to the patient of more journeys to appointments, days off work, sleepless nights worrying, or even the excessive searching of the Internet to research the myriad conditions that they may or may not have.

Why is demand management important? The practice of medicine is not easy. The correct diagnosis and best treatment plan is not always clear. Therefore, with every episode of care, the resources expended to ensure a timely and accurate diagnosis may be pivotal. That is because they influence all other decisions thereafter in the delivery of care. Hence, before requesting any laboratory test, physicians should consider the aim of the test and have a clear understanding of how the result will be interpreted and how the patient's management will be affected by the result. Some medical staff would suggest that if a test result won't change the management of a patient, it should not be done.

In a recent article for the New Yorker, Dr. Atul Gawande, who is a surgeon and public health researcher as well as a best-selling writer, made an interesting comparison between

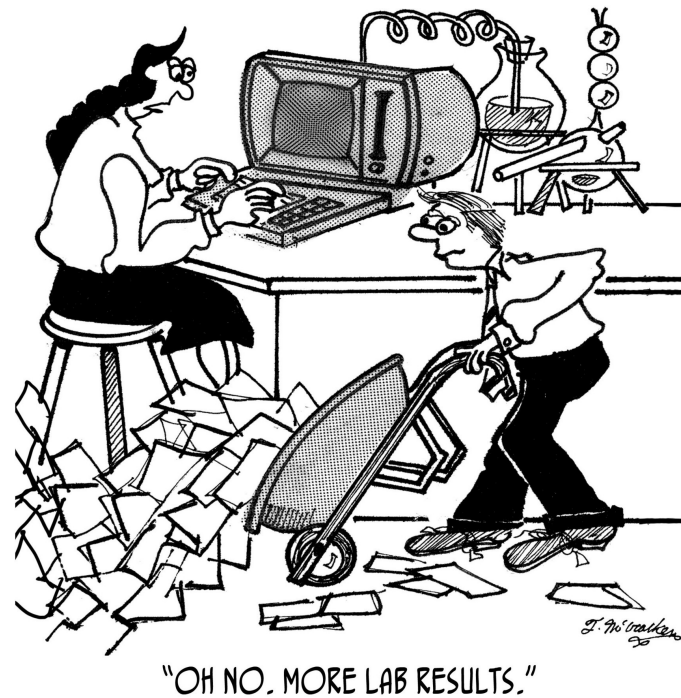

Figure 1: Oh no. More lab results. Source: www.cartoonstock.com

laboratory testing and fishing. He stated that “often, these are fishing expeditions, and since no one is perfectly normal you tend to find a lot of fish”. Are we catching too many fish, and what will we do with them? With this in mind, the effective use of resources to perform the right test at the right time is essential for ensuring the quality of patient outcomes. Also, the value of any test is subject to how likely a patient is to have a significant problem in the first place. For example, tiredness or ‘fatigue’ is a symptom of many conditions including anaemia, coeliac disease, depression, diabetes, glandular fever and underactive thyroid, just to mention a few. However, a patient presenting with ‘fatigue’ may not need laboratory investigations, or at least not for each of these conditions. The decision to request a test needs to be considered in the wider context of the patient’s clinical picture — an amalgam of their history and any findings on examination.

For example, a 31 year old male, married with two kids, who recently stepped onto the property ladder and started a new job, complains of ‘chronic’ tiredness. What are his chances of having underactive thyroid?

It’s about doing the right test on the right patient at the right time

In my research, I noted that many General Practitioners (GPs) report having a ‘battery of tests’ that they perform in the first instance to rule out many conditions. Depending on the volume and type of tests involved, this may lead to another problem caused by over-testing – over-diagnosis. Now, many believe that the diagnosis of any medical condition

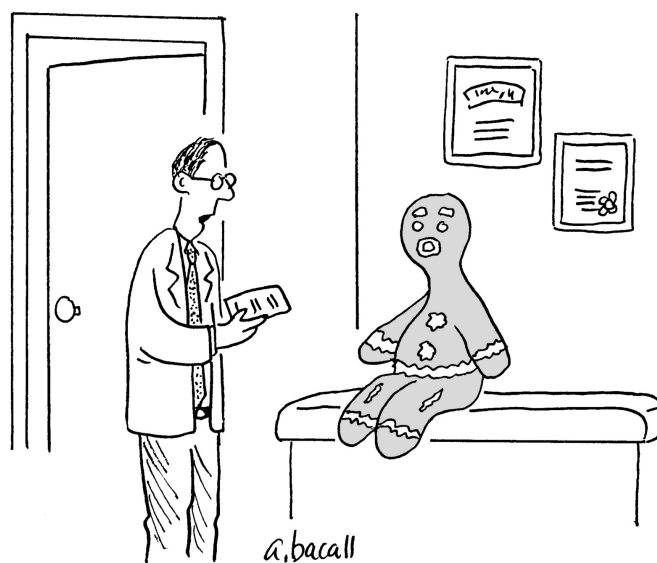

"I have your test results. Your sugar is too high."

Figure 2: I have your test results. Your sugar is too high. Source: www.cartoonstock.com

at an early stage is surely a good thing. And, of course in some cases it is, in particular for certain cancers where prognosis is dependent on early detection. However, in many other conditions, it may lead to the diagnosis of a condition that will never bother you in your lifetime. Imagine if you or a loved one were diagnosed with something that your doctor advises you to forget about because it will not harm you. Of course, you are not going to forget about it, you will begin thinking about the possibilities; how can you be sure it is harmless? Maybe I should have some treatment just in case?

Laboratory tests need to be used judiciously, and in particular should be mindful of the clinical context. The overuse, and similarly, underuse of laboratory services can stem from the physician, the patient and the broader policy context. For example, many physicians report uncertainty about when to order tests and how to interpret test results. Reasons given for this include lack of knowledge about indications, costs, insurance restrictions and inconsistent names for the same test. Similarly, patients play a role in the ineffective use of laboratory tests. Patients often have the perception that 'more care is better care' and, that extra testing may indicate a 'more thorough GP'.

Whatever the context or criteria, inappropriate testing can cause harm and lead to medical errors. Overuse can result in unnecessary blood tests and other procedures. Also, resolving the uncertainty of non-normal or borderline results may lead to further medical procedures that have costs of their own. It also increases the likelihood of false-positive results, which can lead to incorrect diagnoses, increased costs, and adverse outcomes due to unjustified additional intervention. Meanwhile, underutilization can result in morbidity due to delayed or missed diagnoses and in downstream overutilization. Overuse and

underuse of tests can both lead to longer hospital stays and contribute to legal liability.

So why is this important? Literature suggests that as much as 70% of laboratory tests may not be needed. However, a laboratory test may be initiated an estimated 30% of patient encounters in primary care. Yet, no studies to date in Ireland have examined the use of laboratory tests in primary care.

A case study: serum immunoglobulin tests

It is likely that wasteful requesting of laboratory tests occurs across all tests, and similarly across all disciplines of medicine. However, it is not feasible to examine all tests, and, for the purpose of this research we decided to explore requests for quantitative serum immunoglobulins.

What are serum immunoglobulin tests and when should they be used? Serum immunoglobulin tests measure the level of immunoglobulins (antibodies), in the blood. Antibodies are proteins made by the immune system to defend against antigens, such as bacteria, viruses, and toxins. Quantitative serum immunoglobulin tests are used to detect abnormal levels. Low immunoglobulin levels characterise some antibody immunodeficiencies (when the immune system isn't working properly). These are really rare. Meanwhile, high immunoglobulin levels (polyclonal gammopathy) are often found in liver diseases, chronic inflammatory diseases, haematological disorders, cancers and infections.

Aim of this research

The aim of this PhD is to explore the efficiency of laboratory use among GPs in the Cork-Kerry region. This firstly involves identifying any GP variation in requesting patterns. This requires the extraction of data on all immunoglobulin tests requested by GPs in the Cork-Kerry region for a time period of one year.

So why does this physician-to-physician variation exist? That leads to the next component of this research; a qualitative study (using semi structured interviews) exploring GP attitudes on test requesting and referrals to outpatient clinics.

Both of these study components inform the remainder of the PhD: finding a plaster to control the excess blood. That is, an intervention to promote optimum laboratory use will be developed, implemented and evaluated for effectiveness. This intervention will be designed based on findings of previous two studies in the PhD, along with the recommendations from the international literature on what has previously been effective.

The impact of this research

With testing times ahead for healthcare budgets, this research is timely and could have an important impact on reducing health service costs and laboratory workload, while

improving patient care. Regardless of the effectiveness of the intervention, this research highlights some key issues around testing, including uncertainty about when to test and difficulty interpreting the results.

It is anticipated that findings from this PhD will inform public policy and good practice guidelines for the use of laboratory test, making the testing times ahead, less testing!

I would like to thank my supervisory panel: Professor Mary Cahill, Professor John Browne and Professor Colin Bradley. I would also like to acknowledge the Health Research Board PhD Scholars Programme for funding this research.

Smart Cities — How can we get bridges talking?

Paul Anthony Cahill

School of Engineering — Civil & Environmental Engineering. , UCC

The story of civilization is, in a sense, the story of engineering — that long and arduous struggle to make the forces of nature work for man's good. (L. Sprague de Camp)

Technology — evolving but not universally

With the abundance of smart technology that has been developed in recent times, society is ever progressing to improve the comfort, quality and safety of our lives and the world around us. Such technological developments have resulted in great improvements in a variety of fields and have greatly enhanced our communications, leisure and health. However, much of the most fundamental infrastructure that we rely on most for our everyday needs has yet to benefit from the information technology revolution, namely civil infrastructure. From the water we use first thing in the morning to shower and brush our teeth, to the roads and bridges we use to travel, civil infrastructure is vital to our everyday lives. Not only that, but improved efficiency in all these areas is required to help protect the environment for future generations and reverse the excess that has damaged our planet in the past two centuries.

How smart are smart cities?

There has been intense focus in recent years on the development of smart cities, which act as a system with technology being integrated into all aspects of life. Amongst a host of other engineering infrastructure, such as power, transport around such cities has received great benefits from these developments. It is only in the customer interface that benefits of such technology have been seen with real time traffic and public timetables information being freely available, whilst the actual infrastructure, such as bridges that sustains this transport system, still remains lacking in many aspects. The health of such bridges are still determined primarily through visual inspections, which can only indicate surface degradation of the bridge and are dependent on the experience and competence of the inspector. The other options currently available include wired sensing, which requires untenable levels of man hours and disruption to the service, destructive testing, which involves damaging the structure to determine its health before repairing the imposed damage, or wireless sensors, which rely on batteries that have short lifespans and need frequently to be changed. The ongoing development of smart technology raises the

question, how can we integrate such technology with bridges? How can we improve our knowledge of the health of bridges, which will help prioritise maintenance for improved safety and economics? And, finally, can we get bridges talking and truly develop smart cities?

Bridges as a source of energy

My research focuses on the integration of smart energy harvesting sensors with civil infrastructure, with emphasis on bridge structures. These sensors are designed around active piezoelectric materials, which have the ability to convert changes in strain energy into electrical energy through the direct piezoelectric effect. What this means is that when attached to a host structure, the sensor will convert any movements in the host into electrical energy and so has the potential to create a wireless sensor node which is independent of external power supplies, such as batteries. There have been intense investigations into the development of such energy harvesting devices but this has primarily focused on when the sensors undergo stable simple harmonic motion, whereby the hosts' movement has a constant frequency and amplitude. In reality, the vast majority of civil infrastructure do not experience such motion but instead experience live loadings, which are best described as unstable loading, such as the wind or vehicles passing over a bridge. It is therefore imperative to investigate how the sensors will interact with structures under real world conditions to fully realise their potential.

One such interaction that is very appealing is the development of such sensors for train bridges (Figure 1). This is due to trains having such a large load and also the timetabled nature of the rail network allows for a highly predictable level of loading on the bridge. This means that the energy harvesting sensors will have not only a high level of electrical energy output but also be highly predictable in the amount of energy it can harvest in a given time period. Train bridges are therefore the perfect host structure with which to integrate smart energy harvesting sensors. The challenge therefore is the design of the energy harvesting sensors which can capture the live loading of the train passage and accurately calibrate the device for other applications such as damage detection and alerts for the control of vibrations in a structure.

A close-up view of the energy harvesting sensors

There are two device configurations that I am investigating for the creation of the energy harvesting sensor. The first type of device is a patch based solution, where the energy harvesting material is attached directly to the bridge by using a bonding agent. In this way, electrical energy is generated by the harvester due to the changes in the strain energy on the surface of the bridge as a vehicle passes over it. The second type of device is a cantilever based harvester. The cantilever based harvester is excited by the acceleration



Figure 1: Example of Train Passage over Bridge. Source: Author

of the bridge and transfers this vibration energy to its substrate which is then in turn converted into electrical energy by the piezoelectric material. The cantilever device is attached by its base to the host structure and has a tip mass at the free end (Figure 2). This tip mass can be changed so that the natural frequency of the harvester can be matched to that of the bridge, this is an optimisation of the harvesting device.

As previously mentioned, to maximise the energy harvesting output of the sensor, it must be designed in such a way so as to match the natural frequency of the bridge or the frequency at which the maximum amplitude of vibration occurs. Most often these two



Figure 2: Cantilever Device for Energy Harvesting from Train Induced Vibrations in Bridges. Source: Author

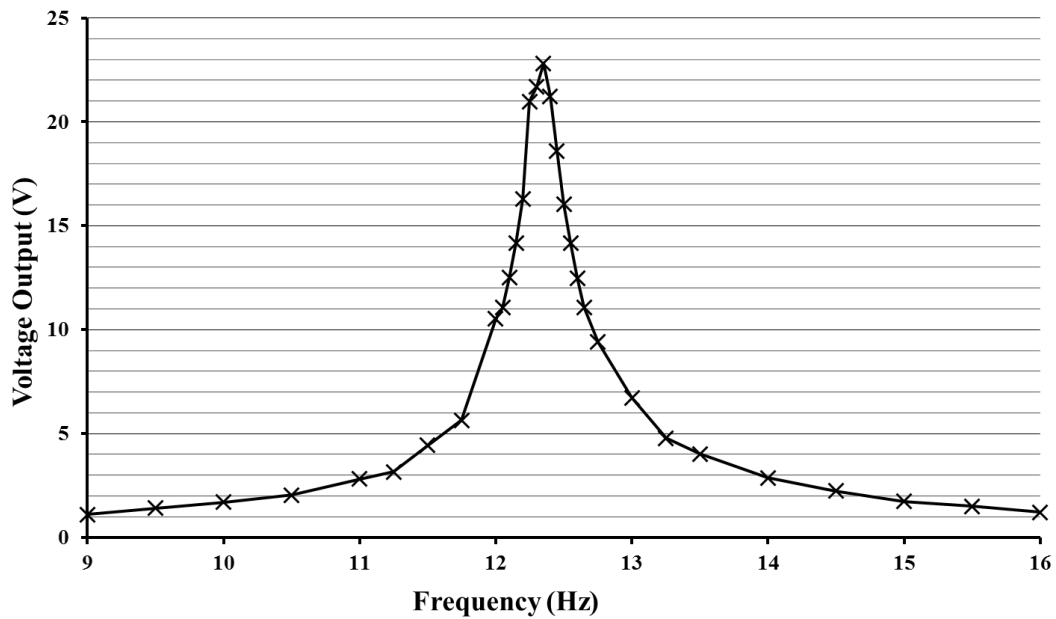

Figure 3: Example Voltage Response versus Frequency of a Cantilever Device Tuned to 12.6Hz. Source: Author

frequencies are the same however they may be different depending on the type of bridge being considered. The cantilever device returns a maximum voltage output at a single frequency, which means as we move away from that frequency the amount of electrical energy that is generated drops sharply (Figure 3). Therefore, it is imperative that the natural frequency of the device is tuned correctly to that of the host structure, so as to maximise the potential energy that can be harvested.

The amount of electrical energy that can be harvested from a single train passage is quite low, in the range of milliwatt, however with the addition of a storage circuit and battery, the energy which is harvested from each train passage can be stored. This can then be used to power a wireless node which can transmit data such as environmental information or, more appealing, the health of a bridge to a centralised computer. If all bridges were to be fitted with such energy harvesting sensors, the health of our cities bridges could be monitored using a single computer.

A health check-up for bridges

It is often the case that the only time that we hear about damage in bridges is when the worst case happens and sudden, catastrophic collapse occurs. However, damage can occur in many different forms and can attack bridges in many different ways, from the most visible, such as vehicles striking the bridge and cracks developing (Figure 4), to the more concealed, whereby the internal sections of the bridge suffer damage such as corrosion. Energy harvesting sensors can act as a monitor for such damage and can enable authorities to prioritise maintenance or alert to the need for immediate action. This can be done in



Figure 4: Evolution of Damage Crack in a Reinforced Concrete Beam. Source: Author

two ways. First is to use the voltage signal directly and convert from the time to frequency domain. As damage affects a bridge, the natural frequency of the structure changes and as it does so, the voltage output will be influence, which will therefore make it possible to track the evolution of the damage within the host bridge. The second way of detecting damage is to use the amount of energy harvested by the device. As damage affects the bridge, the acceleration and strain variations which provide the necessary means for the device to harvest energy will change. The amount of energy which is harvested will change and thus indicate the presence of damage. Through the use of an array of such devices, the location and magnitude of the damage can also be ascertained, which will provide invaluable information for bridge maintenance authorities and connect the bridge to the smart cities.

Bringing the bridge to the lab

Full scale testing of train bridge interaction is costly in terms of economics and man hours. It is therefore much more attractive to determine the performance of the energy harvesting device and its applications in a laboratory based setting first. As part of my research, I have developed a procedure that will achieve this objective (Figure 5). The procedure takes into account the type of device which requires validation and the type of data which is available. Should both strain and acceleration data be available, from either experimental or theoretical studies, both types of devices can be validated. The performance of the cantilever device can be determined by using a Permanent Magnet Shaker, which can replicate any given accelerations in a laboratory setting, and applying the same accelerations as that which are caused by train — bridge interaction. This means that the scale of the applied acceleration experienced by the device would be the same in both cases and thus the cantilever devices performance would be equal in the lab as it would be attached to the bridge. Similarly for the patch device, through the use of the procedure but this time using a fatigue testing device which can apply the same strains as that of the train — bridge interaction, the output of the patch device can be determined. The application of damage detection can also be verified in a laboratory setting through this procedure as the strains and accelerations of the damaged and undamaged cases for the bridge can be replicated and the performance of the bridge for both determined.

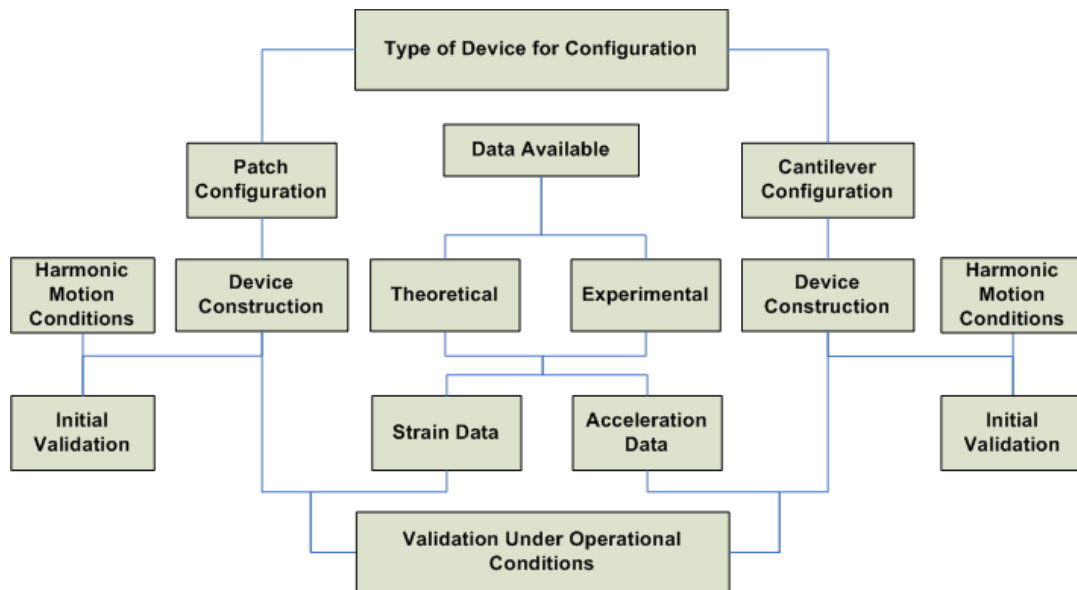

Figure 5: Procedural Flow Chart for Validation of Energy Harvesting Sensors for Train-Bridge Interaction. Source: Author.

Source: Author

Self-powered wireless sensors — A voice for bridges

Through the use of my proposed energy harvesting sensors, coupled with an AC — DC storage circuit and a wireless node, wireless sensors can be developed for bridge applications. The health of the bridges will be determined in a very inexpensive way and the information on maintenance requirements will be greatly enhanced. These smart energy harvesting sensors will allow for bridges to finally gain a voice in the smart cities around us.

The author is a student in the Dynamical Systems & Risk Laboratory (DSRL), School of Engineering, UCC under the supervision of Dr. Vikram Pakrashi and Dr. Alan Mathewson. The author would like to thank Dr. Nathan Jackson for his assistance with this research. This research was partly carried out at Tyndall National Institute.

Blue mountains, empty waters: the evolution of Chinese landscape painting under the influence of Chan Buddhism

Rudi Capra

Department of Philosophy, UCC

In this paper I will describe the evolution of Chinese landscape painting throughout the period which led from the awareness of a primordial aesthetics to the emergence of Chan Buddhism. In fact, since the Chan tradition had a pervasive and profound impact on the Far Eastern cultures, it should be analysed in a more rigorous manner than it was in the past.

In particular, my thesis is that the Chan Buddhism consistently influenced the aesthetic canons and artistic themes of the epoch, expressing through the artworks original concepts and relevant philosophical ideas.

Pre-Buddhist Aesthetics

Buddhism came very early to China, brought by merchants along the Silk Road and by the sea-routes. It started spreading during the Han dynasty (206 BCE — 220 CE), and the first historical proof of Buddhist influence dates back to the 1st century CE. In 148 CE the Pali Canon was translated in Chinese by the monk An Shigao, formerly a Parthian prince; it is still known as the most ancient translation of a Buddhist text in Chinese.

Despite that, we can still talk of 'pre-Buddhist Aesthetics' in Chinese Arts, firstly because the Buddhist influence did not arouse a sudden revolution. Instead, Buddhism has been absorbed in a long process of integrations and modifications. Secondly because we can already individuate, before the coming of Buddhism, some very interesting features in artworks that are typical of Chinese expression.

The consolidation of primitive forms of devotion in a social framework implies the codification of rites that express religious feeling through aesthetic devices. That is why music had a crucial role in the progression of artistic expression in Chinese culture: it was a binding agent between the common aesthetic consciousness, the individual need for sensuous pleasure and the social renewal of religious conventions, essential to protect the hierarchical system. In ancient China rites and music 'were both unified and distinct, [...] they at once worked together and had a division of labor', according to Li Zehou in his Chinese Aesthetic Tradition.

Nevertheless music also had a unifying power, as illustrated in the Book of Rites:

Music is the harmonization of heaven and earth; the rites order heaven and earth.
When there is harmony, the myriad living things are in accord; when there is order,
all things are differentiated.

This ritual function repeats one more time the deepest beliefs of ancient Chinese wisdom: that the numerous oppositions into which reality is divided must be brought back to an ideal unity, that is the mirror of true harmony.

There is no divine anger, no overflowing pain, no intolerable grief in classic Chinese art, whether from mythology to painting. All forms of art are consecrated to a poetic serenity, a composed equilibrium where sorrow is represented at most by a fragile sense of melancholy. We are far from Achilles' murderous rage, Oedipus' unmentionable sin, Ajax's crushing madness.

In fact, it is important to underline the tight link between artistic creation and pedagogic purposes in Chinese art. Artworks were never completely untied from the social dimension. Instead of being the result of an individual expression, as they are mainly perceived in the West after Romanticism, Chinese artworks were rather individual interpretations of a common substrate of knowledge and beliefs.

Furthermore aesthetics and art criticism in China have been developing in parallel with pictorial art since its very early appearance. Thus we possess a huge number of texts trying to describe art purposes and techniques, to fix rules for the evaluation of paintings, to comment on an artist's competence and intentions.

The most important art critic of this period was Xie He, who in his 'Classified Record of Painters of Former Times' (Gu huapin lu, about 550) codified the famous 'Six Principles' of general painting. They are settled in order of importance, and the first principle can be translated as 'spiritual resonance'.

Originally 'spiritual resonance' probably meant that a successful painting needs, more than anything else, to capture the 'spirit' of the depicted. Briefly, the vital force (qi) that animates the natural world should animate the painting as well. And conversely, the art piece should have a spontaneous adherence to natural world, showing no affectation. We could maybe make reference to the Western notion of 'inspiration', but there is more: the principle of spiritual resonance involves a sentiment of belonging to the cosmic unity, and we notice a dialectic between natural macrocosm and artistic microcosm.

The second principle is the 'internal hierarchy of the strokes', which concerns not only the texture of brush traits but also the importance of a coherent style linking drawing, colouring and writing.

The principle of resemblance deserves 'only' the third place in this scale, despite its enormous importance in the Western figurative art tradition. The fourth concerns the application of colours, tones and layers. In fifth place we find another pivotal principle of Western

paintings, the organization of space and depth. Finally, there is stylistic adherence to ancient models.

During the Sui and Tang dynasties landscape painting achieved an unprecedented popularity due to the 'Green-Blue' landscape style inaugurated by Zhan Ziqian (about 550-600) and continued by Li Sixun (651-716) and his son Li Zhaodao (about 670-730). The only left painting of Zhan Ziqian is 'Strolling about in Spring'.



Figure 1: Detail from Zhan Ziqian, 'Strolling about in Spring', ink and colours on silk, Palace Museum, Beijing. Source: Wikimedia Commons. "Stroll About InSpring". Licensed under Public Domain via Commons —

https://commons.wikimedia.org/wiki/File:Stroll_About_InSpring.jpg#/media

This painting establishes a double innovation in the history of Chinese art. Firstly, the beginning of the Green-Blue style, and, more important, the invention of a new kind of artwork, called Shan shui (mountains-waters). In fact Shan shui is the equivalent of the word 'landscape' in the Chinese language and they used to describe landscapes with the juxtaposition of distinctive features of the land. In this attitude we find once more an allegory of the mystic dichotomy characterizing Daoist cosmology, the mountains representing the solid reality of the Earth, exemplified by the principle of yang, and the waters recalling the imperceptible essence of yin.

Even the colours form a bright, unreal dialogue: green and blue, the colours of wood and water, dominate the scene, with some accents of white and gold. Chromatic combination follows elemental rules exposed in classic books of Chinese tradition, reminding the

observer of the correct relationships of elements and their mutual dependence.

The use of shading to suggest distance or proximity creates a primitive perspective that seems to emphasize the extraneousness of the natural world to men's lives, reminding the observer how relative human wills are — not vain, just limited whether compared to the infinity of space and time. By redimensioning human ambitions the painter absolves a pedagogic duty, transmitting the right comprehension of everyone's role.

It is important to note how the depiction of waters and cloud is treated, because we will find a very different solution in latter paintings: clouds are fully drawn, even with outlines, coloured of a glittering white, and water's movement is simulated by a texture of subtle crossed lines. The qinglu (Blue and Green) style is renowned for the clearness of lines, the formal equilibrium and the attention for details.

Early Chan Aesthetics: the ink wash paintings

Originally Daoism shared with yoga the consciousness of a cosmic unity, the practice of meditative forms, the evaluation of body as inseparable from mind and the consequent attempt at perfecting awareness control of breath and actions, and also an analogical thought founded on natural cycles. At the beginning of 8th century the Sinification of Buddhism was almost completed, giving birth to the Chan tradition that we could describe as a spontaneous evolution of Buddhism under Daoist influences.

Chan masters had started regarding early Daoist texts as brilliant examples of enlightened prose. In particular they were attracted to the notion of wu (nothing/emptiness/being-without) from Laozi and from the mistrust of Zhuangzi towards logical argumentations and the capacity of language to seize reality.

The famous metaphor of the empty jar from Laozi in the Daodejing explains that a jar is useful due to its emptiness (wu); once it is full, it is useless. Then the empty space inside the jar represents the potentiality or virtue (de) of the object. At the same time wu is the essential condition of nature because the actual state of objects is not determined once for all (it is 'empty' of permanent essence). Nevertheless, their instability (and therefore their in-determinability from a theoretical point of view) constitute their final virtue (de), id est the infinite variety of possible determinations.

At the same time, the Chan Buddhism emphasizes the mutual interpenetration of all phenomena in the Universe, expressed through the metaphor of Indra's net:

Far away in the heavenly abode of the great god Indra, there is a wonderful net which has been hung by some cunning artificer in such a manner that it stretches out infinitely in all directions. In accordance with the extravagant tastes of deities, the artificer has hung a single glittering jewel in each eye of the net, and since the net itself is infinite in dimension, the jewels are infinite in number. [...] If we now arbitrarily select one

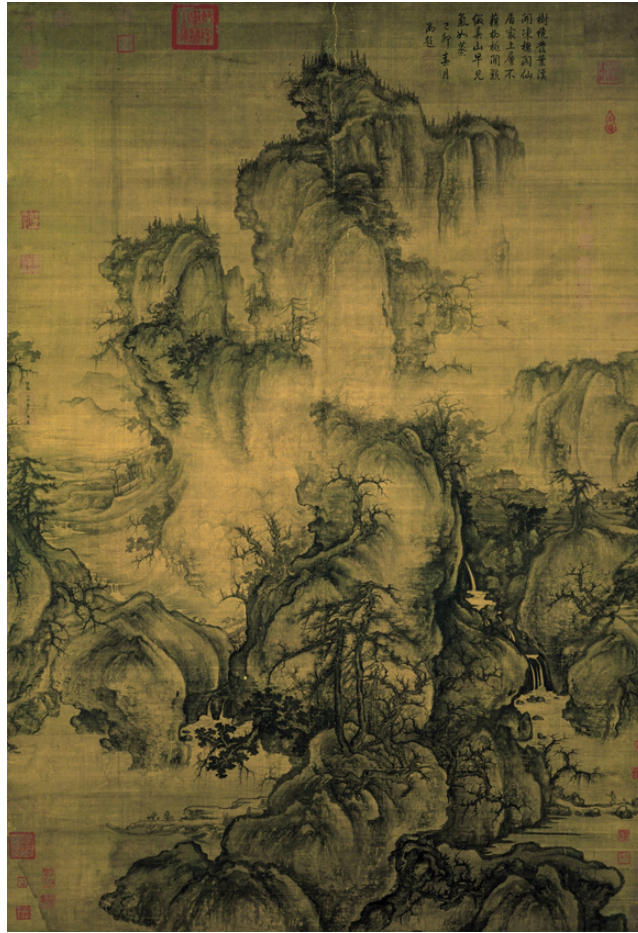

Figure 2: Guo Xi, 'Early Spring', ink and colours on silk, National Palace Museum, Taipei. Source: Wikimedia Commons. "Guo Xi — Early Spring (large)" by Guo Xi . Licensed under Public Domain via Commons —

[https://commons.wikimedia.org/wiki/File:Guo_Xi_-_Early_Spring_\(large\).jpg#/media](https://commons.wikimedia.org/wiki/File:Guo_Xi_-_Early_Spring_(large).jpg#/media)

of these jewels for inspection and look closely at it, we will discover that in its polished surface there are reflected all the other jewels in the net, infinite in number. Not only that, but each of the jewels reflected in this one jewel is also reflecting all the other jewels, so that there is an infinite reflecting process occurring.

As the cycles of seasons, of life and death, of fullness and emptiness, even being and non being are generated one from the other, co-dependent and co-arising throughout the time and the space. There is no space, in the Chan world's view, for a rigid Parmenidean dualism in which Being and Non-Being are mutually exclusive.

I would like to examine here a painting from Guo Xi, painter from the 11th century, 'Early spring'. It is a Shan shui painting rather different from the previous one: empty spaces are used to open abyssal cliffs in the middle part of the painting, to suggest the placidity of waters, to erode contours of objects, to unfold the undefined horizon in front of the observer. The presence of man is spread along the scene, but so gently integrated in the environment that is hardly visible.

The comparison between the first and the second is striking: in the earlier painting clouds are drawn with clear contours and fully coloured with a brilliant white; the movement of the water is rendered by a subtle crosshatching. In the latter instead, skies and waters are merely empty and contours faint and emerge from a hazy vacuum.

The observer is invited to watch at the painting as an unfolding process, seizing reality in its ineffable development. Temporary oppositions are dissolved by the work of the artist, who represents the unrepresentable interpenetration of being and non being, men and nature, streams and mountains. Quoted from Shitao, artist, art theorist, Buddhist and Daoist monk, in *The Chinese Theory of Art* by Lin Yutang:

One might think of the sea only as the sea and of the mountains strictly as mountains only, which would be a mistake. To me mountains are seas and seas are mountains, and seas and mountains know that I know.

Chan masters also advocated the positive value of immediacy within the learning process, and ink wash paintings indeed point directly to the observer's conscience by depicting a floating world that does not need any further conceptualization. Their purpose is not descriptive, but rather expressive of a philosophical world view. For these reasons ink wash paintings can also be considered as useful instruments to help Chan disciples in their way to enlightenment.

Conclusions

Finally I can summarize some fundamental points of this analysis.

First of all, Buddhism and earlier Chinese values combined with each other in a well-matched composition which is hard to split into its multiple origins. This fortunate mix was reflected in artworks. The considered landscapes present some important affinities, for example the handscroll format: whereas in the West the artist always makes reference to a delimited space such as a frame, a wall or a recess, Chinese paintings can be rolled and unrolled in a long, narrow strip.

Therefore a landscape unfolds and develops like a musical theme, rather than being a fixed window projected on the natural world. Even the clearness of sight is replaced by the uncertainty of a melody, because whereas Western paintings are often seized in a single gaze, Chinese landscapes instead invite the observer to hesitate on the depicted, to discover the scenery by directing the glance slowly across the picture. Like a musical theme, a Chinese landscape requires time to reveal itself, and this feature recalls us to the centrality of music in primitive Chinese aesthetics.

Concerning the influence of Chan Buddhism on Chinese aesthetics:

- It is impossible to claim from an historical point of view that the influence of Chan Buddhism has determined the creation of ink wash painting, but without any

doubt monochromatic ink landscapes quickly became a typical expression of Chan world view.

- Monochromatic ink landscapes possess strong philosophical and religious implications. As we can see in the second painting, the landscape sinks in a mystic haziness that seems to swallow and release the raw substance. This painting can be read as a philosophical statement, id est the raising of impermanence as a permanent feature of the Universe and the co-dependent arising of all phenomena.
- The Chan Buddhism appropriated monochromatic ink painting style emphasizing extreme features to express important concepts concerning reality. We could say that earlier paintings represented nature, whereas in Chan Aesthetics paintings described the nature of nature.

The soteriological dimension of Buddhism lent to the paintings an atmosphere of relaxed gaiety, where a melancholic flavour is subdued by an overall peace. Compared to previous artworks, Chan paintings are provided with a superior awareness, not only technical, but also philosophical.

This peculiar world view is far from the Dionysian spirit of tragic rebellion in front of the cruelty of nature. Despite suffering and isolation the painter never feels abandoned, because he is part of a cosmic communion, as is beautifully shown in this poem from Wang Wei:

Leaning alone in the close bamboos
I am playing my lute and humming a song.
Too softly for anyone to hear –
Except my comrade, the bright moon.

John McGahern and the temporalities of modernity

Yen-Chi Wu

School of English, UCC

“This is how one pictures the angel of history. His face is turned toward the past. Where we perceive a chain of events, he sees one single catastrophe which keeps piling wreckage upon wreckage and hurls it in front of his feet. The angel would like to stay, awaken the dead, and make whole what has been smashed. But a storm is blowing from Paradise; it has got caught in his wings with such violence that the angel can no longer close them. The storm irresistibly propels him into the future to which his back is turned, while the pile of debris before him grows skyward. This storm is what we call progress.” (Walter Benjamin, “Theses on the Philosophy of History”)

Introduction

How does time flow? One might simply answer: from the past to the present and to the future. Indeed, this is perhaps the most common conception of time, which is based on linear progression. In fact, such a conception is so common that one rarely thinks of other possibilities of the temporal movement. When we uncritically apply this idea to history, however, we miss out on the complex flows within culture.

Conventional historicism relies on this linear temporality and perceives history as a “progress” from the primitive to the pre-modern and to the modern. In this regard, lifestyles and practices in the past are simply superseded and “improved” by more progressive modern conditions. The linear conception of time may be innocuous in itself, but conventional historicism has unwittingly created a modern myth in progress, including the dichotomy between tradition and modernity. With the notion of progress, tradition is relegated as old-fashioned, regressive and conservative; while modernity is lauded as enlightening, rational and liberal. But is this progressive modernity so unanimously unquestionable, even in different locations?

Walter Benjamin had pointed out the peculiar violence in the modern myth of progress. In his depiction of the Angel of History, Benjamin sees the angel facing backwards while the forceful wind of progress propels him to move forward; before his eyes are debris of the past that are crushed and scattered in the progression of history. From a postcolonial perspective, Benjamin’s critique of historicism and modernity was particularly illuminating. In the colonial era, colonial modernity was used to relegate the colonial subjects as pre-modern so as to justify the colonist’s dominance. In the anti-colonial stage, however, the colonized reversed the game by embracing the “pre-modern” features as a prided

tradition. In the postcolonial society, therefore, the relationship between tradition and modernity was especially fraught, and the violence of progress was particularly palpable.

From traditional to modern Ireland

In the Irish context, the mid-twentieth century is often regarded as the watershed in which traditional (Catholic, rural) Ireland gave in to modern (liberal, economically-driven) Ireland. In the historicist sense then, traditional Ireland is now gone, replaced by a more progressive modern Ireland. In this vein, how do we assess a modern writer whose novels primarily invest in the rural Ireland of the mid-twentieth century? Is he hopelessly nostalgic, or is he proposing a more refined conception of historicism and modernity by persistent returning to the Irish rural past? John McGahern is such a writer that deserves more critical attention to the complex temporalities embodied in his work. His writing career and his novels register temporal qualities that defy the modern linear progression. My project, foregrounding the issue of temporality in John McGahern's work, examines the writer's relationships to Ireland's past as well as to its modernity.

Three stages of McGahern's novels – circling back to the rural past

McGahern's writing career spans across half a century, from the early 1960s to the 2000s, and witnesses Ireland's rapid modernisation. His novels are often seen in three stages: the early novels bear strong social critique of the insular rural Ireland; the mid-career novels depart from the rural setting and are more experimental in writing style; the later novels return to the rural Ireland of his childhood but the narrative tones have become gentler.

The social critiques in his early novels subjected McGahern to controversy. His debut novel, *The Barracks* (1963), enjoyed a general welcoming reception. The novel has an autobiographical undertone. The female protagonist, like McGahern's mother, is diagnosed with breast cancer and seeks to come to terms with her illness and impending death. Her husband, similar to the author's father, is a moody police sergeant capable of violent emotional outburst. McGahern thus scrutinizes the insular rural Ireland, as mirrored in the depressed household.

His second novel, *The Dark* (1965), probes the touchy issues of domestic and clerical child abuse. The novel famously opens with a detailed scene in which the young protagonist is stripped naked while his father threatens to whip him and causes him to lose bladder control. The sexual undertone in this scene is brought to light later when the father, sharing the bed with his son, caresses the boy to help himself to reach orgasm. To escape from his abusive father, the boy seeks a clerical career. Unfortunately, when consulting for advice, the boy is met with a Father who makes improper sexual moves and reminds him of his own father. These patriarchal figures serve as strong social critiques of the insular

rural Catholic Ireland. The novel was banned by the Irish Censorship Board for contents of indecency and vulgarity. As a consequence, McGahern lost his teaching job.

Stigmatized as a dirty writer for the banning of his book, McGahern was forced to self-exile. His mid-career novels, following his home-leaving, are often set in the big cities of London and Dublin. The themes consequently departed from the author's previous focus on rural Ireland. *The Leavetaking* (1974) is a semi-autobiographical novel, following the last day of a Catholic schoolteacher before his sacking. The narratives interweave past and present events, giving accounts of the protagonist's becoming a teacher and his year on sabbatical in London where he marries a divorced American woman outside the Church. The marriage is disapproved by the school at his return, and the protagonist is therefore dismissed from his teaching position. Even though Catholic dogmatism still plays a major role, the novel focuses more on the London period when the protagonist tries to sort himself out. The novel thus, as the title suggests, takes leave from the rural Ireland, as McGahern did with his exile.

The Pornographer (1979) is a whimsical yet profoundly philosophical novel that looks at sex, death and art. The protagonist makes his living by writing cheesy pornographies, which are sometimes based on his real life experiences. Accidentally impregnating a woman he does not love, the protagonist struggles to take the responsibility, which he ultimately refuses. This seemingly demoralized man, however, is movingly attentive to his dying aunt in the rural area. The complexity of this pornographer thus showcases the dual sides of a man who is indulged in urban individualism and yet capable of taking moral responsibility in a rural context.

With McGahern's return to County Leitrim with his wife, the diminished rural themes in his mid-career novels resurfaced in his latter ones. His last two novels relocated back to the rural Ireland of his childhood. Different from his early works that carry social critiques of rural Ireland, McGahern's latter novels use gentler narratives that seemingly eulogize the disappearing rural civilization. McGahern's career trajectory thus shows a circling back to where he had begun, but the writer had learned to see the rural world with different eyes.

The strange sense of timelessness

The latter two novels, in addition to marking McGahern's circling career trajectory, register complex temporal quality in the writing. In fact, McGahern's writing is characteristic of recurring characters and recursive narratives that render his body of work an organic whole. Viewed in its wholeness, McGahern's novels seem to be the author's effort to revise and to hone the same stories over and over again. In his latter two novels, this trope of recurrence and repetition consummates in a sense of strange timelessness.

In his review of Thomas O'Crohan's *The Islandman* (1929), McGahern praised "the strange

sense of timelessness” in the memoir. The unit that marks the progression of time is the day. As one day ends, a new day begins. In this way, the memoir registers a sense of repetition and renewal. Moreover, the memoir records the non-modern life of the people in the Great Blasket Islands, which seems to stand outside national history. These features together contribute to the strange timeless quality in the book. Critics often agree that McGahern’s latter two novels have achieved similar timeless quality. The progressions of both novels are marked by seasonal changes, rituals and the family members’ leaving and homecoming, which eludes the chronological time.

Amongst Women (1990) is a family saga, telling the story of the Morans of Great Meadow. While focusing on one family, the novel also showcases Irish history in the latter half of the twentieth century. The story opens with the Moran girls’ attempt to revive the Monaghan Day so as to put life in their weakening father at his old age. The narrative then shifts back to the actual Monaghan Day and follows the children’s developments from their adolescence to young adulthood, which account for the main body of the novel. The narrative finally returns to the narrative present and ends with Moran’s funeral. The temporal progression thus embodies a circling quality instead of a linear one. The depiction of the Moran’s rural homestead, the Great Meadow, as a place where “nothing but the years change” intensifies the strange timeless quality in the novel.

McGahern’s last novel, *That They May Face the Rising Sun* (2002), is an unconventional story without the development of a plot. The novel focuses on the lives of a lakeside community in rural Ireland, reminiscent of McGahern’s country house in County Leitrim. The main protagonists are the Ruttledges, a middle-aged couple who returns to the rural Ireland after years of working in London, like McGahern and his wife. The narrative is often interrupted by accounts of their neighbours’ backstories, usually provided by the nosy yet charming Jamesie. The recursive narratives are complimented by the theme of repetition and revival. There are nearly identical phrases and paragraphs in the narrative, which contribute to a sense of ritual that marks the passing and renewal of time at the same time. The title of the novel comes from the local funeral ritual, according to which the dead are buried with their heads in the west, so that they may face the rising sun when they awake. This sense of ritual and resurrection also contribute to the timeless quality, as the time passes and returns, defying the linear progression that moves only forward.

In addition to the recursive narratives and the trope of revival, the images of clock also play a significant part in *That They May Face the Rising Sun*. In Jamesie and Mary’s house, there is a wall of pendulum clocks, but these clocks are unsynchronised. When Jamesie’s brother Johnny died, they stopped the clocks in respect to the local funeral ritual. After the funeral, Jamesie and Mary hired a clocksmith to rewind the clocks, but there are still two clocks that chimed late. The clocksmith is booked to return for a final adjustment, but the novel ends before his return. It is therefore uncertain if the two unsynchronised clocks would finally catch up with other clocks, or if they would be left alone. The broken rhythm

carried in this image of unsynchronised clocks neatly represents the strange temporal quality in McGahern's oeuvre. Instead of moving in a linear progression toward modernity, McGahern's novels probed the different temporalities of modernity.

Conclusion

In view of McGahern's writing career that circles back to the rural Ireland of the mid-century and the timeless quality in his latter novels, McGahern is usually associated with the traditional and older rural culture. The corollary is that McGahern's work has very little to do with Ireland's modern conditions. In fact, McGahern has been accused of being indifferent to Ireland's modernisation. Such an accusation, however, is predicated on the linear temporality and the myth of progress. My project seeks to re-address this presumption by complicating the dichotomizing traditional/modern figure. Drawing from postcolonial and Marxist theories on modernity and temporality, my research argues that the strange timeless quality in McGahern's novels presents an unsynchronised rhythm that challenges progressive modernity. In thus doing, my project re-assesses McGahern's writing in a more theoretically-informed framework and re-evaluates the cultural significance of rural Ireland in temporal terms.

The author would like to express his gratitude to his supervisors, Professor Claire Connolly and Dr. Heather Laird, who have been most helpful and supportive of this project. Extended gratitude also goes to the Irish Research Council for their generous funding.

Daylight saving for the brain

James Cully

School of Applied Psychology, UCC

Learning never exhausts the mind. Leonardo Da Vinci

Learning throughout life

Our lives are comprised of our doings. We love, we lose, we learn and we forget, and throughout we are dependent on our brains to maintain a level of cognitive functioning (such as short and long term memory, attention to specific sensations and speaking and understanding language) that allows us to live our lives in the manner we want. If we lose this level of functioning we are bereft and vulnerable. Growing old is something to which every healthy human aspires. More and more people are reaching old-age; the ageing of the world's population is considered mankind's greatest achievement of the 20th century. It has also become one of the main health challenges in modern medicine; diseases associated with ageing, such as Alzheimer's disease (AD), have increased drastically in rate. One of the main consequences of developing AD is that your brain's functional capacity decreases. You forget more and more as it progresses, losing the ability to think, to plan, to function in a manner commensurate with your life to that point. You begin to become helpless. But research has found that we are not completely helpless, not always at the mercy of the absurd, relative to developing AD. How we live and what we do has an impact on the risk of developing AD.

Tom and Jerry

In a relatively large village in Cork, Ireland, two men in their early eighties passed away within a year of each other. Both men, Tom and Jerry, had spent all their lives in this village. Like the majority of the local community of their generation, once it was possible to leave school they went to work in the nearby factory. Tom and Jerry were friendly but rarely socialised much outside of work other than the odd staff night out. Tom was very active in his spare time, always engaged in some community building project or chairing a book club. He sang rather badly, but still took part in the amateur production of a number of plays during his 50's, organised by the local community centre. Two years ago he bought an iPad, feeling it necessary to remain in contact with his grandchildren. He had a smartphone for a year before this and so it proved relatively straightforward for him to master. Tom frequented a local cafe daily for breakfast, where he would read the Irish Times before rushing off to meet a friend for a walk, or attend a meeting in the local

Men's Shed group, a social activity group for men aged 50 or older. Jerry was always more reserved in his leisure activities. When he was employed he would normally head for a few drinks on a Thursday night, every other night he'd unwind at home in front of the television. He was strongly opinionated regarding the "new" technology that had become ubiquitous in society, insisting he was too old to bother learning something so alien to him. Jerry's trips to the pub began to lose their appeal over the last decade of his life; it became very difficult for him to keep track of the conversations, to remember the names of the people he spent many a long night conversing with. The world he once knew became a puzzle for Jerry and he was moved to a residential care unit on the outskirts of the village where he spent the last 4 years of his life.

When both men died they underwent autopsies as part of a study on ageing. Jerry was suffering AD at the time of his death, diagnosed as being in the middle-stage of the disease. His autopsy highlighted this; the neuropathological damage was consistent with his level of cognitive functioning. Tom was deemed cognitively healthy right up until the time of his death, performing slightly above the average level of performance for someone of his age. Yet, when an autopsy was performed it was found that the amount of neuropathological damage his brain had suffered was similar to that of Jerry's. How can this be explained?

Cognitive reserve

The cognitive reserve hypothesis postulates that individuals differ in the level of neuropathology they can endure before they show symptoms leading to a clinical diagnosis of AD. The hypothesis developed as a result of a series of startling discoveries that were made at the end of the 1980's. Studies such as that by Katzman and colleagues focused on autopsies of the brains of recently deceased older adults whose cognitive functioning had been measured during the final years of their lives. Certain brains showed levels of pathology that should have severely impacted participants' level of cognitive functioning and resulted in a clinical diagnosis of AD. Instead these individuals exhibited a level cognitive functioning equal to that of people of the same age who showed no signs of AD pathology upon their death. The authors termed this a "reserve", suggesting that it was called upon by the brain to compensate for damage.

There are two main models of cognitive reserve: the hardware model and the software model. The hardware model of cognitive reserve is a purely quantitative model of that suggests that people with bigger, heavier, brains are able to withstand higher levels of damage before a decrease in cognitive functioning is observed. This approach, known as Brain Reserve, assumes that there is a quantitative threshold, a limit of damage that can be incurred, before cognitive functioning is impacted. The software model of cognitive reserve is inherently different as it focuses on what is left of the brain and how it adapts to pathological changes to certain parts of the brain. The two main facets of the software model of cognitive reserve are Neural Reserve and Neural Compensation. Neural Reserve

explains the difference in levels of efficiency in brains, such that there is individual variation in levels of neuronal activation necessary for the completion of tasks. Higher Neural Reserve results in a higher capacity for activations for difficult tasks. Neural Compensation is the means by which the brain can complete tasks by recruiting different parts of the brain to complete a task that was initially done by a now-damaged brain area.

Improving cognitive reserve

Having a higher level of cognitive functioning is considered a proxy of a higher level of cognitive reserve. Cognitive functioning is measured by a variety of different tasks, and so improvement on these tasks is equated with a higher level of cognitive functioning. Research has identified a number of different variables that affect a person's level of cognitive functioning including education, occupation and the level of cognitive activities they can be engaged in as part of their lifestyle. There is a substantial body of cross-sectional evidence that highlights this strong association between having a high level of cognitive functioning and a decreased risk of developing AD. My research focuses on cognitive activities, and how they contribute to cognitive reserve. Cognitive activities as part of your lifestyle, such as reading, writing, doing jigsaws, playing crosswords, creating art, using an iPad and playing music are all examples of activities we engage in that may improve or sustain your level of cognitive functioning. I say may because as of yet there is not enough empirical evidence to make a case for or against a cognitively engaged lifestyle as a means of maintaining your cognitive functioning. There is a strong association between the two, but causality is an area of contention. One of the main aims of my research is to develop a programme of cognitive activities that target specific cognitive functions such as verbal fluency, short-term and long-term memory and then measure whether or not a person's cognitive functioning is improved by these activities.

Controlling the noise

The overarching theme of the research is to attempt to improve cognitive functioning through everyday activities that engage the mind. Recent research by Park et al. has found that taking up a novel activity that requires a detailed level of learning, such as digital photography or an iPad, can have a positive influence on our episodic memory. Episodic memory is a form of long term-memory that is autobiographical, concerned with personal experiences of the past, in essence our personal history. To carry out experiments that test the impact of certain activities on a person's cognitive functioning in a scientific manner requires that all factors which may influence a person's level of cognitive functioning be controlled for. For instance two elderly people given an iPad and tested on cognitive functioning at the outset and two months after may show very different changes in their level of cognitive functioning between the first and second test. There are many other variables that must be considered before changes in functioning are compared for both

people. One person may be suffering from depression and find it difficult to motivate themselves to practice this new task. Or they may have a low level of education and feel intimidated by the complicated nature of the task. Before the test of efficacy of everyday tasks it is imperative that all factors that can impact such improvements are known and measured during the experiments.

Study 1.1: The impact of perceptions of ageing on lifestyle

The first study in my PhD began in March. It focused on investigating the possible association between how middle/old aged people feel about the process of growing old and their cognitive lifestyle. This age-group was selected as it is an age period of transition, when we are nearing the end of our careers, nearing the beginning of old-age. How we feel about ageing, such as whether we think that we grow wiser with age or not, has been found to have an impact on many facets of a person's life. Research has found that people with a more negative perception of ageing in young and middle adulthood are more likely to suffer a decline in memory performance over the lifetime than those with a positive perception. The study comprised of a questionnaire that measured a number of different variables such as a person's perception of ageing, their level of cognitive activity and how serious or frivolous they believe certain activities, such as reading novels, can be. Questions pertaining to a person's primary occupation over the lifetime, what age they were, whether they are in receipt of certain medication, how long they spent in formal education were asked to compare these demographics. A scale that measured depression was also included in the questionnaire as previous research has found that depression can have an effect on how much time a person spends engaged in cognitive activities.

The results that emerged from Study 1.1 evidenced a strong association between a person's perception of ageing and their level of cognitive activity. People with a more positive perception of ageing were found to have a higher level of cognitive activity compared to those with a negative perception of ageing, when controlling for all other factors. This is the first time this association has been studied and so is an interesting finding. The next step in the research is to ascertain whether or not improving a person's perception of ageing in an experimental setting will mean that they spend more time engaged in a cognitively engaging task.

A battery of cognitive programmes

Once these experiments are complete I will begin the intervention programmes. The results of study 1.1 and 1.2 will be used to structure the interventions; because perception of ageing has been found to correlate with cognitive activity it will be controlled for in the interventions. Study 1.2 is an extension of Study 1.1 and will investigate if the results of Study 1.1 are replicated in an experimental setting. The interventions which I aim to run

are eclectic in terms of the type of activities. One planned intervention is a paired-reading style study where older adults would help children to read in a school setting, while another is to have participants engage in an intensive iPad learning course. Recent studies have shown improvements in skills specifically targeted by cognitive training. Unfortunately most of these studies have suffered from a lack of transference of the skills learned from these tests to everyday cognitive functioning. The aim of my research is to provide empirical evidence of cognitively engaging activities that improve general cognitive functioning. Recent research has found that novel and challenging cognitive activities have the potential to improve cognitive functioning not specifically targeted in older adults, and so I wish to emulate these studies while also accounting for a person's perception of ageing throughout the study. Achieving such results has the potential to ameliorate the current knowledge surrounding the association between AD and our everyday lives, thus moving us a step closer to understanding how best this disease can be delayed, or even prevented. Providing solid empirical data that shows that a varied and engaging cognitive lifestyle throughout middle and old age can sustain or even improve cognitive functioning may serve as an impetus for people to engage in such activities, a worthwhile pursuit.

Thanks to my supervisor, Dr. Mike Murphy, and to all the participants who have contributed to this research.

Photons in the machine

Shane Duggan

Department of Physics, UCC

“Don’t you see the starlight, starlight? Don’t you dream impossible things?” (Taylor Swift)

Power in your pocket

All our gadgets, mobile phones, music players, tablets, contain computer chips. These chips are powerful enough to store an abundance of knowledge. They are also small enough to allow the majority of our gadgets to fit in our pockets.

My work focuses on designing and building parts of circuits for these computer chips to simultaneously give them greater power and smaller size while using less energy.

Rise of photonics

At this moment you are in a warzone of tiny photon torpedoes. They are being fired in your pocket, on the screen in front of you. In actuality photons are blasting your eyes, because photons are just particles of light! We communicate with photons/light all the time. As you read this your eyes are receiving photons and your brain is processing the information.

This appears quite a complicated process, your mind has to decide what is text and what is background, and from there piece each letter together and assign the letter with a sound, and then combine all these letters together. Imagine how our brains do that. Can we build something which does the same? Yes, a computer of some kind.

Think of the most basic communication we can give: Yes or No. There is an entire branch of mathematics dedicated to these two answers and it was first introduced by George Boole after whom this Journal is named. This Boolean Algebra gives us the tools to break down the information on this page into a collection of Yes’s and No’s in a certain sequence, Figure 1.

And now this is where photons come back in. We need to send our information from one place to another, and we want to do it fast. We could use electricity through a wire. But is there something faster? We can see lightning hit the ground, so that means light travels to our eyes before the lightning travels to Earth. This shows that light is faster than electricity. And all we can do is turn electricity on and off, giving us options for Yes and No. But in fact we can turn different colour lights on, and we can turn it on “tilted” (polarised)

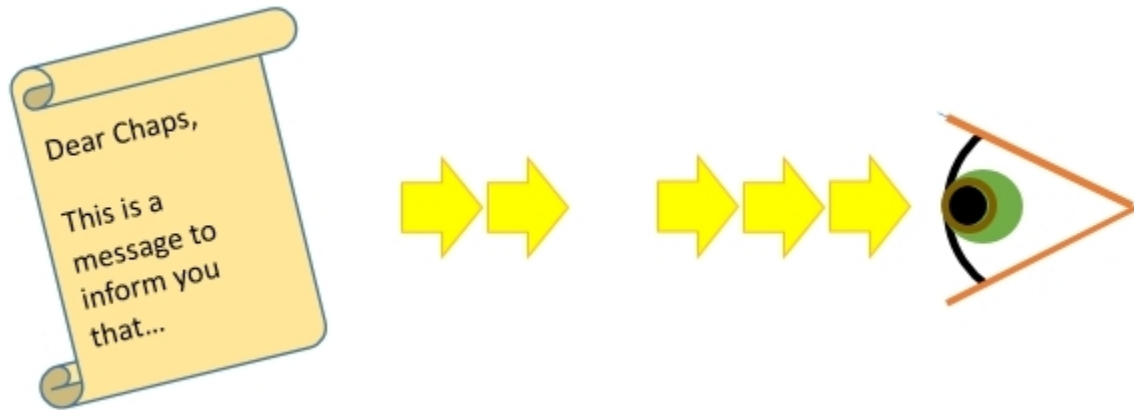

Figure 1: Information can be broken down into a series of Yes's and No's (on and off) signals to make transmission easier, and the original information is rebuilt at the receiver. This is possible using Boolean Algebra. Source: Author.

in different directions, so we can have more options than just Yes and No; now we can say more. We don't talk to each other in one word sentences (unless we are in a bad mood) because it's an inefficient way of transferring information quickly. Our technology turns to the field of light and photons, called photonics, because it increases our vocabulary and allows us to communicate more and faster.

Light communication

We send information to each other using light all the time, a classic example being traffic signals. We can even communicate with Boolean Algebra; by using Morse Code a person across a valley can flash a torch to tell their comrade something immediately, rather than having to run close enough to shout. Within circuits one part has to communicate with another part or else it can't do anything. The circuit talks to itself much like the person flashing the torch. In a circuit the torch used is a laser, and the laser is used because it is powerful and focused in a direction. Otherwise the light would be too weak to make it across the circuit and would shine the wrong way. Like the torch-wielder there are two options: turn the laser on and off, or leave the laser on and block/unblock the light so that it appears to the receiver that the laser is turning on and off. The latter is faster: leave the laser on and block its laser-light.

So for speed we need a laser and a signal generator to block and unblock the light. Clearly if we have the laser and the signal generator separate, then they will take up more space than if they were somehow moulded into a single device. To make our computers smarter we need to pack more things into them, giving them more thinking power. Unless we can make things smaller, computers will have to become bigger as we put more in. Even if we didn't care about space, what about energy? Whenever we connect different parts together there are flaws (Figure 2). A chair made from separate planks of wood needs screws to

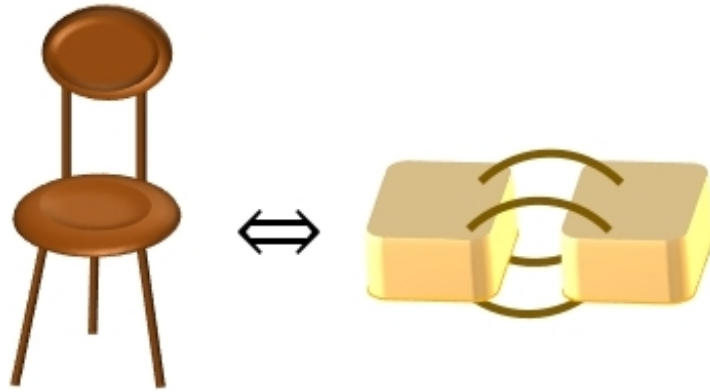

Figure 2: Comparison between a chair constructed from multiple planks of wood and a device made from separate pieces. Both of them have flaws and can be broken, however if they were carved from a single substance then they would be stronger. Source: Author

keep it together, whereas a chair carved from a single tree trunk is seamless. Whenever we shine light from one thing to another there are reflections at the joint between them so that light is lost and the signal is distorted. Try shining a light out your window; you'll see the reflection as the light travels from air to glass and won't be able to see outside clearly. To minimise space and prevent reflections it's preferable to have the laser and the signal generator seamlessly connected within a single crystal.

Laser farms

How does one put a laser and a signal generator into one crystal? Well, have you ever grown vegetables or plants? How about a laser?

Lasers are indeed grown! Particles are rained down and they pile up, bonding to each other, growing upwards like a tree. This forms a crystal with layers of different specific materials, and this is a laser. When electricity is passed through the crystal it releases light. The light bounces around in the crystal and grows stronger, coming out as a laser beam.

A signal generator is made the same way but with different layers. When electricity passes through it, it either lets the light pass through untouched or blocks it.

Currently the laser and signal generator are grown next to each other, joined side by side to form one crystal. This removes the need to have connections between each separate piece, and as it is one crystal, parts can't move and break. But growing them next to each other essentially amounts to the same as pushing them up against each other, so there is still the problem of the light reflecting as it crosses from the laser to the signal generator, wasting power.

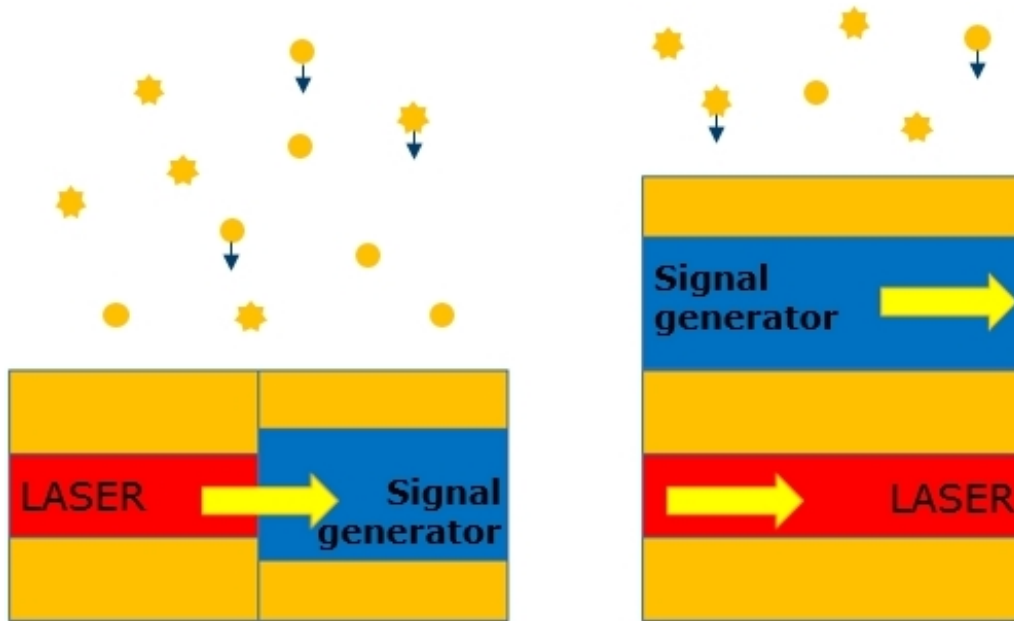

Figure 3: Particles rain down and bond together growing into crystals. The large arrows indicate the direction of light. Left) Current technique. The laser (red in the diagram) leads to a signal generator (blue in the diagram). The light shines through one into the other. Right) Proposed technique. The laser is below the signal generator. The light must travel vertically between the two sections. Source: Author

Objective

My aim is to develop a solution to the problems of reflections and power wastage while making everything as small as possible. Instead of growing the signal generator and the laser side-by-side, I will grow the signal generator on top of the laser, as illustrated in Figure 3. In this way they should be seamlessly bonded while being completely different at the same time; a bit like the hair on our heads, they are rather different, but they are bonded.

The art of light-bending

Now instead of the light shining in a straight line through the laser part of the crystal to the signal generator part, it needs to go from the laser at the bottom to the signal generator above it (Figure 3).

But if you shine light into a crystal it will just go where it wants, like if you shone light into a slab of glass. However we can make light bend from one part to another by shaping the crystal. Even Michelangelo couldn't sculpt these crystals into shape with a hammer and chisel because they are the size of a grain of sand! Instead the crystals have to be covered in a patterned mask and dunked into beakers of acid to dissolve the exposed sections. Or else tiny electrons can be shot at it to chip tiny pieces off, which is akin to using a machine gun to carve a statue.

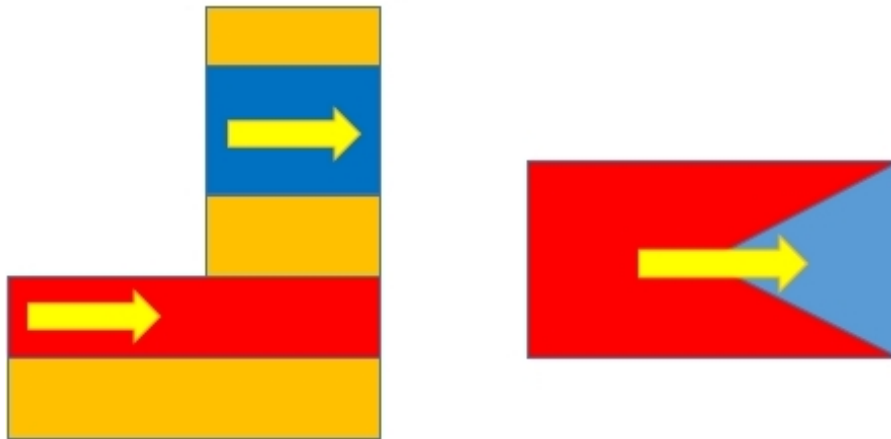

Figure 4: The arrows indicate the direction of light. Left) A side view of the grown crystal with the laser, red, on the bottom and the signal generator, blue, on top. Right) A top view of the crystal. The light travels from left to right in the laser, red, section, but once the signal generator, blue, section widens the light moves upward, all the while continuing to move from left to right. Source: Author

When part of the crystal is narrowed, it squeezes the light out of it, like a narrowing footpath forces us onto the road. And when part of the crystal is widened the light is sucked in, like a vacuum drawing in air.

I must shape the crystal to give light a path from one section to another (Figure 4). Then light can be shone into the lower section where it is in a laser and it gains strength and brightens, before being bended to an upper section where it is now in a signal generator and it is chopped on and off to encode information, like Morse Code with a torch.

Coming to a store near you!

In a crystal the size of a couple of grains of sand we can have multiple items, such as lasers and signal generators, and we can manoeuvre light, and with it information, between them. And we can put many of these crystals onto a circuit, and place these circuits in, for example, your phone to tell it what to do.

So in the future all your gadgets may be talking to themselves, and you, using the computer chips developed here!

Hyphenating Ireland and America: the contemporary construction of identity, film, and media in a hybrid space

Loretta Goff

School of English–Film Studies, UCC

The spectacle is not a collection of images; it is a social relation between people that is mediated by images. (Guy Debord, *The Society of the Spectacle*)

Introduction

In our increasingly globalized world evolving technologies have developed new networks for connection, primarily through the internet. These allow for the instantaneous spread of information, but also provide greater influence to the media and marketed ideas. Along with these developed technologies and networks, so too have the relationships between countries evolved. Ireland and America have long been connected, with millions of Irish emigrating to America through the years, contributing to its development as a nation and producing today's nearly forty million Irish-Americans. But what is the current relationship between the two countries and how connected to Ireland are generations removed Irish-Americans?

My research uses film, at both levels of production and representation, as a case study for the contemporary hyphenation of Ireland and America into a hybrid space largely constructed for profit, and the problematic performance of identity within this space. Film makes a particularly useful case study for this due to its nature as an early and lasting cultural export that is purposefully constructed, its ability to capture performance, and its popularity and influence. Not only do films reflect identity and international relationships, they also link with other media, including the internet, which contribute largely to the current relationship of Ireland and America. As it is this contemporary relationship and identity that I am interested in, my case study particularly looks at a broad base of Irish and 'Irish-themed' films produced from the early 1990s onward. The choice of this particular time-frame is significant as it marks the beginnings of both the Celtic Tiger and the popularization of the internet, both highly influential in developing this relationship to its current state.

The hyphen as a currency symbol

Hyphenated Americans have long been a topic of debate. On one side the hyphen is looked upon negatively, from Theodore Roosevelt's 1915 speech accusing those who were

hyphenated as being un-America and John Wayne's song "The Hyphen" which labels it as a "divisive line," to Louisiana Governor Bobby Jindal's recent calls for assimilation and condemnations of those choosing a hyphenated identity. On the other side are those who are proud of their heritage and don't feel it makes them less American to identify with it, such as Irish-American Congressman Joe Crowley who responded to Jindal by suggesting the Governor is suffering an identity crisis. To add to this debate, my argument is that the Irish-American identity has been recognized as a profitable one, and as such has now been developed into a market commodity, effectively replacing the hyphen between the two cultural identities with a currency symbol.



Figure 1: 1. Window display of Irish products for sale in specialty shop in Gettysburg, PA. Source: Loretta Goff

The media has largely shaped what Guy Debord would term a 'spectacle' of the identity, unifying society through commodity. Tourism campaigns such as "The Gathering," along with news stories, the selling of Irish products for the American market, and advertisements all contribute to this. One specific example from this combination of contributors was the presentation of a Certificate of Irish Heritage to actor Tom Cruise as part of "The Gathering" campaign. Though quite a few generations removed from Ireland, Cruise proudly touted his certificate in a number of interviews and it was widely reported by the media. The good news for anyone else wanting to mark their Irish-American identity in this way is that these certificates are available from the Irish Government to anyone of Irish descent for €45. Though embodying the literal selling of the identity, this does not necessarily make it negative, as it does bring a feeling of connection, belonging, and pride with it. However, it also demonstrates the economic forces—and tourism influences—at

work in the creation of an Irish-American identity.

Hyphenating Irish film

Setting clearly defined parameters for an Irish national cinema is a difficult task. Should it include any film with an Irish theme, only those filmed in Ireland, or those done by Irish directors? The fear of Hollywood dominance is not uncommon in national cinemas, and is particularly relevant to Irish cinema, dating back to its early days when Ireland's first film censor, James Montgomery, declared in 1924 that Los Angelesation was a greater danger to Ireland than Anglicization. Therefore, when there is American influence in an Irish film, be it through co-production, the use of stars, or marketing and distribution, this often results in the film being placed in a contested space outside of what is considered 'pure' national cinema, much like a hyphenated identity. The driving force behind this influence is, of course, usually economic in nature and it does impact the films to mixed results. For instance, the casting of Julia Roberts in *Michael Collins* (1996) was certainly a draw for American audiences and did not change the story or detract from its Irishness. However, her poor Irish accent makes it difficult for Irish audiences to take her character seriously. On the other hand, accent is not a problem if the American star is cast to play the role of an American character in an Irish film. Instead, this use of the star becomes key in driving the narrative as an explanation is needed for why the American is in Ireland. Recent films such as *The Guard* (2011) and *Standby* (2014) provide some examples of this. Meanwhile, a number of American films are driven by the fact that they are set in Ireland, with Americans travelling over, which similarly drives the narrative with an Irish theme. *The Matchmaker* (1997), *P.S I Love You* (2007), and *Leap Year* (2010) are among some of the more popular examples of this type of film, though there are quite a few others that follow the style. Ultimately, the linking of Ireland and America at a production level on a film will always filter down to its content in some way, allowing for analysis at a representational level.

Constructing identity and genre

There are certain key signifiers in the relationship between Ireland and America, and of the Irish-American identity that are built around stereotypes. These include the use of the Irish landscape, alcohol, and religion. When these tropes, along with the interaction of American and Irish characters, are looked at in terms of how they are specifically deployed within genre films in order to meet the conventions of that genre, they actually de-romanticise the Irish American relationship, even from within the 'spectacle.' To use landscape for a brief example, there are a number of romantic comedy films, including *Leap Year* (2010) wherein a female American travels to Ireland and, while she encounters a beautifully scenic landscape, she is also thrown off balance by this landscape, often falling in the mud and having inappropriate shoes such as heels that break. Meanwhile, in horror

films such as *Shrooms* (2007) the landscape is not only visually darker, it also produces hallucinogenic mushrooms that drive the fear in the film and wreak severe havoc with the American female lead's mental state. While the trope of the landscape is employed quite differently in each genre film, the American character is left unsettled because of it in both. By looking at my base of films in terms of how these tropes and identities are constructed within the particular conventions of genre, I am ultimately applying Rick Altman's semantics/syntax approach to film genre to my case study of the Irish-American identity in film. I consider the tropes of the identity as the semantics, or key elements comprising the films, and the conventions of the genre as the syntax, or the specific ways these pieces are arranged and used. Ultimately, though portrayed differently across genres of romantic-comedy, drama, crime and horror, when the Irish-American identity is depicted within and according to the construct of each genre the overall message is that in order to be happy the character must reject one cultural identity for the other. This message illuminates the fact that, overall, films take a conservative approach to the debate over hyphenation, ultimately portraying a singular, 'pure', identity as 'safer', despite profiting off of, and largely encouraging, an Irish American relationship.

Conclusion

Though genre films may initially appear to be no more than 'spectacle,' taking a deeper look at them reveals the nuances of the contemporary relationship between Ireland and America, and reveals the conservative approach they take in regards to the hyphenated Irish-American identity, calling for cultural assimilation. As Barry Keith Grant points out, "whether they are set in the past or in the future, on the mean streets of a contemporary New York or long ago in a galaxy far away, genre movies are always about the time and place in which they are made." Similarly, whether these films convey what they do because of economic influences and an Irish and American relationship at the production level, or they are just representing the complex contemporary relationship and identity the best way they see fit, these films are key to examining both.

My concentration on the hyphen in the Irish-American identity acts as a magnifying lens for examining the problematic construction of this identity, with ideology and mediation at the core of its formation. The use of film to explore this highlights the fact that identity is a performance, with those seen on screen often being exaggerated displays of daily individual identity performance. In today's digital world where identity performance is heightened and easily captured across multiple mediums, the impact of my research which explores not only the performance, but, importantly, the economic and ideological roots that shape and feed this performance, is increasingly relevant to understanding the contemporary Irish-American identity and relationship between Ireland and America.

With gratitude to my supervisor Dr. Barry Monahan and CACSSS for the generous funding.

What do the translator and the grocery shopper have in common? Well, everything!

H. Pierre Hsieh

School of History , UCC

Introduction

What would be the first thing that comes to your mind if I told you I was a translator? Chances are it would be “mediator”, “negotiator” or “communicator” if you have had prior dealings with the academic field of translation studies, or it would be “copycat”, “impersonator”, “plagiarist” or “cribber” if you have never even heard of translation studies. More specifically, what if I told you I was a legal translator? Chances are it would be more or less the same thing, only this time around you would probably be grappling with what to make of the term legal (Well, does it mean “concerning the law in general” or does it mean “legitimate”?) All this indicates the low prestige that is accorded to works of translation and the disrespect for translators that the lay public has. How did it come to this, and does it have to be this way? The way I see it, this is the case because scientifically rigorous research on translation as a social phenomenon and human activity has not been pursued satisfactorily, and hence, translation studies must now carry on in a systematic and scientific way.

Translation Theory

What is translation theory and why does translation even need a theory at all? Should it all not be rather straightforward? Paradoxically, at the same time, many translators wonder why translators and their work have rarely, if ever, been taken seriously. The truth is most people will have some dealings with translation at some point in their lives. Who can claim that they have never enjoyed a short story or a fairy tale—either on paper or on film—by a foreign author that had to be translated into their native language? Who has never played a video game that was imported and had to be translated and/or localized? And who has never travelled overseas and had to obey a sign that required the imagination of some translator? However, as it turns out, if a translation is terrible, then it is the translator that is to blame; if it appears successful, then it is the author—not the translator—that gets the credit. In other words, damned if you do and damned if you don't. Given how widespread, necessary and ubiquitous translation is, why the low prestige and the guilt associated with it?

The reasons may be many, but my simple answer to it is that translation has never earned due respect because it was never properly associated with people's everyday lives, and academia still has a long way to go. More to the point, true, laypeople, uninitiated as they are, may have the wrong idea about translators by considering them little more than someone reciting a text that they themselves have hardly made any contribution to, but translation theorists, who have seriously devoted themselves to the true nature of translation for decades, must share the blame. Please do not get me wrong; by no means am I suggesting that translation theorists like James Holmes, Anthony Pym and Maria Tymoczko have achieved nothing; it goes without saying that they have made great contribution to human knowledge by coming up with various ways of describing the translation phenomenon, and, yet, the thing is, it appears to me that their efforts may not have gone far enough. Indeed, thanks to the discipline-wide tacit understanding that translation studies is inherently interdisciplinary as it deals with a phenomenon that requires the expertise from a myriad of established disciplines, translation theorists have taken advantage of sociological methodology—and quite successfully for that matter—and have thereby benefited greatly from it. This is promising, but much as I agree that translation must be studied as a social activity in the context of sociology, sociology alone will probably not be sufficient to make translation resonate with the lay public—and with good reason.

Our world is dynamic and ever-changing, with robust changes occurring every day that attract the attention of social scientists. While sociologists look at human behaviour their own way, economists approach it in a totally different light, usually by identifying values that matter and assigning each of them a numeric value (quantification). While, to a great extent, interviewing and fieldwork constitute the cornerstone of sociology, economics deals with quantified values presented in the form of equations, matrices and mathematical expressions. Admittedly, each comes with its unique strengths and hard-to-overcome weaknesses.

At the heart of the argument is the process of theory construction—translation theory to be exact. Translation studies is, by definition, the academic scholarship that is responsible for the development of translation theories. While the word translation itself rarely conjures up a romantic image among the lay public, which tends to regard the translator as nothing but a “copycat” or, worse yet, a traitor — as the witty and frivolous saying *Traduttore, traditore*, (literally, “the translator, the traitor”) goes there is actually more to it than meets the eye. People often inadvertently fail to realize that the translator is as much a human being made of flesh and blood as anyone else and that translation is no less a human activity than anything else. More specifically, human beings, emulative and gregarious as they are, are social creatures who live and survive in societies that impose norms on them whether they like it or not. This is probably inevitable for collective life to be possible and also for “the greater good”. At the same time, they are economic creatures in that they are rational and self-interested and have their agendas to pursue; they know what is in their best interest and how to achieve it, despite their occasional ignorance of the related risks

their action entails and the potential impact it has on others (externalities). This is, as a matter of fact, a fundamental aspect of human nature that has served as the driving force behind human civilization since time immemorial.

On this view, from the sociological perspective, the translator is a social being who must, either consciously or subconsciously, comply with all prevalent social norms (and by “norms” I mean everything from morals to bylaws and regulations) of the day, and so, as a quick example, if the term queer (to denote “homosexual”) is not socially acceptable in that it may evoke negative sentiments among the target readership, or worse yet, allure the watchful eyes of the censor, then it should be best avoided by the translator. This approach does have its merits, except that it only captures one dimension of translation by viewing it as a social phenomenon. On the other hand, translation does have an economic dimension to it, and in this context, the economist may prefer to approach it from an economic perspective by viewing it as an economic activity involving a host of quantifiable values. Arguably, these two conspicuously unrelated perspectives can and will work hand-in-hand towards a fuller and more complete picture of translation.

In the eyes of the economist, every individual is both rational and self-interested insofar as they are acting within the limits of the information available to them. They are self-interested (or self-serving or selfish, as some prefer in the sense that they are aware of what is optimal for them—and for them only, and they are rational in that they understand how to achieve that interest. Thus, for the sake of illustration, the consumer and grocery shopper will take only their own interest into consideration when struggling to make up their mind what consumer product to buy (Is it going to be apples, carrots or onions on the dinner table?) and where to buy it (Say, Tesco, Aldi or Lidl, anyone?) based on the information available to them (How long will it take to get there? And will the check-out queue likely be long?). While generating the optimal choice, will they consider what someone else would like to have for dinner? Probably not. And will they do what they think is right for themselves? Yes, of course. And so is there a subtle, hidden and unspoken rule or logic to it? Definitely. And would it be possible to approach and describe that logic that is so intangible and yet so powerful nonetheless descriptively and quantitatively? Absolutely!

The same thing goes for translation. The translator, forced to make repeated choices and decisions throughout the lengthy process of rendering terms, phrases, sentences and other lexical units into the target language, is expected to strike a fine balance between making the original text accessible to a new audience and maintaining its essential foreignness and originality, as well as a delicate balance amongst a wide range of mutually conflicting values. For instance, when confronted with the phrase *Le Québec et le Canada*, should the translator just translate it literally as “Quebec and Canada” or, perhaps out of some political finesse or in deference to unspeakable peer pressure, paraphrase it as “Quebec and the rest of Canada”? Whichever version the translator eventually goes with, the pos-

sible values behind their choice could have been personal ideology, profitability, physical length, typesetting, rhythm, personal preference, editor's preference, and consistency, just to name a few, each of which may be subject to quantification, while, in the meantime, the potential costs would include risk of offending the target readership, risk of unfaithfulness to the author as well as (possibly) censorship, all of which, again, could avail of quantification. And how is this any different from the math and arithmetic that the grocery shopper has to go through?

Conclusion

Thus, I firmly believe that there is little difference between the translator and the consumer and shopper. The truth is, when a consumer purchases groceries, they understand what they need (interests) and what their budget is (resources), and on top of that they are aware how to achieve what they want (rationality). Different supermarkets may have dissimilar prices and merchandises, but they also have different store hours and distinct locations (information). There are always hidden costs (overheads) involved, as there may be potential side effects (externalities) entailed, which will then lead to the optimal decision (maximum profit). All these factors, which are to be taken into consideration and then subjected to calculation, are comparable to what the translator has to deal with in their line of duty. It may not seem obvious *prima facie*, but translators are usually confronted with an overwhelmingly large amount of factors ranging from what saves time, what wins the audience's attention, what pleases the publisher, and what will get past the censors... when making up their mind how to render a phrase from the source language into another language. Seen in this light, all human activity is economic in nature, be it voting in an election, alcohol consumption, white-collar crime or translation. As long as translation is considered a human activity, its description should utilize economic analysis, and human experiences derived from consumer behaviour will serve as a powerful and useful example on this score. Nothing may sound more straightforward, but few in translation studies realize that translation, as a human activity, can have something so economic going for it.

This is truly a shame, for if translation theorists and translators themselves all noticed that, not only would it help theorists ascertain the true nature of translation, translation would also appear closer and more relevant to people's bread and butter. This will unquestionably give the status of professional translators a boost, which will, in turn, urge more competent bilingual and multilingual individuals to enter the translation industry and provide more translation works for the general readership at large.

As two human activities, translation and consumption share a host of common traits; this includes, among others, rationality, self-interestedness, profit maximization and ethics. First off, the translator, just like the grocery shopper, is self-interested in the sense that they pay attention to nothing but what they can get out of it, and even if they appear altruistic

from time to time, they are eventually doing it to their advantage. In pursuing their goal, the translator makes choices that produce benefits and gains for themselves, serving their own interest. Second of all, the translator, just like the grocery shopper, is rational in the sense that he understands how to achieve his very self-serving and egocentric goals. When handling a domain-specific term, they may have to consult an expert for advice, a dictionary or a terminology bank, just as a consumer would go bargain hunting for the goods and services and ask around for the perfect price. Thirdly, the translator is a profit maximizer in the sense that they will always work with a built-in “calculator” that does the math for them by adding up all the pros (monetary gain, reputation, fame and pecuniary interest. . .) and deducting all the cons (risks, censorship, time and other forms of monetary expenses. . .). Last but not least, just as there are ethics involved in sales and purchases (Must the seller disclose every minor detail about the merchandise to the buyer?), there will always be baffling ethical issues involved in translation as to, *inter alia*, how faithful the translator should be *vis-à-vis* the author, if and how much the translation should be allowed to deviate from the original, and whether it is acceptable to add one’s own remarks and comments to a translation.

See how simple it all is! The translator and the grocery shopper have everything in common, because they are both simply you and me—people who are trying to make tough choices and hard decisions. At the end of the day, no matter what industry we find ourselves in, we are all trying to make the best choices for ourselves with whatever limited resources and information available to us. Since economics is good at explaining all this, it will, alongside sociology, have a great deal to offer translation studies, and as such, it will undoubtedly make translators more respectable and translated works more approachable to the general public, which will, in turn, remind people to start affording translators and their works the awe and respect they deserve.

Legal textbooks — the reflection of socio-legal reality

Blazej Kaucz

Department of Sociology, UCC

Introduction

In my research, I am attempting to employ a novel approach to legal textbooks, by treating them as the source and effects of social change. Legal textbooks are used on a daily basis by students, academics, and the legal profession—lawyers, solicitors, barristers, and also by judges. For a number of reasons, the last group of professionals is the scope and range of my research.

The judicial decision making process

Judges are considered to be highly esteemed and important representatives of the legal profession. Their decisions influence—and are being influenced by—directly and indirectly, legal textbooks and their content. Law textbooks are the source of inspiration, and might be considered as a repository of legal knowledge. Legal textbooks could also be considered as one of many platforms for professionals to discuss and engage, to a certain degree, matters which are of importance to these professionals. The textbooks might be employed for the purpose of advancement of knowledge, and might play a significant role in the unification or separation of views in a certain field in question.

In this research, I am aiming to capture change, caused, or influenced, by the content of the most significant textbooks, representing certain branches of law. I have decided to choose four distinct divisions of law for the purpose of my study, namely: constitutional law, family law, criminal law and corporate law. Every branch of law has its own specificity, and I would hope to capture each during the course of my research.

In addition, each one of these branches of law will be represented in my research by one of the most prominent legal textbook in that field; the textbook which most practitioners in that specific field of law would consider to be a corner stone for that field, and a point of consultation when in need.

In order to shed more light on the captured influence, I am going to compare the specific textbooks—and their content—published in two countries, Poland and Ireland, due to similarities and differences in the types of the legal and political systems historically

employed by both of these countries; and how these are reflected in a judicial decision-making process.

These two countries are situated in two distinct legal traditions. In short, I have selected Poland for its continental and mostly statutory law. Ireland was selected for its unique common law system. The two countries share many features in terms of the way in which the statutory laws are being enacted, specifically, in both cases, by a bicameral parliament with a president as the head of state. Moreover, the research will employ a number of methods of reading legal discourse, present and well established in the disciplines which are part of the research (law, sociology and socio-legal studies). In addition, aforementioned research addresses the issues of how to combine these methods in one coherent method.

So, why is this important?

The law is a social structure or instrument affecting us, as members of a society, and, also, it is imposed by the same society (and by its members) on every one of us, the same members of that society. But then again it is an abstract and intangible concept, and it is not so simple to say that laws came to be in this or that way.

Furthermore, there are a large number of decisions being made every year by judges. Some are of great importance to the entire legal systems where a decision is made on a point of law and of importance to the specific stakeholders; although, the majority of these decisions are mundane, everyday cases and issues that the judges will have to face.

Law and language

Law and language are at the heart of my research; these are intertwined and essential elements of the inquiry which I am making. One of the aims of my research is to gain a greater understanding of the law and its language. This is being encapsulated by the concept of bilinguism, the term infrequently used in relation to an adequate knowledge, expertise and understanding of the specific legal and social order; and which will have to be embedded in, and supported by, the knowledge of the language used in that specific jurisdiction.

Conclusion

This research is a journey, in which I am trying to make sense of all of that which is involved in producing and using legal textbooks. Of key importance to my research is, who is influencing the legal system, and especially, the judicial decision making process, and how and why? I am hoping that the findings of my research will enrich our understanding of the processes described above.

Blazej Kaucz is a PhD student in the Department of Sociology, and working under the supervision of Professor Colin Sumner, to whom the author is eternally grateful for the continuous support, advice, and for the motivation to try to achieve more with each subsequent step.

The internet is not limitless

Niamh Kavanagh

Department of Physics, UCC

“I travel light. But not at the same speed.” (Jarod Kintz)

Consider this: you’re moving to a new country and you have to fit everything into a single suitcase. Your airline is being very stringent in this situation and you don’t want to give them the satisfaction of paying more fees! So, what can you do? You could spend weeks trying to fit it all in, trying different ways to organise everything, but sometimes there’s just too much stuff. Well, why not try a completely new, lighter, bigger suitcase? In my research, I try to think the same way about optical fibres.

What’s this all about?

The basis of my PhD is the development of high-capacity optical communications systems based on new types of optical fibres. In optical communications, digital information is transmitted via optical fibres. Similar to our nervous system, which sends information to different parts of our body via electrical pulses, optical fibres transmit information throughout the world using pulses of light. These fibres are threaded across our whole planet; beneath our feet and under our oceans; connecting cities, countries and continents.

Optical fibres are thin glass fibres, only the thickness of a human hair. If you shine light into the fibre it bounces off the walls and travels along, similar to a ping pong ball down a pipe, as you can see Figure 1.

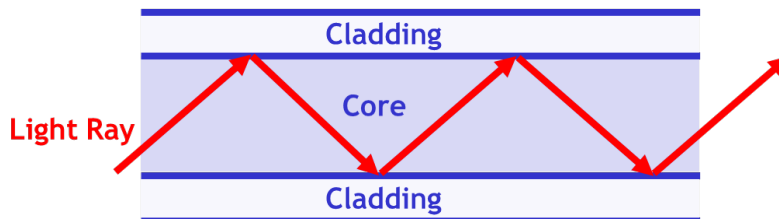

Figure 1: Light travelling in an optical fibre. The fibre is made of glass materials of different densities. The cladding surrounds the core, which is made of denser glass. Source: Niamh Kavanagh

The light signal, provided by a laser, can be encoded with digital information using modulation. Modulation is the addition of information to a light wave by varying properties of the waveform. A simple example of modulation is shown in Figure 2: turning the laser light on to represent binary 1 and off to represent binary 0, utilising Boolean logic similar to Morse code. Digital information has now been translated into pulses of light which

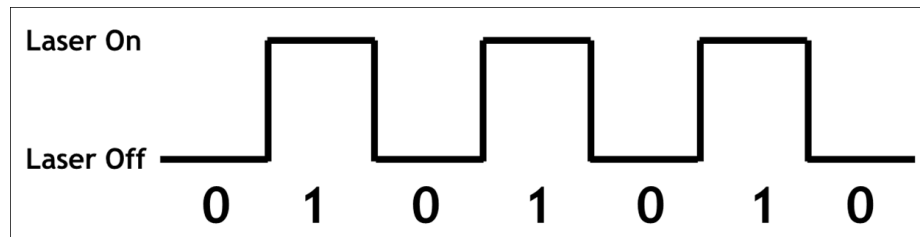

Figure 2: Modulation. Digital information consists of patterns of bits (1's and 0's). These bits can be represented by pulses of light. Source: Niamh Kavanagh.

travel down the fibre at very fast speeds. We can also send several data signals down a single optical fibre at the same time by using light of different colours (i.e. different wavelengths) to carry different data. In this way, optical fibres can carry much more information than copper cables of similar diameter. For example, a network using modern copper lines can carry 3000 telephone calls all at once, while a similar system using fibre optics can carry over 31 000!

Sounds great, what's the problem?

In today's world, we need to communicate more information than ever before. The internet is not limitless; internet traffic is increasing year-on-year and there is only so much that our current communications systems can handle. Many people now own a mobile phone, tablet, laptop and TV that can all connect to the internet and stream high-quality videos. American multinational technology company, Cisco, predicts that about 50 billion devices will be connected by 2020. Others think the figure could actually be as high as 75 billion - that's 10 times the UN estimate for world population! The "internet of things" is ever-increasing; according to reports, there are 200 unique consumer devices that could be connected to the internet that have not yet done so. Soon, everything from your car to your kettle will send information back and forth over the internet to make sure you have a cup of tea waiting for you when you get home from work! All this information will travel over optical fibres at some point in its transmission.

This increasing use of mobile networks and remote devices is creating a strain on current communication networks and could lead to a global "capacity crunch" in the not-so-distant future. When we talk about capacity we're actually talking about speed, or the amount of data you can transfer in a given time. Less capacity means slower speeds. So, this capacity crunch, if allowed to happen, could seriously impact the internet's future growth meaning slower internet, Skype calls losing connection and more time spent sitting at your laptop watching that little buffering symbol whirl round while you wait for your video to load.

There are several ways to try to combat this capacity crunch. One is to try advanced modulation methods; so instead of just varying the intensity of the light by turning it on and off, you can manipulate other aspects of the light such as its frequency or phase. However, these methods are getting more and more computationally demanding.

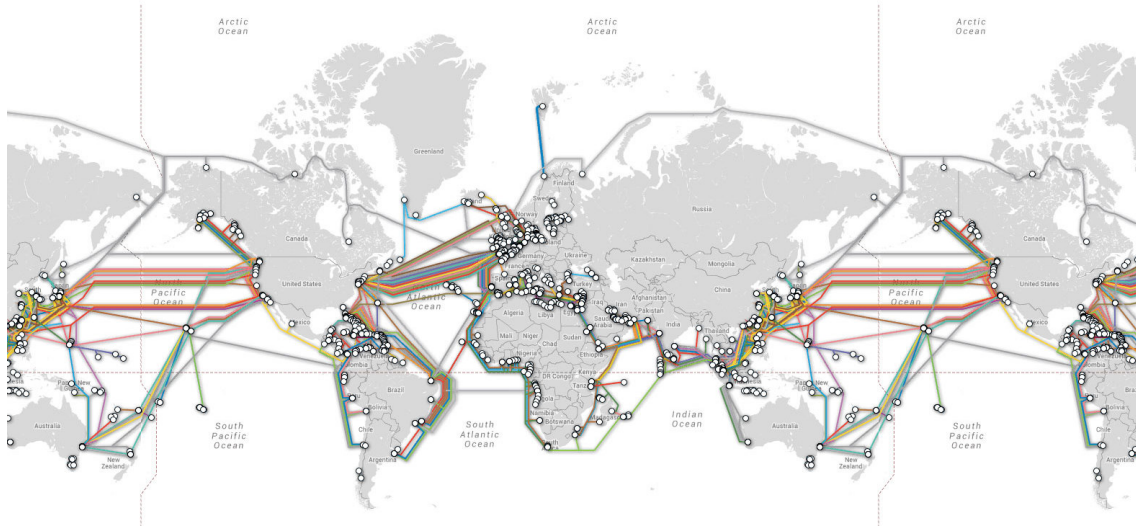

Figure 3: Submarine cable map. This map shows the optical fibre connections under our oceans and seas. These cables form the backbone of our global communications network. Source: Used with permission from TeleGeography:

A second technique is to maximise the use of available bandwidth. Bandwidth refers to the amount of light signals that you can send through the fibre simultaneously (with sufficiently low loss). More bandwidth means you can send more signals and therefore more information. Think of it like increasing the number of traffic lanes on a motorway; more lanes means more traffic can flow. However, we are reaching the maximum bandwidth capability of solid-core fibres.

For long-distance communications, such as transatlantic connections and those shown in Figure 3, the issue of losses becomes very important. As the light signal travels down the fibre it will always incur losses. By gradually leaking out through the fibre walls with each reflection, the signal will fade over distance. To overcome the losses you could increase the power of the signal. However, for high powers, the light signal will begin to interact with the glass of the fibre in unpredictable ways and this can corrupt the information being transmitted.

When the power of the signal is reduced as it travels along, the probability of errors is increased; some 1's will be mistaken for 0's and vice versa. This effect is similar to listening to a radio; at low volume it's difficult to distinguish individual words, so, in order to hear it better you turn up the volume, that is, you increase the power of the sound signal. The same is true for a light signal travelling in a fibre. After a certain distance the signal will need to be amplified in order to provide it with sufficient power to reach its destination and remain clearly distinguishable. The less we have to amplify the signal, the better.

Therefore it is desirable to make sure the losses in the fibres are as low as possible. Solid-core fibres have the lowest loss in the wavelength region of 1.5 micro-meters and, for decades, this wavelength has been the main focus of the optical communications industry.



Figure 4: Cross section of solid-core fibre (left): a core of glass is surrounded by a cladding of less dense glass — the light travels in the glass core by bouncing off the core walls; Cross section of hollow-core fibre (right): a core of air is surrounded by a honeycomb structure of glass — the light travels in air by reflecting off the walls in the structure surrounding the core. Source: Niamh Kavanagh.

The current record for lowest loss is around 0.2 dB/km. For every kilometre the light travels, it loses 0.2 dB of power. As an example, this means that after 50km, 10% of the power remains.

We have pushed conventional optical fibres to the limit. We've tried several ways to try and pack it all in (advanced modulation, increasing bandwidth, higher powers), but these methods are becoming more and more complex. New solutions are needed to meet future demands.

So, what's my solution? A new suitcase!

Instead of trying different ways to pack the information in, let's try a different way of carrying the information! Hollow-Core Photonic Bandgap Fibres (HC-PBGF) may be our answer. These fibres are structured similarly to a drinking straw. A glass tube surrounds a core of air, which means that these fibres guide light through air, rather than glass as before. For example, the difference between solid-core glass fibres and these new hollow-core ones is like running in water versus running outside on a track; the light is no longer impeded by travelling through the glass. The difference in the structures of the two types of fibre is illustrated in Figure 4 (left and right).

Hollow-core fibres have several promising advantages over solid-core fibres. They are predicted to achieve losses as low as 0.1 dB/km, which means that 10% of the power remains after 100 km, i.e., double the previous distance of 50 km. This means less amplifiers will be needed for the same distance. Even better, it is thought that these hollow-core fibres are capable of increasing capacity by 10 to 100 times more than that of solid-core fibres! These fibres have three times more bandwidth and since the light signal now interacts with less material as it travels along, we can launch signals into the fibre that are 1000 times more powerful than before. They can carry much more information, farther and faster than we've ever seen.

But what does that mean to us, the users? The total capacity refers to the number of bits (or 1's and 0's) transmitted per second. Let's assume that the total capacity of solid-core fibre is about 10 terabits (that's 1 000 000 000 000 bits) per second and that this supports a hundred thousand users (which is roughly the population of Cork city). If hollow-core

fibres can provide a ten-fold increase in capacity this would mean that one million people, that is the whole of Munster, could then be supported by this communications system!

However, as always, there is a catch. The minimum loss of these new hollow-core fibres is at a longer wavelength of 2 micro-meters (rather than 1.5 micro-meters for solid-core fibres) and this means we need to develop components operable in this new wavelength region.

Now, when talking about components, you can think of an optical communications system like a tin can telephone. You have a transmitter, a receiver and a transmission medium. When my brother and I were little we used to have one of these between our bedrooms. We tried out different tin cans and found the best string, which turned out to be the twine that my Dad used to hold up his tomato plants in the garden. He wasn't too happy when we "borrowed it" for our telephone! But my point is, everything was optimised for our little telephone system. The same is true for optical communications, everything is optimised for solid-core fibres. However, as researchers, we have to ask ourselves, is this really the best system?

What am I doing to help?

The move from solid-core to hollow-core fibres is, unfortunately, not as simple as switching suitcases. Hence, the goal of my PhD research is to optimise this new communication system operating at 2 micro-meters, from transmitter to receiver. This includes new lasers, amplifiers, modulators, detectors, filters and much more. The aim of my PhD is to show that optical communications at 2 micro-meters is possible, with the same performance as current 1.5 micro-meter systems. This is important because, in this way, the expensive electronics associated with optical communications system can remain the same. By upgrading only the optical-side of the system, we can enable much greater bandwidth, lower losses and higher powers, thus significantly increasing the overall capacity by 10 to 100 times.

Conclusion

So, think back to that suitcase of yours. It has to carry a rather funny collection of travel items — emails, HD videos, Skype calls, and all manner of social media posts. With the growing global demand for faster and larger data transfer, a "capacity crunch" is looming large. New, radical ways of thinking are needed to meet future demands. To me, hollow-core fibres look like a promising possibility. These fibres offer significant improvements over standard solid-core fibres and could increase the overall capacity by up to 100 times! If we can show that optical communications at 2 micro-meters is a viable alternative to 1.5 micro-meter systems, while maintaining the same electronic setup, I think we'll have found our new bigger, lighter and better suitcase for next-generation optical communications!

I wish to express my sincere thanks to my supervisor Dr. Fatima Gunning for her support, guidance and motivation. I am also grateful to my family and friends (shout-out to Mike, Brian, Shane and Jessie) for their proof-reading, reassurance and constant encouragement. I would like to acknowledge the Irish Research Council (IRC) as the funding body for my research, as well as the EU FP7 IP project MODEGAP (258033), SFI projects 12/RC/2276 (IPIC) and 13/CDA/2103. Thanks also to the staff of the Department of Physics (UCC) and the Photonics Systems Group (Tyndall National Institute).

Holy humour: Vernacular saints' lives in England, 900 — 1300

Niamh Kehoe

School of English, UCC

Introduction

A modern audience, seeking literary entertainment in the form of adventure, gruesome violence and humorous word-play, would be unlikely to turn to saints' lives – particularly those written a thousand years ago. Medieval religious texts, and the people who wrote and copied them, are not usually associated with levity: rather, they are generally perceived as pious, holy, and serious — as are the homiletic and didactic works which they wrote. Is it so improbable, however, that holy texts conveying a serious meaning are entirely different creatures to texts which entertain (such as the Exeter Book *Riddles*)? The two genres are not necessarily mutually exclusive. While society today may find it strange, or even bizarre, to equate religious texts with humour, this coupling of seemingly incongruous qualities was not unusual for medieval societies, where the line between sacred and profane was often blurred. This can be seen in medieval texts themselves, where manuscripts of a religious nature are often decorated with obscene or grotesque images: the Luttrell Psalter and the Gorleston Psalter are two examples, both of which were produced in England in the 14th century.

While previous critical studies have explored the use of humour within various genres of medieval literature, including saints' lives, my work aims to identify and trace the development of the use of literary humour within a specific context: violent episodes of saints' lives, written in England from the late-900s up to 1300. In doing so, this study investigates whether humour was used to clarify aspects of the Christian doctrine associated with the martyrdoms of saints. The late 900s to 1300 was a period of great social change in England yet of continuity in the types of saints' lives copied and circulated. Focusing on a genre popular throughout the Middle Ages allows me to trace the development of humour in saints' lives from pre- to post-Conquest England, establishing literary continuities in translation. This permits me to assess whether the acknowledged entertaining qualities of later medieval saints' lives had any precedent in earlier Old English lives. As the form of humour in violent episodes differs according to the gender of the saint, I examine both male and female lives, enabling me to determine how the saints' gender affected the representation of humour within violent episodes, and how audiences responded to these episodes in medieval societies.

This approach to early medieval saints' lives will expand our knowledge of the societies that wrote and circulated these texts, challenging the perception that early medieval society was humourless, and altering our understanding of the medieval audiences for whose benefit these texts were translated from Latin into vernacular English.

Medieval mischief?

Much work has been written regarding humour and medieval works (perhaps the most notable being the Old English *Riddles*, and in Middle English literature Chaucer's *The Canterbury Tales*), and they have yielded varied results. Heroic texts, such as *Beowulf* and *The Battle of Maldon*, have been the subject of much critical and scholarly consideration, in which word-play and symbolic laughter have figured largely in the identification of humour. Much of this Old English humour has been labelled "grim" or "sombre" however, and this perception has stretched somewhat to encompass not only heroic texts but also texts of a religious nature.

The Exeter Book *Riddles* nonetheless points to a more playful sense of humour (particularly the obscene riddles), and we do have surviving evidence that life in a monastic setting may not have been as "sombre" as we often presume it was — not least that it would have been religious clergy who copied the sexual riddles. Critic Martha Bayless has pointed to admonitions spanning from the 8th to the 10th century, which rebuke members of the clergy and monastery alike for their behaviour: for their laughter, jokes, drunkenness, and feasting. Despite these frequent condemnations, the rate at which they recurred suggests the continuation of such behaviour, implying that medieval religious life may not have been as "sombre" as we picture it today.

Literary critic Mikhail Bakhtin's theory of "high" and "low" cultures has also been questioned. Rather than humour and revelry being accepted as having exclusively destabilising qualities and therefore being associated with disorder and ultimately with the "low" members of society (which consequently renders the upper echelons of society, such as members of religious orders, serious), it has now been acknowledged that humour and laughter are (and were) fluid across social groups. Humour cannot be assigned to one community of people.

Yet what of didactic and homiletic works? Would the writers of such texts have wilfully incorporated humour? Examples of literary humour within religious works should not be regarded as undermining their purpose — as we have seen humour should not be associated exclusively with being "destabilising". The use of humour to teach was by no means unusual, or unheard of; indeed it was a tradition carried down from Antiquity, and while its form may have altered with the growing influence of the Church, humour was still very much present in religious works. Concerning saints' lives in particular, historian Ernst Curtius in 1953 noted that audiences of such lives would have *expected* humour.

Saints in society

Certainly, saints' lives are not such an unusual place to look for humour as one might think. Saints themselves played a much more prominent role in medieval society than we would attribute to them today. New candidates for sainthood were constantly being put forward, with churches competing to promote their favoured saint — theft of relics to achieve this was not uncommon. Saints also had a much more physical, as well as spiritual presence; shrines to particular saints often held a relic of the saint that people could touch, or view. It could even be said that medieval saints were the equivalent of modern-day celebrities, or akin to modern day super-heroes, due to the miracles they performed.

Saints were acknowledged as being higher beings: they were not mortal, which was confirmed during their torture scenes, as they were able to withstand instances of horrendous torture without (for the most part) feeling any pain or being physically blemished. Their torture, and (in the case of martyrs) eventual death was welcomed, as it was a necessary step towards their heavenly union with Christ.

Vernacular saints' lives, circulating in manuscript form, served a specific purpose in medieval society: to be read aloud to educate the laity in matters of Christian doctrine, many of whom would not have had access to Latin learning. They functioned as edifying texts, and the saints themselves acted as models for Christian virtue, to further strengthen the readers' or listeners' faith. Simply because these texts primarily functioned as edifying texts however, it does not necessarily follow that their lives, which were so often embellished with episodes of violence and miraculous events, were void of elements of humour. Indeed humour (often occurring within episodes of violence) may have served an integral role within these lives — to maintain audience attention, and as an effective means to direct interpretation of the narrative. By directing audience interpretation, I mean to say that humour may have been used to guide the audience away from *worldly* or everyday interpretations of violence, encouraging them instead to understand the religious significance of the saint's martyrdom symbolically. Literary critic Shari Horner has also discussed the use of humour in Old English female martyr saints' lives, stating that it encouraged a symbolic understand of the dialogue between saint and pagan.

Different cultures, different concepts?

There is of course the challenge of identifying and defining humour from past societies: would medieval societies have found the same things “funny” that we do today? To counter the difficulty of identifying the presence, form, and purpose of humour in medieval saints' lives, my work examines modern theories of humour such as incongruity, superiority, and cognitive theories, and uses these approaches to put together the essential features of humour, as well as its technical applications and effects. My work utilises texts which detail how humour was perceived and used in the Middle Ages by engaging with

arguments put forward by Bakhtin and later counter-arguments. Similarly, my research applies modern and medieval conceptions of both violence and gender to medieval saints' lives, again engaging with modern theories of pain and violence. My work also engages with modern theories of gender, primarily focusing, however, on medieval perceptions of gender in a religious context.

I further refine my analysis of the function of humour by focusing on contemporary medieval instructional works and commentaries, particularly on the rhetorical treatises known as the *artes praedicandi* and earlier texts such as Augustine's *De Doctrina Christiana*. These contemporary sources provide precedents for humour as a tool for edification. Examining both medieval and modern thoughts on humour and how it may have functioned ensures that a comprehensive understanding of humour is acquired.

Holy humour and horror

My work investigates how humour was utilised during episodes of torture within saints' lives, and their ultimate martyrdom, examining the reasons why humour was portrayed in disparate ways according to the gender of the saint. The depiction of violent martyrdoms became more verbally embellished towards the end of the 13th century, and the use of humour more prominent, particularly in female saints' lives. Like Horner's symbolic interpretation, my research shows that humour was used to guide interpretation of such violence, ensuring that listeners understood correctly the intended doctrinal message underlying violent martyrdoms i.e. that the audience understood the violence symbolically, as opposed to literally. I examine how humour was used to distract or focus audience attention upon the tortures inflicted upon the saints, considering whether particularly violent martyrdoms were more significant in female lives, and addressing the rationale for this directed interpretation of violent episodes.

To achieve this, and to trace the development of humour and violence in saints' lives, my work looks at a wide range of lives spanning approximately a three hundred year time period: Ælfric's saints' lives, written circa the late 900s — early 1000s; anonymous saints' lives contemporary to these; the *Ancrene Wisse*, an instructional text written for anchorites, along with its associated Katherine Group saints' lives, written during the early 1200s; and the *South English Legendary*, first copied towards the end of the 1200s.

The body in medieval religious texts was often utilised as a personification of religious doctrine itself, or else guided how doctrine was intended to be interpreted by the audience. My work considers the concepts of the medieval religious body, and how gender may have been utilised in distinct ways to express a particular doctrinal message. This requires close examination of perceptions of both male and female members of the laity and those in religious orders, and their textual representations. Due to the nature of my research, how these perceptions changed and developed will also be examined, along with events that may have caused this. This will inform my own investigation of how humour was utilised,

and whether it would have been viewed by a contemporary audience as complimentary to, or subversive of the religious message of saints' lives. My work shows how the use of humour should not be attributed solely to works produced post-conquest, and that there was a literary connection between texts produced pre-conquest. The function of humour, particularly within episodes of torture, appears to have remained constant — this is not denying the shift in emphasis in the character traits of the saints themselves. While the more accepted and obvious use of humour increased throughout the centuries, the utilisation of humour itself should not be mistaken as a new development.

Conclusion

In essence, my work explores how humour may have been used to direct the audience away from worldly interpretations of violence in order to better instruct them in Christian doctrine, and how the use of such humour changed and developed from pre- to post-Conquest England. It considers possible models of audience response to such use of humour (for example edification, entertainment, laughter), and whether they may have existed simultaneously. My research also addresses whether the gendering of violence in relation to the use of humour was a preaching tradition continued from Old to Middle English lives. This first full-length study of the topic of gendered humour in this popular genre of medieval text differs from current research in that it covers a much more extended time frame, spanning both pre- and post-conquest England, thus allowing for an examination of the developing use of humour in religious contexts. A better understanding of how medieval authors intended violent episodes within hagiographic texts to be interpreted can be achieved by identifying and exploring how they deployed humour during these scenes. This expands current knowledge of medieval preaching practices, where these practices originated, and how they developed. In turn this provides a greater understanding of not just the purpose of saints' lives, but also of the societies and mind-sets that created, circulated, and listened to them, altering and refining our understanding of medieval uses and perception of humour.

With sincere gratitude to my supervisors, Dr. Thomas Birkett and Dr. Kenneth Rooney.

Can we ever have a 'right to die'? A reflective consideration of assisted suicide in Ireland

James Keogh

Department of Sociology & Philosophy, UCC

So the choice I have made
May seem strange to you
But, who asked you anyway?
It's my life to wreck,
My own way.
- Morrissey *'Alma Matters'*

Introduction

There is perhaps no greater moral or ethical quandary than reasoning to prematurely end a life; assisted suicide certainly resides within that contested bracket. Helping another to die is probably the most intensely personal test of individual conscience known to mankind. Most of us are shocked and revolted by murder, suicide and genocide, but when someone we know and love cries out, with justification, for help to die, how are we to respond? If we help to accelerate death in these circumstances, are we being ruthless or humane? There appears to be more questions than definitive answers surrounding one's 'right-to-die' emphasising the complexity of the issue at hand.

Numerous social and political commentators stress a need for 'serious debate' on this topic. But what level of discussion and interaction constitutes serious debate and where in the public arena is this to take place? To date, formal discussion on this issue has been severely limited. The topic of assisted suicide has however exploded to the forefront of Irish society in recent times. The occurrence of two high-profile legal cases in the past three years has sparked increased interest in this issue. Although these cases are tragic in nature because of their implicit relationship to circumstances pertaining to death, they have effectually forced society to give this subject the long overdue attention it deserves. In doing so, these cases have provided a voice for some of the most vulnerable in society — those who are suffering at the end of their days.

Legal contestations

In 2013 Marie Fleming, who suffered from Multiple Sclerosis (MS), took her case for the right-to-die through the judicial process. Her attempt in seeking that right failed in the High Court and that decision was subsequently upheld in the Supreme Court. Upon delivering his verdict, High Court President Mr Justice Nicholas Kearns described Ms Fleming as a 'humbling and inspiring' person and one of the most remarkable witnesses to come before the courts, while describing her experience as 'harrowing'. Although there were heartfelt and emphatic signs of sympathy shown towards Ms Fleming, the court fell short of granting her request to die at a time of her choosing. It had been hoped that Ms Fleming would secure an order requiring the Director of Public Prosecutions (DPP) to clarify its policy on the factors which would be considered when exercising its discretion to prosecute for the crime of assisted suicide. This approach would see assisted suicide remain a criminal offence, but members of the public would have a better understanding of the level of risk they would be exposed to should they assist another to commit suicide. The court refused to release a publication on such guidance.

In April of this year, the harsh reality of those 'levels of risk' became all too real when Gail O'Rorke was the first person in the State to be prosecuted under Section 2 of the Criminal Law Act, 1993. She was charged with aiding, abetting, counselling or procuring the suicide of Bernadette Forde in 2011 which carries a sentence of up to fourteen years in jail. O'Rorke denied that she attempted to aid and abet the suicide of Ms Forde by means of arranging travel to Zurich, Switzerland for such purpose. Furthermore, O'Rorke refuted that she procured the suicide of Ms Forde by means of making funeral arrangements for Ms Forde in advance of her death. Authorities were alerted after a travel agent became aware both parties were travelling to Zurich to visit Dignitas (euthanasia clinic). Any assistance, including travel aid of any description, under Irish law, is considered assisting a suicide. Having becoming concerned about implicating her friend in aiding her death, Ms Forde sourced barbiturates online from Mexico and administered a lethal dose at home alone. Gail O'Rorke was acquitted on all charges after evidence was heard via a Dictaphone recording from Forde herself exonerating the accused.

There are some poignant lessons to be gained from these trials which society must acknowledge. Their impassioned content profoundly exposes the plight of those who are forced to suffer against their wishes; the brevity of time between the two cases highlights the rapid growing demand for legislative change on this issue. Those in power cannot afford to sit on their hands and continue to ignore this topic. Interestingly, a recent Irish Times Ipsos/MRBI poll found fifty-four per cent agree there are circumstances where they would be willing to help a family member die. Dissecting those findings, over half of those surveyed would take the law into their own hands and risk fourteen years imprisonment to assuage the suffering of a loved one. What does all of the above suggest? What appears to be occurring is a reflective recalibration of public attitudes around assisted suicide in

Ireland. Evidently existing legislation no longer reflects public opinion on this matter. Therefore, is this democratically acceptable? The foremost aim of my research is to investigate the changing circumstances surrounding the fight for a right to choose to die and ultimately consider "can we ever have a 'right to die'" in Ireland?

Research aims and methodology

The right-to-die debate comprises of an amalgamation of competing claims. Its considerations include philosophical, ethical, moral, theological, and perceived 'rights' based contestations in the fight for recognition. The various elements of its rights' entitlement narrative reflect the input provided by legal, political, and social arenas, including the media. In particular this input pertains to the question of the individual's right to recognition (e.g., of autonomy, experiences of suffering, loss of dignity), equal opportunity, political representation and a voice before the law. Polemic interpretations of (in)justice highlight some fundamental issues at the core of this debate. An aim of my research is to analyse how political and legal actors both inside and outside of the dominant circuit of institutional power challenge traditional interpretations of justice on this issue. These actors not only call for a reform of the law in relation to the right-to-die, they also disclose new dimensions of justice that frequently transgress the established grammar of 'normal justice' (established legal-political and social interpretations of justice) exploring new conceptions of rights' entitlements in relation to this issue.

To gather these conflicting interpretations, I will employ a qualitative interviewing method. This will entail carrying out semi-structured interviews with those at the heart of this debate, consisting of influential legal and political actors as well as individuals directly seeking the right to die or those acting on their behalf. These interviews have yet to be carried out. I am currently at the stage of strategically identifying potential participants who will best reflect the associated contestations of the subject matter as ascertained from a preliminary review of germane literature. The advantage of a qualitative interview approach for my study lies in its facilitation of in-depth analysis of participant's subjective experiences, much of which will undoubtedly be highly emotive, sensitive, and outside the realm of rigid definable variables. This research method enables the cultivation and maintenance of sensitivity to the social, cultural, and the historical caveats of this debate, impossible to consider with quantitative methods.

Using this data, my analysis will follow the theoretical recommendations of Axel Honneth, who calls for a negative reconstruction of society. This stipulation permits the definition of justice to be 'provided by the criteria of the experiences of injustice rather than by a reconstruction of our intuitions of justice'.

Once my empirical data is assembled, I will juxtapose those interviewees' viewpoints to definitively identify the fundamental contestations within this debate. Each participant's justificatory reasoning will reveal both the 'for' and 'against' rationalisations ascribed to

the right-to-die argument. The legitimacy of each competing claim for rights entitlement will be philosophically mediated to test whether it matches contemporary society's expectations and the will of the majority of its people. Honneth's supposition of reconstructing a fairer society can only be met once injustice claims are brought together in a coherent framework for deliberation. A framing technique thus enables the researcher to assign 'value' to each competing claim. From here, a hierarchal ordering of these opposing assertions, in accordance to their resonance with society, will conclusively establish whether or not a call to alter existing legislation on the right-to-die is justified. To draw this conclusion I will reflect my qualitative findings against the principles of the most prolific social theorists and philosophers concerned with justice, human rights, theological and political philosophy. By interweaving participant's accounts of experienced (in)justice, political (mis)representation, media attention (or lack thereof), with the work of John Rawls, Amartya Sen, Axel Honneth, Rainer Forst and Nancy Fraser, will ensure the production of a comprehensive study producing the most fruitful empirical research of the right-to-die on these shores. That is the crux of my research.

Potential impact of this study

While researching for my Master's thesis in 2013, I discovered how underdeveloped this topic is in terms of sociological input. The vast majority of existing material relating to this subject in Ireland emanates purely from a legal viewpoint. A major drawback associated with this finding, which elevates the need for my research, is that legal studies themselves do not explore nor present the ever-changing expectations of society, which is a significant catalyst for policy reform. With the debate on the right-to-die still in its infancy here in Ireland, research investigating communication between and across distinct value perspectives as well as life experiences of the different actors involved in the Irish context is virtually non-existent. My study will acknowledge these considerations, therefore, making a new contribution to knowledge in this field. A sociological and philosophical perspective is needed to account for the numerous crucial dimensions of this debate including: how ideas of social justice come to be articulated by different actors in society, how moral-ethical learning is understood, how communication across differing value positions is facilitated by the media, how different actors interpret the importance of adapting to a changing Irish society, and whether or not the existing political model, seen throughout much of the democratic world actually facilitates or indeed hinders the resolution of moral-ethical dilemmas in society.

Rawls argues: 'Justice is the first virtue of social institutions... laws and institutions no matter how efficient and well-arranged must be reformed or abolished if they are unjust'. Potentially my study will advance greater public discussion on this topic in a formal capacity. For example, the then Tánaiste Eamon Gilmore, during Dáil proceedings, highlighted the need for a specialist report to be conducted by an 'expert group' to engage with the

right-to-die topic, submitting that 'members of the House should deal with the issue as legislators'. It is my plan to eventually make a considerable contribution to these proposed national policy decisions and offer my work either wholly or as a template for this possible engagement of reformation. My goal is to synthesise Irish research on this topic with our European counterparts and become the pioneer of sociological and philosophical research on competing justice frames on the right-to-die in Ireland. Being a leading researcher within this field promotes the importance of this study and its impact.

Conclusion

It is only through the disentangling and clearer reconstruction of the considerations contained within this subject that a more transparent framework for resolution can be found. Much evidence suggests more in-depth research is drastically required to classify this highly divisive topic as it has moved through various degrees of public debate recently — from the public arena, the media, and the Dáil to the High Court and the Supreme Court. My research will offer clarity to this often cluttered debate. Moreover, this cutting-edge study not only breaks new ground in a sociological and philosophical research sense, it will also provide a richly deserved platform of understanding towards those affected by this issue, whom are typically marginalised in society, to occur. Although Marie Fleming's method of dying was against her wishes after she was denied that 'right' having opted to enter formal judicial proceedings, she passed away surrounded by her family and partner Tom Curran. Bernadette Forde took the law into her own hands to relieve herself of her suffering. Feeling 'angry and frustrated' she died alone. Not because she did not have loving compassionate family and carers in her life. She was alone because the law required that she be alone. There is something fundamentally wrong in society when people are forced to such extreme measures. Because none of us know the circumstances or nature of our impending deaths, this issue has the potential to affect each and every one of us in the future. This study hopes to facilitate a more harmonious and ethically compassionate approach to this dilemma.

James Keogh is a PhD candidate from the Department of Sociology and Philosophy working under the supervision of Dr Tracey Skillington and Dr Cara Nine. The author would like to express his sincere thanks to those who have aided his research thus far, especially his parents. Also, a special thanks to Alison for her constant love, support, and understanding.

The Grendel-kin: From *Beowulf* to the 21st century

Alison Elizabeth Killilea

School of English, UCC

Introduction

Since the 19th century, the Anglo-Saxon poem *Beowulf* has received sustained critical attention; first transcribed and translated in the early 1800's, *Beowulf* was at a focus point in scholarly study, albeit not on the merit of its literary or poetic achievement. The text was valued more as an interesting linguistic document until what has been described as one of the most important turning points in criticism of the poem, J.R.R Tolkien's study *Beowulf: The Monsters and the Critics*, delivered in 1936. In this essay, Tolkien argued for the integrity of the poem in and of itself and for the central place of what are now often seen as the defining aspects of the poem: the monsters, who Tolkien argued held symbolic significance in the poem, and elevated it to more than just an exciting epic concerning the feats of the hero Beowulf against Grendel, Grendel's mother, and the dragon. Since Tolkien's essay, many more translations of *Beowulf* have appeared, joined in the 1950's by the first of many narrative adaptations, W.H. Canaway's *The Ring-Givers* (1958). Since then, numerous narrative retellings have appeared, most notably John Gardner's *Grendel*, along with comic adaptations, and — since the 1990's — numerous animated and live-action film adaptations, most famously Robert Zemeckis's 2007 *Beowulf*, memorable through the image of a naked Angelina Jolie as Grendel's mother!

My thesis aims to document *Beowulf*'s reception history, from the beginnings of its translation in the 1800's to its most recent adaptations of the last decade, exploring how these works have engaged not only with the poem itself, but also with scholarship surrounding the poem. Such a study will allow us to better understand these works' engagement with the poem in relation to contemporary social and philosophical contexts, and how the poem is used as a means to express modern issues and anxieties. Furthermore, a study of these works can also open opportunities for new readings of the poem and the characters within it, offering alternative viewpoints which may have previously been overlooked.

Of all the characters in the Anglo-Saxon poem, I would argue that the monstrous figures are the most appealing, and the ones who inspire the most creativity in adaptations; it is also through these figures that contemporary fears and anxieties are most clearly expressed in retellings of the poem. Despite Beowulf's role as the heroic protagonist, it is rather Grendel and Grendel's mother (and, to an extent, the dragon) who have captured

the imagination of modern day audiences, as can be seen in one of the more notable adaptations, Gardner's *Grendel*. Gardner's 1972 novel chooses to concentrate on the monster through a twentieth century perspective, one which is perhaps more likely to see the humanity in monsters. This twentieth (and twenty-first) century inclination to see humanity in, and sympathise with, monstrous figures, along with the morbid fascination with antagonistic characters, has led to many more interesting takes on these figures. Such examples can be seen in the sympathetic view of Grendel as a misunderstood outcast in Sturla Gunnarsson's *Beowulf and Grendel* (2005), and a rather surprising appearance of the poem in *Xena: Warrior Princess*, which chooses to focus on Grendel's mother, casting Beowulf as a rather unimportant and superfluous figure.

The translation of *Beowulf* in context

In order to understand how adaptations and translations engage with the original poem, one must go back to the original Old English in which it is written. Only then, for instance, can one begin to develop an understanding of the first translators' reception of the poem in the 19th century, and in the height of the Victorian era. Written sometime between the eighth and eleventh centuries in the West Saxon dialect of Old English, the poem is accessible to the majority of readers only through translation, meaning that the representations of characters are dependent on popular translations. As argued by many, from the Roman philosopher Cicero in the first century BCE, to the linguists Eugene Nida and Roman Jakobson in the twentieth century, the act of translation can never have absolute correspondence — i.e. there is never exact equivalence between two languages— and therefore, no exact translation can exist. This is especially true of a language like Old English, which hails from both a different time and culture. This lack of absolute correspondence allows for more subjectivity and freedom in translations, and much of this subjectivity, which is often shaped by cultural and societal norms, can be seen in the translations of Grendel's and Grendel's mother's characters.

Much of this subjectivity becomes evident in a reassessment of the Old English terms used to describe these two characters, where some meanings appear to be at odds with many translators' definitions. Through a study of these terms' etymologies and cognates, as well as their appearances in other works from the Old English corpus, a more objective sense of their meanings can be attained. Examples include the Old English *hilderinc*, meaning "warrior", literally "battle-man", which has been translated along the lines of "monster" by numerous translators, and *rinc*, simply "man", which has been translated as "creature", both of which are used in describing Grendel. *Hilderinc* and *rinc*, however, are used also throughout *Beowulf* in descriptions of non-monstrous characters, including Beowulf himself, and also appear throughout the wider Old English corpus in describing other admirable figures, such as Abraham and Enoch in the Old English *Genesis*.

This subjectivity is especially evident in translations of terms relating to Grendel's mother —

wif unhyre, literally “terrible-” or “fierce woman”, has received quite inventive translations, with translators, from Tolkien to Heaney, using extremely monstrous and bestial terms in translating this term. *Wif*, however, is used throughout the Old English corpus to mean simply “woman” or “wife”, while *unhyre* is used in texts such as the Old English *Genesis*, *An Old English Martyrology* and in *The Metres of Boethius*, with the meaning of “rough”, “grim” or “fierce”. This, along with the possibility of *unhyre*’s relationship to Old Icelandic *u-hýrr* (“unfriendly looking” or “unkind”) casts doubt on translations which demonise her character.

Such demonising terms are not too surprising, being influenced no doubt, from the very first translations which appeared in the early- to mid-1800’s. One feature of the Victorian era, was the re-popularisation of the pseudo-science physiognomy, which involved the assessment of an individual’s character based on their outward appearance, a — now wholly-discredited — “science” which we still see the effects of in many forms of media today, especially in children’s literature and film. The antagonists of such films as *The Lion King* and the *Harry Potter* series, for instance, namely Scar and Voldemort, may be described as somewhat less aesthetically pleasing than the heroic figures of the stories! The influence of physiognomy can be seen throughout Victorian art and literature, and is notable in works by Charlotte Brontë, Charles Dickens, and Oscar Wilde. Morally corrupt figures were often ascribed physically repellent features, an aspect which has arguably been carried over into the translations of *Beowulf*. Grendel and his mother, both of whom were seen as morally inferior characters, were given exaggeratedly repulsive features as a means of expressing their morally repulsive dispositions.

The Victorian translations were also most likely influenced by the prevailing view of women at the time — the Victorian period is notorious for its strict policing of women’s femininity and sexuality; those who swayed from the ideal functions of marriage and procreation were often deemed abnormal, and those who took on active roles were often ascribed unattractive features, as exemplified in caricatures of suffragettes from the late Victorian era. Descriptions of Grendel’s mother are not so far removed from the descriptions of Becky Sharp in William Thackeray’s *Vanity Fair*, an autonomous figure who is described in physically monstrous terms, and is the binary opposite of Thackeray’s heroine, the passive and compliant Amelia Sedley. As is the case for Becky Sharp, Grendel’s mother also appears to have a binary opposite, seen in the virtuous figure of Queen Wealhtheow, a character frequently compared to the Virgin Mary in Christian readings of the poem. The polaric view of women used in both Victorian texts and in translations of *Beowulf* appears to be influenced by the more Medieval Madonna-Whore (or Madonna-Eve) dichotomy, manifesting into an Angel-Demon dichotomy for the more secular Protestant England of the 1800’s. Although these societal views have changed, the Victorian translations still appear to have considerable influence on modern translations, the monstrous view of Grendel’s mother still remaining intact, despite the very real possibility that she was constructed as a human figure in the Old English text.

Back to the future

The visions of Grendel and his mother have remained relatively unchanged from the Victorian period within translations, the only real deviations appearing within adaptations of the poem. Despite the temptation to write off many of these adaptations as uninformed pieces of popular culture when comparing them to the original poem, they often show critical engagement not only with the text itself, but also with scholarly trends and academic debate. Even the most unlikely adaptations, such as Robert Zemeckis's 2007 *Beowulf*, appear to be rather well informed about the poem, seemingly influenced by a number of different scholarly debates on both the poem and other Anglo-Saxon and Norse texts. Perhaps the most unorthodox imagery in Zemeckis's offering is the image of Grendel's mother, a curvaceous, naked and golden figure who seduces Beowulf. Such an image (which for many readers of *Beowulf* was no doubt close to being blasphemous) appears to have its roots in scholarship, in particular the work of Frank Battaglia, and is a probable reference to an ancient Germanic fertility goddess, Gefion, albeit a somewhat more sexualised representation of her!

The sexualisation of Grendel's mother's character in Zemeckis's adaptation, along with Graham Baker's techno and back-flip filled 1999 adaptation featuring Christopher Lambert of the *Highlander* series, is itself also arguably influenced by *Beowulf* scholarship and Jane Chance's claim that the battle-scene between Beowulf and Grendel's mother in the poem contains sexual undertones as the two characters struggle for a dominant position astride the other. The fight comes to an end when Beowulf spots a sword of gigantic proportions, which it is said only he could wield in battle, a line reminiscent of *Riddle Twenty*, "The Sword", in the Anglo-Saxon Exeter Book, a double entendre which uses phallic imagery. With these scholarly debates in mind, the sexualisation of Grendel's mother, although taken to extremes in the film, is not as far-fetched as it first appears.

As well as this, the depictions of these two characters can often be seen to be changing in response to their own social and historical backgrounds; Gardner's *Grendel* can be seen as a manifestation of the increasing anxieties about conflict and 'The Establishment' in the latter years of the Vietnam War, and consequently the increasing suspicion of the 'hero'. Instead, the post-war era gave rise to the anti-hero, prevalent in many American novels of the sixties and seventies, such as Billy Pilgrim in Kurt Vonnegut's *Slaughterhouse 5* (1969) and Randle McMurphy in Ken Kesey's *One Flew Over the Cuckoo's Nest* (1961), and, in a British context, Alex DeLarge in Anthony Burgess's *A Clockwork Orange* (1962). As with all these characters, Grendel may be described as being opposed to the ideological values of 'the System', albeit in this case, the Anglo-Saxon system of norms.

On the other hand, *Xena: Warrior Princess* may be described as an extension of the 1990's and 2000's cultural phenomenon of "Girl Power", originally associated with Riot Grrrl punk bands like Bikini Kill and Bratmobile, and ultimately epitomised in the Spice Girls. This pop culture aspect of third-wave feminism can also be seen in numerous television

shows of the period, such as *Buffy the Vampire Slayer*, and in films such as the 2000 reboot of *Charlie's Angels* and the game-to-screen adaptation of *Lara Croft: Tomb Raider* (2001). Like Xena, Grendel's mother (here called Grinhilda), aims to show that girls don't have to give up beauty, skirts, and boys (or girls) to be a warrior.

Zemeckis's *Beowulf* then, one of the most recent adaptations, can be seen to represent the culmination of twenty-first century trends, especially those of the action and fantasy genres. It appears to follow the more recent trend of sexualising female monster (or often alien or robot) figures, a feature seen also in Letterier's remake of *Clash of the Titans* (2010), in Kusama's *Jennifer's Body* (2009) and more recently, although to a different effect, in Glazer's *Under the Skin* (2013) featuring Scarlet Johansson, a trend which is now starting to see a backlash, evident in films like Alex Garland's *Ex Machina* (2015). Anxieties expressed in this adaptation appear to revolve more around fears of sexuality and masculinity, as opposed to the war-related concerns of Gardner's *Grendel*, anxieties which are surprisingly not far off those of the Victorian era, where sexually powerful women are demonised or made unnatural.

Conclusion

These examples serve to demonstrate just a small number of the ways in which adaptations and translations react and engage with the original Anglo-Saxon poem and with their own social context. The almost constant stream of translations and adaptations show that there is something in *Beowulf* which society relates to, and, especially through the characters of Grendel and Grendel's mother, these things become evident, whether it be the anxiety of war as told through the figure of Grendel in John Gardner's novel or the anxieties of twenty-first century sexualities in Zemeckis's 2007 film adaptation. Through this study of *Beowulf's* reception history, my research will document how translations and adaptations have engaged with the poem, and have used it as a blueprint on which to lay out contemporary concerns, and in doing so, will also aim to give often dismissed adaptations the scholarly interest they so far lack.

“I am going abroad to study English”: language learning beyond words and grammar

Annarita Magliacane

Department of French, UCC

Learning another language is not only learning different words for the same thing, but learning another way to think about things (Flora Lewis, Dialogue among Civilizations, United Nations, New York, 5 September 2000)

Introduction

Studying abroad, and particularly in an English-speaking environment, has become very popular among English learners in the last few decades. Every year, thousands of students leave their own countries to start or to continue their university studies in an English-speaking context. One of the reasons behind this trend is that living in the target language community, i.e. the country where the language learnt at school is officially spoken, provides them with more opportunities to learn a language than in their homeland. In fact, there seems to be a general consensus among teachers, students and parents that a period of time spent in the target language community by the ‘instructed learner’, i.e. the student who has mainly studied the language in a classroom setting outside the target language community, is beneficial to the acquisition of a foreign language.

Seeing the “new” world through the eyes of a child

Students, upon their arrival in the target language community, often mention that in a study abroad context they can learn English faster and better than they can do in their home countries. They often report having more opportunities to practise the language, to speak English in and outside the classroom with their friends, instructors, housemates, local people that they meet, for instance, while waiting for the bus or queuing at the supermarket. In the first few weeks they have the impression of learning a lot, especially in terms of lexicon in relation to their daily life. For example, they start learning to name the kitchenware or the different ways of referring to cleaning products, which are not simply ‘the soap for’, as they might say when trying to recall the most appropriate word or try to explain what they are referring to.

This gives them a sense of excitement as they expand their vocabulary very quickly and this way of learning seems very different from the teaching style in their home countries

where all these words are generally not taught. The speaking practice is often limited to a few ‘discuss with your partner’ oral exercises where students are supposed to orally reproduce with a classmate what is written in a dialogue, using more or less the same linguistic structures, i.e. the manner in which words, grammar, syntax, and the meaning of words are organised and used. They also often complain that in their home countries they learn to speak about very serious issues, such as pollution or globalisation, but they often do not know the names of ‘that thing for a headache’ or ‘that thing to use when the battery of your phone is dying’, which are useful things in their everyday lives.

Thus, because of this sense of general improvement in the foreign language, study abroad is so common, popular, and for some students, even trendy. In fact, today the so-called ‘experience abroad’ is no longer exceptional but is often part of a university path and is considered by many to have a fundamental role in the lives of young people. Therefore, most students, especially at third level, spend part of their studies in another country for a short while, commonly availing of grants or little subsistence, provided by the European Union or similar organisations. These funds, together with the current European policies, seem to favour students’ international mobility and enhance the idea of the desirability of the experience abroad as they contribute to foster the popular belief, giving it even a sort of scientific aura.

The grass is not always greener on the other side

However, this honeymoon phase of living abroad is not supposed to last until the end of the experience. Little by little, the students realise that they had more expectations about their language learning abroad in particular with regard to their relationships with the local people. Despite the fact that they might practise the language more frequently in comparison to their home countries, where the chances of using the language might be limited to the classroom setting, their expectations regarding their social participation in the target language community and, in particular, their interaction with the local people, might not be totally fulfilled. In fact, it seems that they expected to have more Irish friends and further chances of practising the language with native speakers. After a few weeks they realise that it is easier to “hang out” with other international students. They share the same experience, they go to the same events which become a sort of “chain reaction” with regard to students’ social networks. For example, one of the students who took part in the project said

“Your French friend will introduce you to more French people, who will introduce you to other students, who are often French or international students”.

Interaction with native speakers is often limited to superficial conversations, such as housekeeping or asking university staff, other students or local people for general information. In these conversations with native speakers, the students feel that the language

is still a problem, sometimes even a barrier, for them. The accent is very hard and sometimes they do not manage to understand even words or structures that they know or they should know. One of the students interviewed, for instance, mentioned, during one of the meetings, how she found out that some sounds in Irish English are pronounced slightly different from the so-called standard pronunciation that she was taught in the classroom. At the very beginning of her experience, even a simple question ‘Are you going to take the bus?’ was the cause of a puzzled expression on her face. She understood most of the words; she recognised the grammatical structure (her teacher in Italy called it ‘intentional future’), but she could not figure out what her interlocutor meant with the last word which sounded to her ears something like ‘boss’.

However, while one may think that the accent is one of the main issues that might cause misunderstandings, there is much more beneath the surface. Although all of the students interviewed mentioned that the accent in Cork is quite difficult for them, when asked what the oddest thing was to them about Irish people, only a very small percentage mentioned the accent or their way of pronouncing some particular words, like ‘bus’, ‘pub’ or ‘Dublin’. The majority of the students interviewed found it very awkward that such a welcoming and nice community

“if they see you in the street with a map, they will ask you if you need help” (said one of the interviewees)

have the strange habit of asking about the general health of their interlocutor (“Hi, how are ya?”), but they do not seem very concerned about their response. Actually, before the students could even utter a sound, Irish people are miles away, no matter what the response is.

Beyond linguistic competence

Why does this happen? What is the cause of this break in communication? When non-native speakers of English start learning the language they probably came across dialogues like the one below:

Margaret: Hi Ann. How are you?

Ann: I am fine, thanks. And you?

Margaret: I feel bad. I think I am sick.

Ann: I hope you feel better soon

Therefore, when they meet a person or they are asked ‘How are ya?’, they would like to reproduce the same type of conversation or, at least, this is what they expect to happen, but, strangely, the interlocutor does not wait for their response.

Whereas for Irish people ‘Hi, how are ya?’ is simply a way of saying ‘hello’, students probably find it awkward as they do not understand exactly the pragmatic intention of the utterance, as linguists would say. What do linguists mean by ‘pragmatic intention’?

Pragmatics is a branch of linguistics which studies how the language is actually used rather than how it should be used. The word ‘pragmatic’ is also used in everyday language to describe a person who likes to solve problems in a practical and sensible way, rather than relying on fixed rules or dogmas, and that is basically what this branch of linguistics does. Instead of relying on the knowledge “by the book”, pragmatics tries to find out the deeper meaning, considering other factors, like context, background knowledge of the speaker and the listener, and also the place where the language is spoken.

English, in fact, is not always the same everywhere and rather than speaking of English, we should speak of Englishes. Students in their classroom are probably exposed to one of the most important varieties of English, the so-called Standard English, which is the most prestigious one but, at the same time, the least frequently spoken. Thus, the fact that the students might find it strange that Irish people do not respond to ‘how are you?’ might be related to other factors, which are beyond the morphological level, i.e. the words that are actually written or pronounced. Moreover, when Irish people do respond to ‘How are you?’, they rarely use ‘Fine, thanks’ but they might use other equivalent expressions, which might sound a bit weird to a non-native English speaker’s ears. For instance, they might say ‘Not too bad!’, even though there is nothing wrong with them, or ‘I’m grand!’, which might sound as if they had won the lottery or they are overexcited.

Thus, language varies, from country to country, where it is officially spoken, from region to region and, even within the same community. This is an important factor to consider while analysing the language development of students who live in the target language community and will be exposed to that language, or, as some linguists would name it, variety. This language input may have some effects on their language development; they may pick up some of the features of the variety consciously, for a sense of group inclusion or simply imitation, or unconsciously, i.e. they only reproduce what they hear. Otherwise, they might simply become well aware of the fact that English varies and it is not just what is in the book.

The aim of my research

By focusing on the fascinating field of pragmatics and language variation, the aim of my research project is to analyse how students’ language skills develop over a period of time spent abroad. In particular, I will focus on how they connect and organise what they say. In fact, the language of second language (L2) users, especially of learners who have mainly studied the language in a classroom setting, seems to be quite static, a series of ‘frozen chunks’. This might be a consequence of the input they received in the classroom environment, where they were taught ‘functions’, the language that they can use to perform particular actions, always applicable to any situation and context, like a maths equation, where $1 + 1$ is always 2.

Because of the input they receive from the world outside them, they might tend to structure their speech in a different way and use words, particles or connectors that they did not use before. These markers, often referred to as ‘discourse markers’ in linguistics, are so frequent in our first language that we cannot even utter a sentence, without saying ‘you know’, ‘I mean’ or ‘well’. However, they are not that frequent in the speech of L2 users, as they have probably never been taught how to self-correct their thoughts, or how to convey a particular feeling while speaking. These words do not add a particular meaning to what is said (‘John won the lottery’ = ‘John won the lottery, would you believe it!’) but, at the same time, they are not simply added to it. They make the conversation sound more real, more native-like; in other words they have an important pragmatic function.

Therefore, my research is investigating whether students start using discourse markers differently in their speech after living abroad for a while. The research is mainly interview based and includes two interviews, one upon arrival in Ireland and the second one a few days before students’ departure. This longitudinal approach will help to assess whether there is a change in the way students tend to organise their speech after the experience abroad by comparing the results of the two interviews. In order to favour the production of natural and spontaneous conversation, a friendly setting has been reproduced and interviews have been conducted while having a coffee with the participants. Topics of the interviews ranged from daily routine, university studies, future plans and differences between Ireland and their home countries. The transcription of the interviews has allowed to analyse the most frequent markers used by each speaker and to compare the results with those of the other participants, in order to assess trends, similarities and differences.

In addition to the participation in the interview, participants have been also asked to complete two questionnaires, one upon arrival and the other one before their departure. These questionnaires have been devised to provide information about the informants’ learning expectations, their degree of interaction with the local community and to corroborate information given during the oral interviews. Preliminary findings suggest that the experience abroad seems to favour the use of more markers in learners’ speech. Some learners also started using some discourse markers typical of Irish English, such as the use of ‘like’. It is hoped that further research and the collection and analysis of more data will corroborate those preliminary findings and will help to assess whether a link exists between a study abroad experience and the development of some native-like features in speech.

Towards a new concept of proficiency

What is ‘native-like’ then? A lot of people think that ‘native-like’ might be connected to an extensive knowledge of lexicon or grammatical accuracy. That is true, but it is not limited to that! Knowledge of variation is also a fundamental part of speakers’ abilities, and to become proficient in a foreign language, learners might need to acquire some native speakers’ patterns of variation. This might lead to rethink the concept of proficiency

according to new socio-pragmatic terms, where the prefix ‘socio’, added to the word ‘pragmatic’, stresses the importance of the social dimension of the language. In a study abroad context learners may improve their lexicon, fluency, grammatical accuracy, but there is more beyond words and grammatical rules that they can learn and this has to be considered when assessing the language development of students in a study abroad context.

I would like to thank my supervisors, Dr Martin Howard (University College Cork) and Dr Paolo Donadio (University of Naples Federico II), for their invaluable support, insight, and encouragement while conducting this research. I am also extremely grateful to the volunteers, who kindly agreed to take part in this project, and the UCC Strategic Research Fund for making this research possible. I also would like to express my gratitude to the Department of Humanities and the Department of Political Science of the University of Naples Federico II.

The censorship and suppression of Cork's nationalist and loyalist newspapers during the Irish Revolution, 1916-1923

Alan McCarthy

School of History, UCC

Introduction

The Irish Revolution was an epochal period that saw the Irish nationalist movement seek to obtain independence from the British Empire. It has received extensive scholarly attention, particularly the century-shaping 1916 Rising, the guerrilla war campaign that coloured the War of Independence 1919-1921, and an implosive Civil War between those for and against the Anglo-Irish Treaty, that raged between 1922-1923 and continues to shape present-day politics in Ireland. Key to understanding Cork, the epicentre of revolutionary activity post-1916, is an engagement with its widely-read newspapers of the time. During this period West Cork's Southern Star and Skibbereen Eagle, and Cork City institutions, the Cork Examiner and Cork Constitution, acted as central actors, in conjunction with their role as reporters, in the equally significant battle for hearts and minds. The consequence of the key propaganda role played by these papers would be intense censorship and suppression by both Crown Forces and the military wing of the Irish nationalist movement, the IRA. While this may seem insignificant to present-day readers, who have unfettered and constant access to news and information, the suppression experienced by these newspapers occurred at a time when newspapers were integral to the dissemination of ideas and opinions, owing to the absence of competition from the internet, radio or television. Moreover, the media dimension to the Irish Revolution has often been overlooked by academic historians, who tend to view these papers as historical sources as opposed to the historical forces that they were. Consequently, the aim of this research is to engage with the suppression of these papers, which represented a devastating curtailment of freedom of speech, as well as highlighting the influential role these papers played in moulding public opinion during this pivotal period in Irish history.

West Cork

The Skibbereen Eagle was the elder statesman of the West Cork papers. Originally a four-sheet paper containing mainly advertisements and snippets of local news, the Eagle has the distinction, rather ironically, of being the first publication to publish a poetic verse by famed Fenian Jeremiah O'Donovan Rossa. Following a brief period of championing

John Redmond's Irish Parliamentary Party, the savagely "anti-republican" Eagle would become radicalised during this period, becoming more outwardly loyalist in tonal quality. Such were the efforts of the Eagle that Managing Director Eddie Swanton would, in his compensation application to the Irish Grants Commission, claim that the newspaper

"in its own area did more for the support of the British Empire than any other newspaper in Ireland."

Intended to oppose the Eagle's advocacy of maintaining the Union between Britain and Ireland, the Southern Star was founded by John and Florence O'Sullivan in 1889. Such was the extent of the suppression experienced by the paper during this period that Liam O'Regan would write in the Southern Star's Centenary Supplement that

"The Southern Star can claim a special interest in press freedom because without contradiction, it can claim to be Ireland's most suppressed newspaper during the War of Independence."

The adoption of a determinedly more radical nationalist outlook in the aftermath of the 1916 Rising led to the Star's first experience of suppression under the orders of General Maxwell. Following its acquisition by Sinn Féin, the political party of the revolutionary movement, the Star became a veritable 'who's who' of Cork republicans, as influential figures, such as Michael Collins, became shareholders, along with the employment of other notable individuals like Gaelic League activist Peadar O'Hourihan, T.D. Sean Hayes, and labour leader Tadgh Barry, along with future Minister for Finance Ernest Blythe; Seamus O'Brien, who would go on to marry James Connolly's daughter Nora, served for a period as office manager.

Increased radicalisation resulted in increased suppression, which was often met by an air of inevitability. The Star was shut down on four more occasions by the British administration during this period, usually for breaching the Defence of the Realm Act (DORA), including lengthy closure during 1918, 1919 and 1920. Brought into being following the outbreak of World War I in August 1914, DORA afforded the British state a host of measures, formalised in an extensive set of Defence of the Realm Regulations (DRR) which, most importantly, permitted the seizure of printing presses and made sedition in print a court-martial-worthy offence, proving a massive hindrance to the republican press.

While DORA was relaxed in 1919, the dumping of machinery belonging to the Eagle into the River Ilen in 1920 by the IRA served to be another unwelcome reminder of the advent of censorship and suppression in Ireland. The impact of such actions is showcased by the revelatory comments of Eddie Swanton to the Irish Grants Commission, in which he claims that

"circulation was continued only with the greatest difficulty" as "attack after attack was made on the paper."

The Eagle's first taste of suppression arrived in 1917, with company secretary James O'Driscoll recalling that

“the Eagle office was raided by armed and disguised men, the machinery broken and considerable damage and confusion caused.”

The plant of the Eagle would be destroyed again in early 1918 in light of its continued “anti-National and pro-British” general policy, while P. Sheehy, the “brilliant poet editor of the Eagle”, suffered the indignity of being tarred and feathered. The paper also had a boycott imposed upon it during 1920, with copies of the weekly paper being stolen and burned publicly in some instances. The Eagle, however, was only compensated for the value of the copies burned during the boycott, thus ignoring the significant loss of income caused by the disruption to its circulation, as the paper's irregular appearance discouraged regular subscribers from buying it. As a result, this West Cork weekly found itself creeping towards insolvency. Continued suppression and agitation from the IRA would eventually force the closure of the Eagle offices in July 1922.

Cork City

The Eagle's political mirror in the City was the Cork Constitution. While R.B. McDowell noted that the Constitution

“forcefully advocated the unionist cause in the south,”

to present-day readers the name Cork Constitution is more readily associated with the rugby team of the same name. Founded in 1892, the rugby team was bank-rolled by Managing Director and Editor H.L. Tivy, who also served as the club's first president, while several players would enlist to fight for 'King and Country' in World War I. The Constitution's sparring partner for close to a century was the Cork Examiner. Within the offices of the Examiner there existed an opposition to militarism since the days of its founder, John Francis Maguire. Situated at No. 95 Patrick Street, Editor George Crosbie and his staff witnessed more violence than any other paper in Cork, a point overlooked by those who have attempted to explain the Examiner's pacifistic approach to the revolutionary period, with the paper condemning the violent activities of the IRA and forces of the Crown in equal measure. In December 1920 alone the staff witnessed Auxiliary police officers flogging people outside the Examiner office, while the city centre itself would be razed to rubble mere days later in the infamous 'Burning of Cork.'

The Examiner suffered under the Crown's censorship for the first time in September 1919 for advertising the Dáil Loan. This marked the beginning of a few intense years of agitation which would see the paper raided by the IRA and harassed by the Crown, while both republicans and the 'Anti-Sinn Fein Society', a loyalist group considered to be a front for unofficial reprisals by Crown Forces, forced the paper's staff to insert notices into the paper at gunpoint. In 1923, republicans burned Crosbie's home to the ground, while office

manager Denis McGrath was shot and seriously wounded. Of the papers concerned, the Constitution would be the only one to survive the War of Independence largely unscathed. Like the Eagle and the Examiner, the Constitution would have its presses wrecked by the IRA in early 1920, while Tivy was ordered to leave the country by militant republicans. Later in the year Tivy received a letter, informing him to prepare for execution. Undaunted, he maintained his role and continued to criticise the IRA. The anti-Treaty faction would, however, assume control of Cork during the Civil War, with republicans establishing a rigid censorship over both the Constitution and Examiner during the summer of 1922. Unwilling to submit to this censorship, Tivy shut down his paper indefinitely in July of that year, mirroring the decision of the Eagle, which had closed its doors a week earlier due to continued harassment. Weeks later the offices of both the Constitution and Examiner were destroyed by anti-Treatyites evacuating the city following the amphibious landing of Free State troops in Cork.

Conclusion

The closure of Cork's loyalist newspapers, brought about by the greater severity of IRA censorship as opposed to the British administration, highlighted the furious zeal with which censorship could be conducted in this country, and represented the loss of two journals of admirable journalistic merit. In the present 'Decade of Centenaries', this research will encourage closer engagement with the role of the media in the Irish Revolution and serve as a timely reminder, at a time when we take freedom of information and the freedom to access this information for granted, that editors, reporters and journalists alike suffered grievous harassment and suppression in order to circulate the news to their respective communities.

Alan McCarthy is a First-Year PhD student in the School of History, under the supervision of Dr Donal Ó Drisceoil. The author wishes to thank both Dr Ó Drisceoil and the College of Arts, Celtic Studies and Social Sciences, who have supported this research via a PhD (Excellence) Scholarship.

“What will happen when I can no longer cope?” Burden in caring for people with severe mental illness

Zamzaliza Abdul Mulud

School of Nursing and Midwifery, UCC

Mental illness is nothing to be ashamed of, but stigma and bias shame us all. (Bill Clinton)

The case study

Jane is a 55 year old woman, who cares for her son with schizophrenia. When Jane is asked about any difficulties in caring for her son, she becomes tearful as nobody has ever asked her about her feelings before. Jane believes that caring for her son is like carrying a heavy load because sometimes she cannot cope with the demands of caregiving and as a result she always feels overworked, stressed, angry, and dissatisfied. She also suffers a great deal of shame and embarrassment associated with her son’s behaviour problems. Jane shared her experience of her son’s behavioural problem :*“Yesterday, he took off his clothes in the shopping mall, where there were a lot of people. It was such an embarrassing situation. Furthermore, the people around there were telling others that I am his mother. I felt so embarrassed”*. This case study reflects the common scenario experienced by caregivers of people with severe mental illness on the daily basis.

Introduction

Mental health problems affect millions of people worldwide. It affects not only patients, but their family members and the community as well. The de-institutionalisation of patients with mental illness from hospitals to community care has resulted in greater involvement of informal caregivers in the patient’s management. Furthermore, due to the chronic characteristics of mental illnesses, patients often require long periods of care, thus caregivers are left with no choice other than adjusting their life to accommodate these changes. Some caregivers were able to adapt to the new role successfully, but others experienced a significant level of burden. As illustrated in the above case study, caring for individuals with mental illness proved to be more challenging than caring for individuals with other illness.

In the current health care system, informal caregivers of people with severe mental illness play a crucial role in influencing patients’ prognosis and reducing rates of hospital admission, relapse and episodes of self-harm. However, studies of caregivers have shown that

caring for individuals with severe mental illness often impacts all domains of caregivers' lives, including work, leisure, income, physical and emotional health and significant relationships with other people. Previous research findings have also shown that tiredness, sadness, constant stress, uncertainty and frustration were the common feelings of burden expressed by caregivers. In addition, unlike other chronic illnesses, the stigma often attached to mental illness (as illustrated in Figure 1) was a significant factor in greater caregiver burden and caused caring for people with mental illness to be a more stressful experience.

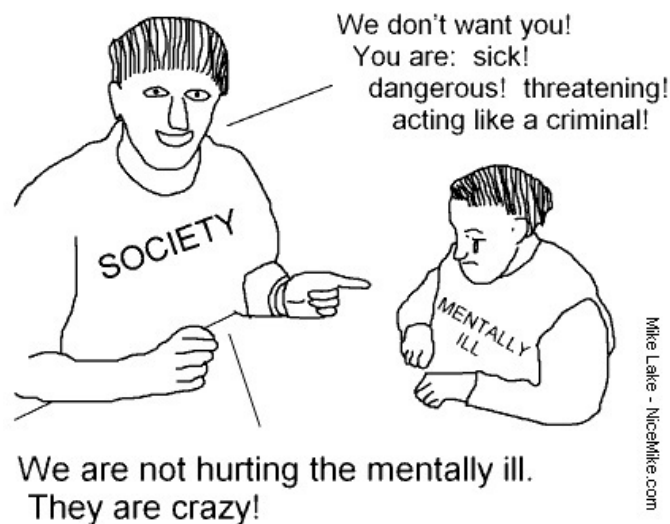

Figure 1: Stigma of mental illness — Source Mike Lake, www.nicemike.com

Factors influencing caregiver burden

It is widely accepted that the factors associated with caregiver burden are complex and multi-dimensional. Efforts are being made internationally to identify factors that contribute to caregiver burden so that the appropriate interventions, which are targeted towards these populations, can be identified. Caregiver burden has common causes (shown in Figure 2) and findings from previous studies suggested that caregivers who are older and female, those with depressive symptoms and with a higher self-perceived stigma were more likely to report a higher level of caregiver burden. Besides these, other factors that were found to be associated with caregiver burden include availability of social support. However, some of these factors are not conclusive in predicting caregiver burden. For example, a study in Malaysia among caregivers of patients with dementia found that low external support received by caregivers was associated with caregiver burden. Yet, contrary to the findings in the Malaysian study, a study done among Italian caregivers of patients with the same illness indicated that the lack of social support was seen as having not contributed to a burden. Thus, the cultural differences in caregiving and coping style may also reflect differences in the way caregiving affected caregivers from different ethnic groups and cultural backgrounds.

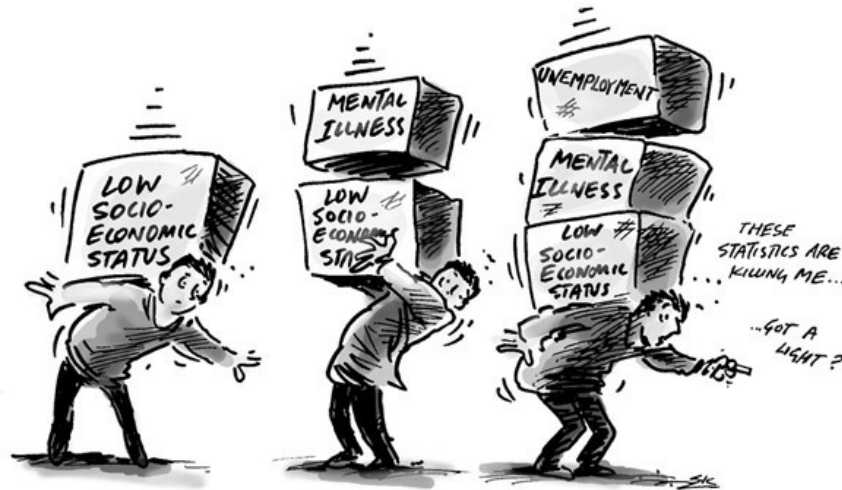

Figure 2: Multidimensional factors that contributed to burden in mental illness. Source: Simon Kneebone

Despite the inconsistencies in the literature about the factors that contributed to caregiver burden, resilience might be the key to explain how caregivers ‘bounce back’ and deal with challenges in caring for individuals with severe mental illness. Alongside caregiver burden, resilience is included in the present study in order to recognise the potential for personal growth associated with the caregiving role. This is another approach to understanding what caregivers experience in dealing with patients of mental illness, without denying the existence of burden and stress felt by caregivers. Previous studies among caregivers of elderly people with Alzheimer’s disease, female caregivers of individuals with serious mental illness and child caregivers found that those who were more resilient reported low levels of burden in caregiving.

Nevertheless, in the Malaysian context, little is known about the experience of caregivers in caring for individuals with severe mental illness. There are few studies done on caregiving that focus on caregiver burden among patients with dementia and Parkinson disease, except for one qualitative study which was focused on caregiver burden among caregivers of patients with mental illness. The factors associated with caregiver burden and resilience are well established in Western countries and in some Asian countries. In Malaysia however, since the studies are limited in this area, little is known about the magnitude of caregiver burden and the impact of resilience among caregivers caring for individuals with severe mental illness. The paucity of research on caregiver burden and its associated factors among Malaysian caregivers of individuals with mental illness suggests that research is needed to address this issue.

My research

Aims and design

The primary aim of this quantitative, correlational study design was to examine the association between caregiver burden and caregivers' demographic backgrounds, caregiving-related stressors and resilience among the population being studied. The development of a conceptual framework for this study has been guided by the Pearlin Stress Process Model, and the Model of Carer Stress and Burden, as well as findings from a comprehensive literature review. In this conceptual framework, there are three factors that contribute to the outcome of caregiver burden, namely the background and context of caregiving, primary stressors and resilience. The sampling frame of this study was composed of a list of caregivers of individuals with severe mental illness attending Psychiatric Outpatient Clinics in Malaysia. Two clinics were selected as they serve as reference centres for severe mental illness for cases around West Malaysia. Self-administered questionnaires were used to collect data and at the end of the data collection period, 201 caregivers participated. The ethical approval to conduct this research was granted by the Medical Research and Ethics Committee, Malaysia and the University College Cork Clinical Research Ethics Committee.

Findings

Findings from the present research contribute to the growing evidence of the role of caregivers' socio-demographic variables, caregiving-related stressors and resilience towards caregiver burden. The results of my study indicate that caregiver burden was greater for older and female caregivers, members of the Chinese ethnic group who were unemployed, divorced or widowed, those with a perceived moderate health status and having a medical problem. On the other hand, caregiving-related stressors that were significantly associated with caregiver burden included longer time spent on caregiving activities, insufficient emotional support and support with caregiving tasks and assistance as well as patient behavioural disturbances. Finally, the findings also supported the hypothesis of the study as there was a significant relationship between resilience and caregiver burden. A moderate negative correlation indicates that increases in resilience correlated with decreases in the level of caregiver burden.

One interesting finding of this research highlighted that women caring for individuals with severe mental illness (like Jane, in the case study) were at higher risk of burden compared with male caregivers and this finding was supported by results from previous studies. The Role Theory suggests that an individual's social behaviour largely depends on society's expectation of the role that the person is assuming. Therefore, women who have always been considered as the caretaker must take up the role as a caregiver, whether they are willing or prepared to do so or not. Besides, female caregivers were more often subjected to stigma, guilt, caregiver strain and client dependency than their male counterparts-

possibly explaining why female caregivers reported higher levels of burden.

Finally, it can be concluded that the caregiving burden is a common phenomenon that is shared by caregivers from various cultural backgrounds, although the contributing factors might differ from one population to another. The findings from this research also highlight the fact that mental illness affects not only patients but their family members as well. Thus, it is important to identify burden among caregivers caring for individuals with mental illness. Nurses or other health care providers need to be cognisant of caregivers' levels of burden and distress in caring for patients with severe mental illness. This evaluation should be done as part of an assessment, particularly when caregivers accompany patients for their follow up -or during the home visit. Furthermore, informal caregivers should be actively included in the patients' management and interventions so that the caregivers are able to recognise any changes in patient's behaviour and respond accordingly.

I would like to thank my supervisors Professor Geraldine McCarthy and Dr Mary Rose Day for their support and guidance. I wish to acknowledge the Ministry of Education, Malaysia and Universiti Teknologi MARA, Malaysia for the financial support of the study.

To bee, or not to bee? Honey bees, Boolean logic, bits and information

Fiona Edwards Murphy

Electrical and Electronic Engineering (EEE), School of Biological, Earth and Environmental Sciences (BEES), and Environmental Research Institute (ERI), UCC

Human beings have fabricated the illusion that in the 21st century they have the technological prowess to be independent of nature. Bees underline the reality that we are more, not less, dependent on nature's services in a world of close to 7 billion people. (Achim Steiner, Executive Director UN Environment Programme)

The importance of Honey Bees

What would happen if the honey bee disappeared from the face of the earth? Honey bees do not just produce the honey and wax we use every day; they serve the vitally important function of pollination, in which pollen is moved from one plant to another for fertilisation. 70 of the 100 crop species which provide 90% of food worldwide are pollinated by bees. The value of honey bee pollination to the global economy (€153 billion annually) now vastly outstrips the value of honey and beeswax combined. As the human population worldwide continues to grow, the demand for pollinator dependant crops will continue to increase proportionally. It is safe to say that the disappearance of the honey bee would pose a global crisis for humanity.

In the past few years there has been a renewed buzz about the plight of the honey bee. A range of honey bee pests and diseases have recently become increasingly widespread, with populations in decline across Europe, America, and Asia. The rapid mortality of a colony is usually described as Colony Collapse Disorder, or CCD. This is a phenomenon where the adult population of a hive disappear or die. A range of possible causes for the current population failure have been proposed including pesticides, fungicides, selective breeding, and antibiotics, leading to an EU wide ban on pesticides. Despite this heightened research effort, scientists have not been able to identify a conclusive source of this decline in population.

Maximising the productivity of the existing honey bee population, as well as providing opportunities for growth in the face of spreading worldwide pests and diseases have now become hot topics for research around the world. My project aims to use "Wireless Sensor Network" (known as WSN) technology to remotely monitor the condition of beehives, in order to inform the beekeeper of the colony's status. In relation to diseases, this technology

can provide concrete evidence of the changes in the hive. If early evidence of disease can be detected, beekeepers can intervene earlier and thus improve the yield of their hives by lowering bee mortality.

Many great minds throughout history have been inspired by honey bees, from philosophers (Aristotle was one of the first to observe communication between honey bees, now known as the famous “waggle dance”), to scientists (Charles Darwin noted in *On the Origin of Species* that honey bees are “absolutely perfect in economising labour and wax.”), to writers (William Shakespeare compares a human monarchy with a beehive in *Henry V*, “Creatures that by a rule in nature teach/ The act of order to a peopled kingdom.”). This inspired the title of the project: a pun on the famous Shakespearean quote, “to be, or not to be?”.

Honey bees in Cork and Ireland

Ireland, and in particular Cork County, has a strong history relating to honey bees, with some of the oldest surviving documents describing the abundance of honey in ancient Ireland. A historic tradition of beekeeping is shown clearly in “An Bechbretha”, or “bee-judgements”, Irish Brehon laws (7th Century) relating to beekeeping, covering topics such as ownership of swarms, theft of bee hives, and neighbours’ entitlements to honey. The patron saint of beekeeping is Saint Gobnait, who is said to have cultivated bees in Ballyvourney, Co. Cork, where a shrine to her remains today (Fig. 1). One story tells of how she loosed her bees upon invaders to prevent them from stealing cattle. A stained glass window in the Honan Chapel in University College Cork depicts her surrounded by honey bees (Fig. 1). This strong history, as well as the continuing popularity of beekeeping in Ireland, makes Ireland an ideal location for tackling the global issues surrounding honey bees.

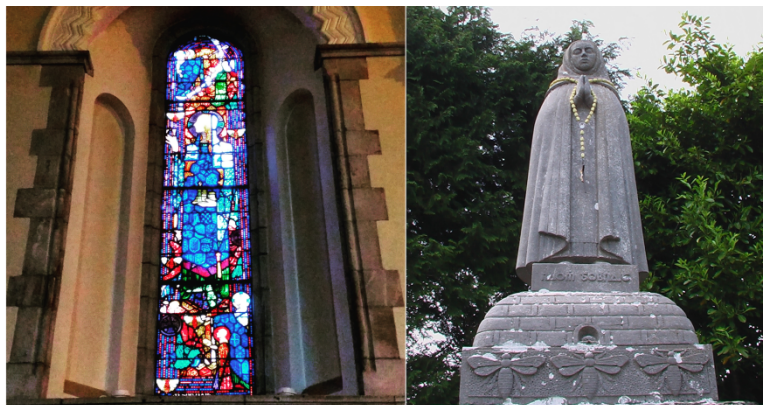

Figure 1: Saint Gobnait depicted in the Honan Chapel and at a shrine in Ballyvourney. Source: John Staats, Link: https://commons.wikimedia.org/wiki/File:Saint_Gobnait.jpg licensed under CC BY 3.0 <http://creativecommons.org/licenses/by/3.0/>

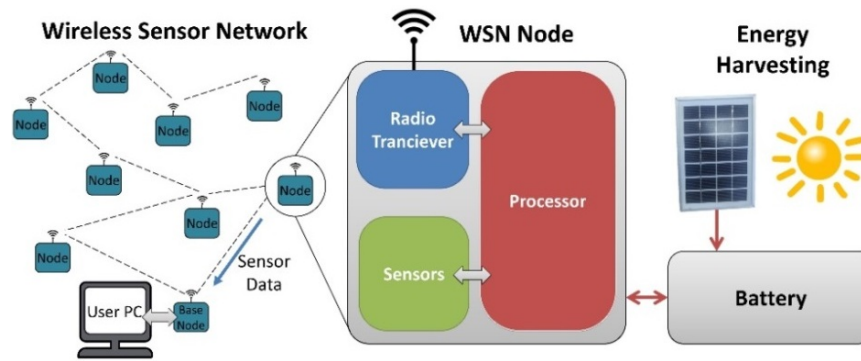

Figure 2: WSN operation. Source: Author

Boolean logic and bits

My project proposes to create a system for monitoring beehives remotely using wireless sensor networks, together with cloud storage and signal processing.

What are Wireless Sensor Networks?

Wireless Sensor Networks (WSN) is a unique technology which allows the user to gather data about physical or environmental parameters, often over a wide area, using a series of physically separate “nodes”. Each node is made up of one or more sensors (as the application requires); a battery or power supply; and a low power processor, which controls the node’s activity. The nodes are also enabled with wireless communication capabilities, allowing them to pass collected data to each other. This allows them to “funnel” all of the data to a single node for collection and analysis.

The operation and architecture of a WSN is described in Fig. 2. Applications of WSN include smart homes, security, video surveillance, industrial automation, and e-health. WSN is a vital technology for realising the emerging concept of the “Internet of Things” (IoT), a scenario where everyday objects are connected to the internet, allowing them to work together, tracking user requirements, improving accuracy, and reducing waste.

Boolean logic

WSN, like most modern communication technologies, utilises Boolean algebra at its very core. George Boole invented Boolean algebra and symbolic logic and is described as the ‘father of the information age’. He was appointed as the first Professor of Mathematics at UCC in 1849. In my project information from the bees is stored as Boolean “bits”. In fact the title of this article can be described technically to engineers and computer scientists entirely as a Boolean equation: $(2B)OR!(2B)=TRUE$.

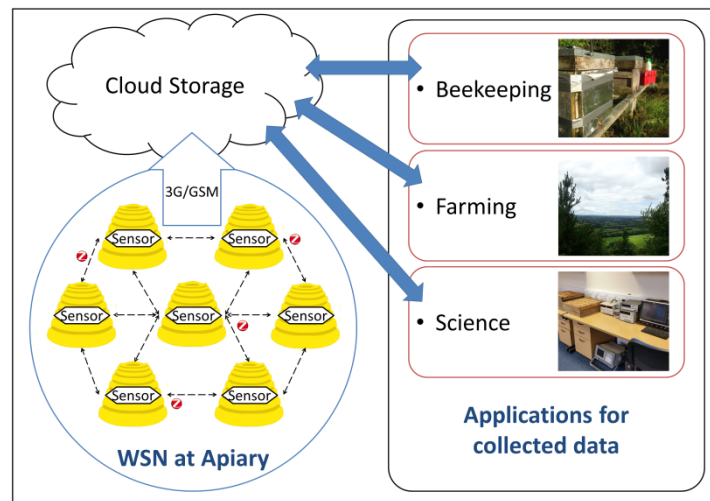

Figure 3: From the beehive to the cloud. Source: Author

The Smart Beehive project

My project places a series of wireless sensing devices, or “nodes”, within live beehives. These nodes gather data on several hive parameters which are important to the beekeeper for managing pests, disease, swarming and production. These parameters include CO₂ (carbon dioxide), O₂ (oxygen), pollutant gas levels, temperature, humidity, beehive weight, movement, sound levels, and bee imagery. These data are uploaded from the WSN to Cloud storage, where they can be processed and accessed by the beekeeper through a mobile device/PC. A diagram of how the envisioned system operates is shown in Fig. 3.

Several important features for the hive system were identified:

- Non-invasive, minimum impact on hive and honey bee colony. This is necessary to avoid a negative effect on colony health, production and size.
- Does not disturb/prevent typical beekeeper activities. The system must not impede regular inspection of the hive, and the beekeeper must have quick access to the hive in an emergency.
- Robust and resistant to hive conditions. The beehive is a hostile environment for electronics/batteries as it is hot and humid. Honey bees also cover anything within the hive for extended periods in propolis and/or wax, which could impact sensor readings.
- Low energy operation & energy harvesting. This allows extended deployments of the system.
- Suitable for remote deployment. Beehives and apiaries are often placed in isolated locations, and the design of the system needs to reflect this property.

The final smart hive design can be seen above in Fig. 4, the nodes are placed in the “lid”



Figure 4: Smart hive prototype and layout. Source: Author

of the hive so that they can be removed by the beekeeper when they want to inspect their bees in person. Placing the sensors inside the lid also allows them to effectively sample the airflow of the hive without being covered in wax, as the bees do not often enter the lid space. The data collected by the sensors are sent to the beekeeper, allowing them to view the conditions within the hive when they are unable to visit, such as during the winter, night time, or when the hive is in an extremely remote location. The sensor network uses a 3G radio (the same as in a modern smartphone) to send data to our storage servers and the beekeeper. This radio uses the existing mobile network to send data, without needing services such as a landline internet connection to every hive location. The prototype system shown was deployed on a live beehive during 2014 at an apiary near Banteer, Co. Cork, Ireland. Weather data for the duration of the deployment was obtained from Met Éireann to provide an extra dimension for analysis. The results of this deployment were vital in improving future versions of the system and developing automatic hive analysis systems described below.

Self-Sustainable operation

Just like every other electronic device, the smart hive requires power to operate. Obviously plugging the hive in is not an option when the hive is on the side of a mountain or in the middle of a forest. A battery would be able to power the hive for a while but would eventually run out. The beekeeper would then need to travel to every hive and replace the battery which defeats the purpose of remote data collection! To avoid this, a state known as “self-sustainable operation” needs to be achieved. This is where each node has a rechargeable battery together with “energy harvesting” devices, such as a solar panel or a wind turbine, to recharge it. Self-sustainable operation is achieved when the battery is regularly charged up by at least as much energy as the node uses in that period, meaning that the device effectively never runs out of power.

Solar panels have been successfully used in the initial deployment of the smart hive. This will be continued in the future deployments, together with a small wind turbine which

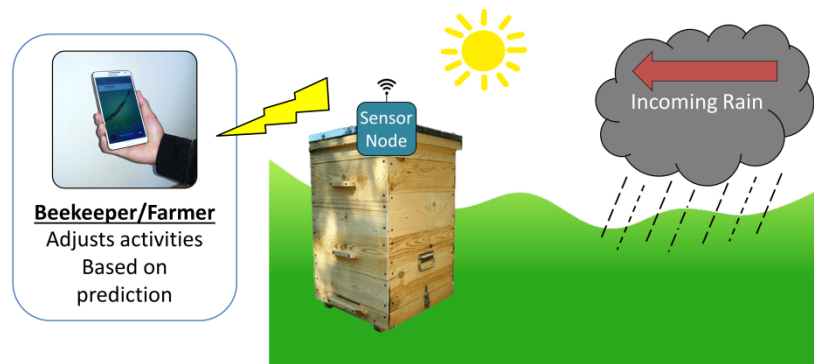

Figure 5: Predicting Irish weather, an “NBee Complete” challenge. Source: Author

will provide more energy during winter deployments. This is important because opening the hive to replace a battery, allowing cold air in to the hive, could be detrimental to the colony. More energy will also allow more data to be collected and stored, as each “bit” of information requires a certain amount of energy to collect, store, and send; and more information = more bits = more energy.

Information — The future of beekeeping

The main objective of this work from a beekeeping perspective is to provide an effective tool for high accuracy beehive management. A beekeeper that is well-informed about the status of their hives can apply their time and resources in a much more effective manner. In this way the smart hive can make beekeeping a more lucrative activity in the future. To ensure the smart hive has maximum effect, it is important that it can not only provide large amounts of raw data, but can extract information about the in hive activity and bring this information to the keeper’s attention.

One key engineering contribution of my work is in the area of machine learning, which is the development of algorithms which can extract information, make decisions, and make predictions based on data without the need for human intervention. Initially I have developed two machine learning algorithms, one of which can automatically describe the status of the hive (healthy, producing honey, hibernating, poorly ventilated, unwell/diminished population, or dead), based on this description the smart hive can select to send the beekeeper a text alert that the hive needs immediate attention. The second algorithm in development can accurately predict if there will be rain in the area local to the beehive in the next few hours, which has the potential to be a very useful tool for farmers as well as beekeepers.

I would like to thank my supervisors, Dr. Emanuel Popovici and Dr. Pádraig Whelan for their encouragement and support. I would also like to gratefully acknowledge funding provided by the Irish Research Council under their Government of Ireland Postgraduate Scholarship 2014 and UCC’s Strategic Research Fund. This project was awarded 1st prize in the IEEE /IBM Smarter Planet Challenge 2014.

The Mental Time Traveller: Considering the Future Consequences of Present Day Behaviours

Lisa Murphy

School of Applied Psychology, UCC

We must use time as a tool, not as a couch. (John F. Kennedy)

Time cannot be outwardly intuited. These are the words of Immanuel Kant, an 18th century philosopher renowned for his contemplations of the fundamental concepts underlying the entire human experience. Central to Kant's reasoning is the concept of subjective time, the idea that time is not only an entity to be quantified in the physical sciences, but a subjective experience which can differ across each person, rooting the individual in his or her own mental reality. We all have unique experiences of time. Two individuals can attend the same event, a concert or a party perhaps, and for one of them, time can move extremely quickly, but for the other it can drag on for what seems like an eternity. Time flies when we are having fun and enjoying ourselves, yet feels endless when we are bored or afraid. It is the lens through which we view and experience the world around us. We are constantly planning and organising our time; often making efforts to save, and sometimes deliberately waste this precious resource. Indeed, we speak more often about time than anything else there is to speak about; the word 'time' is most commonly used noun in the English language.

The experience of personal time is a fundamental component of conscious awareness. In the early 1980's, psychologists became fascinated with the cognitive abilities of an amnesic patient who had suffered a closed head injury. Although the individual did not exhibit impairment in the ability to recall the concept of chronological time, the units of time or how these units relate to each other, he demonstrated severe impairment in the awareness of subjective time, wherein the concepts of yesterday or tomorrow were perplexing and unknown. This highlights a fundamental distinction between the abstract knowledge of objective time, and the psychological perception and influence of subjective time. This distinction constitutes the basic premise on which temporal psychology originated.

Central to the field of temporal psychology are two important concepts which form the foundation on which my PhD research programme has been constructed: Time Orientation (TO) and Mental Time Travel (MTT). The concepts are inter-related in that both are concerned with the personal time experience of the individual and both can exert profound influences on decision-making as an individual goes about her or his daily life. It is also the case however that one is predominantly explored from a purely psychological

perspective, as a stable personality characteristic (TO), whereas the other is largely explored from a cognitive neuroscientific position, as a mental ability which is unique to human beings over other species (MTT). The overarching aim of my doctoral research is to explore the role of both concepts with regards to every day decision-making and behaviour. Specifically, my research focuses on decision-making around behaviours which could potentially impact our immediate or long term physical health such as cigarette smoking, excessive alcohol consumption and drug use (behaviours predominantly known as health risk behaviours), and regular exercise, healthy diet and seatbelt use (behaviours predominantly known as health protective behaviours).

Time orientation and health behaviours

Throughout our childhood, we begin to develop personality traits which ultimately become stable across individuals and across time. These personality characteristics form the very essence of who we are as individuals. They dictate how we behave towards others and how we will react and respond to certain stimuli or situations. An orientation towards a particular time frame is considered to be one important aspect of personality which develops throughout our childhood and becomes solidified as a stable personality characteristic according to our early experiences, our familial environment and other social experiences and interactions. It represents the level of cognitive involvement we devote to the past, the present and the future. When we make decisions as we go about our daily lives, most individuals exhibit a tendency to orient towards one particular time frame over the others to inform their decision-making. Consider the following scenario:

You are at a friends' party and somebody offers you a portion of your favourite dessert on a paper plate (for this example, let's say it is a slice of chocolate cake). You have already eaten a slice of the cake, along with some party finger food, and although you are not feeling too full or bloated, you know that it is probably not the best idea for you to eat another portion.

At this point, as the person who has offered you the cake awaits a response, most individuals engage in a quick decision-making process. Some may think back to a previous time when they overindulged, remembering the sensation of being over-full and sluggish. Others will only consider the immediate pleasure and gratification they will receive from eating another slice of double chocolate fudge. There are also those individuals who may envision the potential future consequences involved, e.g. feeling guilty or gaining weight.

This habitual gravitation towards considering past, present or future outcomes of a particular behaviour can exert a profound influence on our decision-making. The TO concept has been explored in studies across many different life domains (e.g. academic performance, career trajectories and financial management). However, my doctoral research is rooted in health psychology, and how TO can influence our engagement in health risk behaviours and health protective behaviours. To date, research suggests that an orientation

toward the present time frame is typically associated with engagement in health risk behaviours which are potentially damaging to physical health. Individuals who are present oriented are theorized to only consider the immediate consequences of their behaviours, thus engaging in behaviours which illicit and immediate reward (e.g. overindulging in sweet or fatty foods), over those behaviours which are associated more with long term gain (e.g. maintaining a balanced, healthy diet). Alternatively, an orientation to the future has been associated in the literature with maintaining a healthier lifestyle. Individuals who are future orientated have been found to be more likely to engage in behaviours which are protective of their physical health (e.g. regular exercise). Theoretically, this is due to their greater ability to plan, organise and work towards clear, specific goals, as well as their persistent regard for their continued health and safety or strive towards greater health and safety. However, it is also the case that the research to date has been limited in quality, producing a number of contradictory results, which renders the findings difficult to interpret and moreover difficult to apply to enhance or reduce engagement in particular health behaviours. Such limitations include:

1. Uniformity with regards to TO assessment: There is a lack of consistency within the field of health psychology with regards to the most appropriate means by which to assess an individuals' TO. As such, it is difficult to determine whether any contradicting findings are the results of such diverse measurement, or whether there are legitimate gaps in our theoretical understanding of the construct.
2. Research participants: The continuous use of student samples in research ultimately renders the findings only representative of the student population, and limits our ability to generalise research findings to other populations, e.g. older adults.

In order to address these limitations effectively, my PhD research programme incorporates the collection of data from a number of diverse populations, including adolescents and older adults, as well as the development of a new psychological measurement tool which to be used to assess TO specifically for research in health psychology and health behaviours. This will allow us to differentiate people according to their individual time orientations, and explore how this relates to the health behaviours that these individuals engage in. It is hoped that this measure will become the dominant means by which to assess TO specifically within health psychology.

Mental time travel

As our brain evolved, it developed a capacity that is unique to our species, a capacity whereby it can stretch weeks, months and even years into an infinite future, without us ever having to step outside our front doors. This ability is typically referred to in research as mental time travel (MTT). Although it involves the activation of many different regions within the brain, a crucial component involved in MTT lies right the centre, and it is called the hippocampus. This tiny structure is responsible for retrieving specific details,

thoughts and knowledge gained from our memories of past experiences, and using them to construct creative and scenarios in our minds, effectively allowing us to design our very own imagined future.

My PhD research also focuses on how we can harness this amazing ability, so that we can live longer and feel better while doing so. Imagine a moment of temptation, whether this is food temptation or a cigarette craving, the temptation to binge drink or to stay on that comfy couch watching endless hours of TV instead of getting some fresh air and exercise. These are the moments when MTT could be utilised to our advantage. If individuals could take a moment to not only consider, but to immerse themselves in an imagined future where they make the healthier choice and actively envision the associated benefits, it is likely that this process could result in changing one's behaviour for the better in the present. Likewise, vivid imagining of the adverse consequences associated with persistent unhealthy or risky behaviour may be an effective deterring factor for continued engagement in these kinds of behaviours. For my PhD research I am conducting a project which explores brain activation patterns involved in MTT using electroencephalograph EEG equipment. This equipment enables the detection of the location and magnitude of brain activity during specifically designed temporal tasks, i.e. participants will be asked to imagine themselves and others in past, present and future scenarios.

Research applications

Increased public spending on health care since the late 1990s indicates a growing awareness of societal challenges in physical health. However, despite decades of research in health psychology, we are still a long way from understanding exactly why it is that individuals continue to engage in or withdraw from behaviours which are known to directly affect physical health. The reasons underlying why some people persist in engaging in unhealthy behaviours despite being aware of the potential consequences are not fully recognised. Likewise, the reasons why some individuals (but not others) consistently engage in health protective behaviours and maintain a healthy lifestyle are not wholly understood. My PhD research posits that TO is a key explanatory factor in models of health behaviour. By testing associations between this concept and a variety of health behaviours, we can advance theory and understanding in health psychology, and employ this understanding to design low-cost educational and goal oriented intervention techniques. By devising strategies by which an orientation towards future thinking and imagined future consequences (specifically around health behaviours) can be increased, then more individuals will be successful in making healthier choices which will be beneficial for their long and short term physical health. Inventions designed around TO and MTT would therefore be constructed on the basis of a number of primary objectives:

1. To educate people on the power of MTT and future thinking,

2. To train individuals in techniques by which it can be actively applied and regularly practised in order to assist them in making healthier choices,
3. To reduce engagement in a health risk behaviour (e.g. overeating),
4. To enhance engagement in a health protective behaviour (e.g. regular exercise).

My research overall holds the potential for the incorporation of TO and MTT into specialised approaches to public health care, i.e. smoking cessation and other addiction treatment programmes, as well as for the development of mobile apps and self-help books. In particular, I am designing an online TO intervention, specifically tailored to smoking behaviour with the aim in assisting successful smoking cessation.

Understanding the role of TO and MTT in the subjective time experience and applying this understanding to facilitate behaviour change would hold immense implications for health psychology as a whole and for addressing societal challenges in health care and health protection.

I am a member of the BEATS Lab (Biology, Emotion and Transition Studies), the People and Technology Lab, and the Resilience and Transition Research Group in the School of Applied Psychology. I would like to thank my supervisors Dr Samantha Dockray, School of Applied Psychology, UCC and Dr. Audrey DunnGalvin, Department of Applied Psychology, UCC.

Rainbow of hope after the storm: Couples' experiences of pregnancy after stillbirth

Margaret M. Murphy

School of Nursing and Midwifery, UCC

“Hope” is the thing with feathers -
That perches in the soul -
And sings the tune without the words -
And never stops — at all -
EMILY DICKINSON

Pregnancy loss: a common and an underestimated event that has far reaching consequences

Despite phenomenal advances in maternity care over the past fifty years babies still die around the time of their birth and the causes may be varied. Pregnancy loss remains the most common complication of pregnancy today with one in five pregnancies ending in loss. These losses can occur at any stage from fertilisation through pregnancy to birth.

Stillbirth is when the baby, greater than 24 weeks gestation or weighing more than 500 grams, is born having never shown signs of life. Most of the estimated 2,000,000 stillbirths annually, happen in low and middle resource countries, and occur for a combination of reasons: lack of access to trained healthcare assistance around pregnancy and birth, poor nutrition, and a dearth of resources — to name but a few. Stillbirth remains an issue for high resource countries like Ireland also. In high resource countries, it is expected that one in two hundred pregnancies annually will end in stillbirth. Despite our best efforts these rates have remained static for the past ten years. On average there are three hundred and fifty stillbirths in Ireland every year. To put that into context that is a jumbo jet full of babies who never get to go home with their parents, who never get to fulfil their milestones, but these children are never forgotten about by their parents.

The veil of silence that surrounds stillbirth and its effect on couples

Loss and grief are universal issues, fundamental to the human experiences that affect us all at some point in our lives. Researchers have suggested that the loss of stillbirth is

unique. The idea of death occurring before birth is difficult to grasp as it challenges our preconceptions of a safe world order. There are few shared memories or tangible proof of the baby's existence. The baby has not lived outside its mother's body and is to an extent 'unknown' by others. Therefore this loss is often unrecognised or underappreciated by a couple's social support network or wider society and has been referred to by Cacciatore in 2013 as 'silent grief'. This lack of recognition can have devastating health and social consequences for couples including depression, post-traumatic stress disorder, complicated grief, and relationship breakdown. But in the midst of despair there is hope too, a high percentage of couples will go on to have another pregnancy, often very soon after their initial loss. Many women are pregnant again within twelve to eighteen months after their stillbirth. Being pregnant again can prove challenging for the women and their partners. They are attempting to bond with their new baby; while actively grieving for the baby they have lost. Previous research has highlighted mental health issues in the pregnancy after loss such as increased levels of stress, anxiety, depression, post-traumatic stress disorder and even attachment difficulties with the baby born after loss. While it is recognised that stillbirth can be experienced by same sex couples and by single women the inclusion criteria for my study is heterosexual couples. It is these couples and their experiences of pregnancy after loss, that are the focus of my research.

My research

My midwifery background, supporting women and their partners pregnant again after pregnancy loss, led me to my research question. The midwifery profession is very much grounded in clinical practice and the experiences of working, in partnership, with women and their families. Following a thorough literature search I was aware that the research on this area to date had a very pathological or illness focus. Midwifery, conversely, has a much more salutogenic or health focus with its theoretical foundations in the social model of pregnancy and birth. Salutogenesis was first described by the medical sociologist Aaron Antonovsky in 1979 and comes from the Latin *salus* (health) and the Greek *genesis* (origin). It is a theory that focuses upon factors that influence health and wellbeing rather than illness. Therefore I wished to apply a more unique and health focused approach to my research. I questioned if the act of getting pregnant again after loss was in itself a hopeful one. Therefore my research question became, 'what is it like for couples to experience pregnancy again after the experience of stillbirth?' To answer this question I have conducted extensive interviews with women who are pregnant after stillbirth and their partners.

Understanding couples' experiences of pregnancy after stillbirth

My research is unique as it is the first to examine the dynamics of couples as a unit or dyad in the face of pregnancy after loss in addition to its salutogenic perspective. Currently I am engaged in data analysis. Initial reading of the data has revealed the following: couples expressing the importance of having the challenges they face recognised, the importance of the provision of appropriate support and open communication, and that their deceased baby is honoured and acknowledged. Some tentative themes are emerging. Couples have reported wishing to honour the baby they have lost and the importance of protecting the time they see as 'theirs' (the deceased infants) before they can contemplate planning another pregnancy. The study offers new insights on how couples support and help one another through pregnancy after loss, in particular the unique role of fathers. Hope also appears to be present but without in depth analysis it is too early to speculate the role that it plays.

Potential impact

The potential impact of my research nationally and internationally is in its innovative focus on couples and on health rather than illness within this population. The practical application of my research will be in the development of concrete, supportive intervention protocols for women pregnant again after loss and their partners. These will help address many of the issues highlighted previously in the research such as stress, anxiety, difficulty in bonding and relationship issues.

"As long as we are being remembered, we remain alive" Carlos Ruiz Zafón

Margaret M. Murphy is a College Lecturer and a final year Doctor of Nursing student under the supervision of Dr Patricia Leahy-Warren, Senior Lecturer and Professor Eileen Savage, Head of School and Chair in Nursing, School of Nursing and Midwifery, Brookfield Health Sciences Complex, University College Cork, Ireland.

A special word of thanks to the couples who shared their stories so honestly and openly.

'Victor Hugo, the Irish 'Misérables, and Fenian women in the nineteenth-century'

Jeanna Ní Riordáin

Department of French, UCC

Introduction

When W.B. Yeats first met Maud Gonne, he told her of his ambition to be an 'Irish Victor Hugo.' Indeed the influence of France's greatest national poet on Yeats appears to have been profound and lasting. In his youth Yeats claims to have read Hugo's entire works, he quotes frequently from Hugo, and he spoke of Hugo at his meeting with the French poet Paul Verlaine in Paris. While the leader of French Romanticism no doubt very pleasingly appealed to Yeats' literary sensibilities, his political humanism, and his somewhat outlandish spiritual beliefs, the links between France's greatest national icon and Ireland are in fact far greater than has ever been acknowledged. This article seeks to explore Hugo's little-acknowledged, though decisive role as a spokesperson for the Irish 'Misérables' during the nineteenth-century. As well as examining Hugo's much-overlooked support for the plight of the Irish, this article will move on to explore the way in which Hugo's letter of support for the wives of Fenian prisoners is reflective of his wider support for the feminist movement in nineteenth-century. While existing critical appraisal on Hugo's feminism has been largely limited to his fictional representations of women, my research foregrounds the importance of Hugo's undocumented and unstudied primary material for evidence of his feminist convictions, as exemplified by his correspondence with Fenian women.

Hugo says the 'Ár nAthair.'

When Hugo declared his opposition to Louis Napoléon Bonaparte's 'coup d'état' in 1851, he was forced into political exile on the Channel Islands where he remained until his return to France following the foundation of the Third Republic in September 1870. Although expelled from his homeland and privately mourning the tragic death of his daughter, Hugo continued to exert a gigantic influence over affairs in France, and indeed the world. Far from enclosing him in a personal world of grief, desolation, and private despair, Hugo's experience of exile served only to make him more acutely sensitive to the plight of others, more vehement in his campaign for justice, equality, and an end to all forms of oppression. As a small nation in the throes of violent rebellion and upheaval, it is not surprising that Ireland should have resonated with Hugo's moral conscience and indeed as his many acute literary observations on Ireland indicate, he was just as sensitive to the plight of Ireland as

he was with that of the many other small nations which he defended during his prolonged political exile, most notably Crete, Geneva, Mexico, Portugal, Cuba, and Serbia. In his epic novel describing the ineluctable forces of social progress *Toilers of the Sea*, Hugo describes the Irish immigrants in London as the most wretched of all the 'Misérables' residing in the city: 'Living in wet clothing is a habit which may be acquired. The poor groups of Irish people, — old men, mothers, half naked girls and infants, — who spend the winter in the open air, in the snow and rain, huddled together at the corners of the London streets, live and die in this condition.' To use Jean-Paul Sartre's expression, Hugo was the epitome of the politically-engaged writer or 'l'écrivain engagé' who used his writing in such a way as to highlight the gravest social injustices of his time, whether it be the use of the death penalty, slavery, poverty, or prostitution. In the preface of *Autumn Leaves*, one of his finest poetic masterpieces, Hugo suggests 'a poetry working for the cause of liberty, a poetry for the people and against kings and all kinds of dictatorships.' The preface laments the bad state of affairs in Europe and Ireland is described as a cemetery. This metaphor is continued throughout the work wherein Hugo expresses his profound hatred for the oppression of small nations and evokes 'a bleeding Ireland expiring on its cross.' One of Hugo's most poignant literary references to the plight of the Irish appears in his novel *The Man who Laughs*, a tragic love story in which he launches a scathing attack against social inequality and injustice. In the novel, Hugo gives an account of a storm at sea in which a group of disenfranchised exiles among whom are Irish, French, and Basque women are united in prayer: 'Sanctificetur nomen tuum. Que votre nom soit sacrifié, dit le provençal. Naomhthar hainm, dit l'irlandaise. Adveniat regnum tuum, poursuit le docteur. Que votre règne arrive, dit le provençal. Tigeadh do rioghaehead, dit l'irlandaise.' Hugo describes how the Irish and Basque women, like all 'Misérables', are united not only through their language but also through their suffering: 'The motley nature of the group shone out. The women were of no age. A wandering life produces premature age, and indigence is made up of wrinkles. One of them was a Basque of the Dry-Ports. The other, with the large rosary, was an Irishwoman. They wore an air of indifference common to the wretched.'

From Fenian wives to Queen Victoria

While such poignant literary depictions of the 'wretched' Irish reveal his deep compassion for the Irish people and the sublime dignity which he bestows on all 'Misérables', Hugo's relationship with Ireland extended far beyond his literary expressions of sympathy when he became directly involved in the Irish political struggle. In 1867, while still in exile in Guernsey, Hugo received a letter from the wives of six condemned Fenian rebels seeking his support in their opposition to the impending executions of their husbands, among whom were the prominent leaders of the Fenian Rebellion of 1867, General Burke, Captain Mac Afferty, and Captain Mac Clure, and three others, Kelly, Joice, and Cullinane, who were each arrested and condemned to death by British authorities in the aftermath of the

Rebellion. Hugo's response to the women's plea for help was immediate and decisive, writing a personal letter to Queen Victoria seeking the reprieve of the condemned men, and cementing his role as a spokesperson for the Irish 'Misérables' of the nineteenth-century. In his letter, Hugo appeals to the renowned, global stature and reputation of England as an enlightened nation of progress, justice, and civilization. His letter is marked by a forceful, rhetorical tone in which he discredits the practice of capital punishment as an 'affront to civilisation' which contradicts England's role as a leading nation for all European nations. Hugo's decision to expressly address the letter to Queen Victoria in his attempt to grant clemency for the Irish rebels is particularly noteworthy in light of the fact that it was Hugo's support for a highly satirical article on Queen Victoria's visit to France in 1855 sent by his fellow French exiles to a London newspaper, which led to the expulsion of three French exiles from London, and subsequently Hugo's own expulsion from Jersey. Presumably, given their history, Queen Victoria would not have readily appreciated Hugo's input in an issue of such national concern and political import, yet Hugo's passionate appeal to Queen Victoria to spare the wives and children of the condemned men from social ruin remarkably succeeded in persuading her to grant clemency to each of the six rebels. On a further occasion in 1867, when three Fenians, the so-called 'Manchester Martyrs' were condemned to death after a police sergeant had been killed during a raid on a prison containing two Fenians, Hugo appealed once again for clemency from Queen Victoria. On this occasion however, Queen Victoria ignored Hugo's appeals for a reprieve and the three Fenians were hanged. On the following day, 24 November 1867, Hugo, deeply grieved by the incident, wrote in his manuscript: 'yesterday the three Fenians Larkin, Alton and Gould (the last two were in fact named Allen and O'Brien) were hanged at Manchester.'

The 'Don Juan' becomes a feminist

While Hugo's intervention in the plight of the Irish rebels confirms the lengths to which he went in support of the Irish 'Misérables' and the profound empathy he felt for their cause, his letter to the Fenian women is significant for another reason also. During his exile, Hugo became a spokesperson not only for the oppressed and downtrodden, he also became an international spokesperson in the struggle for women's rights and female emancipation. His participation in the feminist struggle of his time has been woefully overlooked however in the larger scheme of his social and political activism owing to the dominant critical focus on the more high-profile moral causes to which he devoted his attention, most notably, the abolition of the death penalty, an end to slavery, and the freedom of press. Then of course there is Hugo's enduring image as the most notorious 'Don Juan' of his time and the quintessential patriarch of the 19th century which has fuelled the scathing criticisms of his perceived one-dimensional image of femininity whereby women fit neatly into the categories of virginal girlhood or devoted motherhood, and which have made any claims to Hugo's feminism a seemingly implausible, and frankly unrewarding feat. While there are

many reasons why Hugo's contribution to the feminist movement of his time has not been deemed worthy of in-depth critical analysis, my research, which focuses on Hugo's largely undocumented letter correspondences with women during his time in exile and his primary discourse on women's rights breaks new ground in existing Hugolian scholarship by providing an invaluable insight into Hugo's direct participation in the struggle for female emancipation. These new insights cast Hugo's attitudes towards women in a revealing new light, while also offering new perspectives from which to view Hugo's representations of femininity in his fictional works. Over the course of his exile, Hugo received letters from countless groups of afflicted women as diverse as the female victims of the Cuban Revolution and the women at the forefront of the struggle against the introduction of regulated prostitution in England. In his letters of reply to these women, Hugo professes his upmost support for the most pressing demands of the feminist struggle in 19th century Europe. He condemns prostitution as a form of legal tyranny, and declares that a nation can never be free so long as half of its population are oppressed. His support for the women of Cuba and the Fenian women demonstrate his awareness of the changing position of women in the nineteenth-century, and his support for the pro-active, cross-gendered roles which women adopted in the various revolutionary struggles which unfolded during the century. He declared that the greatest achievement of the century would be the extension of equal rights to both sexes thereby completing the aims of the French Revolution. To that end, he argued that women were entitled to equal education, full citizenship, and equal suffrage rights — which were the most radical and defining demands of nineteenth-century feminism. Further, the feelings of displacement, isolation, and social alienation occasioned by Hugo's experience of exile enabled him to form a relational and experiential connection with the afflicted women who sought his assistance, and thus proved indispensable in enabling him to establish himself as a sympathetic voice in the struggle for women's rights. While the ability of men to engage in feminism is often treated with fear and suspicion owing to their privileged position as bearers of patriarchalism, Hugo's self-alignment with the plight of women on the basis of his own oppressed and marginalised status as an exile demonstrates his attempt to speak on behalf of women's rights, not from a privileged, masculinist perspective but from a compassionate and empathetic perspective, something which men involved in the feminist struggle today still struggle unsuccessfully to achieve. Such was Hugo's ability to harness the feelings of exclusion, marginality, and oppression occasioned by his experience of exile into an empathetic feminist voice that during his exile, his letter to the Cuban women was published in the *New York Times*, his progressive anti-prostitution discourse was alluded to in the *International Council of Women* in 1888, and Hugo was chosen as an honorary spokesperson for multiple feminist organisations and a political advocate for the improvement of women's rights in Parliament following his return to France in 1870.

An 'Irish Victor Hugo'

Aside from the many personal reasons why Yeats wished to be an 'Irish Victor Hugo', the deeply compassionate way in which Hugo supported and defended the small, anguished nation so beloved by Yeats more than vindicate this lofty aspiration. His direct involvement in the Irish political struggle make Ireland one of the many small nations whose freedom he advocated, and the Irish people yet another groups of voiceless, disenfranchised 'Misérables' whom he so valiantly defended. What's more, Hugo's response to the Fenian women's plea for help is a further poignant example of his much-overlooked though significant contribution to the feminist struggle of his time. In writing to Hugo, the Fenian women demonstrate the same 'profound respect' expressed by the many other groups of afflicted women who sought his assistance, while Hugo's deep compassion, solidarity, and decisive action on their behalf in turn reflects his conviction in fulfilling his own bold statement that the 'nineteenth-century would proclaim the rights of women.' While Hugo's defence of the Irish 'Misérables' has been greatly overlooked in comparison with his support for the afflicted nations in central and Eastern Europe and his renowned intervention in his campaign against the death penalty in North America, Hugo's primary discourse during his exile illustrates his direct intervention in the Irish political struggle. Further, Hugo's support for the Fenian women is illustrative of his largely unacknowledged though significant participation in the feminist struggle in the mid-nineteenth-century and the merit of investigating his neglected and forgotten primary material in bringing to light this aspect of his social activism, and his support for all oppressed people.

I would like to acknowledge the invaluable support, insight, and encouragement provided by my supervisor Dr. Paul Hegarty.

Photography: My New Score

Mary G. O'Brien

Department of Music, Sunday's Well., UCC

Introduction

The aim of this research is to demonstrate how photography is used as a creative tool in my compositional process. Purpose-built pictures are created solely with the goal of acting as musical scores, called graphic scores, from which performers improvise. This paves a way for me, the composer, to communicate my compositional ideas to the performers, resulting in new soundscapes and original artworks, without the restrictive barriers placed upon me, the composer, by convention.

As an artist, the objective is to capture unique moments in time, where images are taken naturally or by manipulating the camera in a variety of predetermined ways. This idea could work with any picture, but for me, it is the innate musical language that I have developed over the years of my conventional musical training, that leads me to the precise construction of these new compositions.

Inspiration

Initially, I was inspired by the writings of John Cage in his book *Silence* (1961), which helped to open my mind to the world around me. At the beginning of this research, I performed *4'33"* (John Cage) in various locations as I searched for musical inspiration and potential silence. I took photographs of these places as a record of this work.

"From nothing to something"

Later, as I visited art galleries around Europe, I discovered the black and white artworks of artists such as Robert Rauschenberg: the artist who inspired John Cage "to do for music, what he had already done for art". This led to my notion of working with "Nothing" the blank canvas, which became "Something" — a photograph, for example, thus triggering inspiration for creating new musical compositions.

Photography: My new process

Take this simple picture (fig.1) as an example: -



Figure 1: Dots and Lines Graphic Score — Source: Author

From this, I do not know the exact pitches the performers will play, but I know that I will hear a series of short notes from the performer of the blue dots, and a series of long notes from the player of the red lines. If I ask the performers to read from left to right, I have even more control. I could give precise performance instructions on some occasions, or alternatively, I could just hand the performers the picture to improvise on and we would discuss the implications of the performance thereafter. Both methods produce interesting results.

Therefore, as I design each picture, I have power over the density of the sound, known as ‘texture’ in the musical world. The picture can also be used to create a certain sense of mood using colour, and so on.

I discovered that displaying these photographs as part of my public performances of these pieces, gave a sense of space and meaning to the audience. This idea was inspired by CrossArt Ensemble: a group from Germany, who provided a concert and workshop to University College Cork music students in February 2013.

Rocky Bay string quartet

Capturing footage after a big winter storm in January 2014 provided a video of the waves hitting off the rocks, in Rocky Bay, Co Cork. I focused the camera on one rock for the duration of the video, with the help of my tripod. This created a still, but moving image, as the waves tossed and twirled around the space (fig. 2). As I recorded this footage, over a long period of time, I observed the natural soundscape of the area. This inspired me to compose a new piece for the Vanbrugh String Quartet, incorporating ideas devised from this picture. The stillness of the rocks, the violent movement of the water, and even a seagull jumping up and down to avoid the waves on a nearby rock, created the musical material needed to develop this piece.

To facilitate ease of reading, I recorded my thoughts on standard notation for these players. However, on this occasion, I also requested the musicians to improvise following coloured lines in the final section, as their sound represented the intensity of the storm. This piece was played at a University College Cork Workshop, with the video played at double and then quadruple speed behind them. The players were encouraged to watch this video as they sight-read the piece, creating interesting results.



Figure 2: Rocky Bay during a winter storm — Source: Author

Camera manipulation

Later, I decided that I should try to create some more unusual pictures, which I developed by manipulating the lighting and the shutter speed of the camera. These were designed with the intention of re-orchestrating my sound world to create a more ethereal quality, which could not have been achieved previously. Shaking the camera and capturing reflections, led to a series of photographs that would have been unimaginable at the initiation of this section of my thesis called *Darkness: Illuminations*.

Edinburgh lights: quiet music ensemble

Taking a trip to Edinburgh to capture the sounds of the zoo led to an interesting experience. Each night, I sat in the front seat on the second floor of a double decker bus on my return journey back to my hotel. Rather than wasting these precious moments, I set my camera to a long exposure mode. Using a slow shutter speed, I shook the camera resulting in unconventional shots. These pictures in turn became a slide show, which the members of the Quiet Music Ensemble (of which my supervisor Mr. John Godfrey is a part of) improvised on as part of another University College Cork student workshop. Each player was given a colour to follow on the screen. The results were ethereal in quality. This newly constructed score portrayed my intentions in an unprecedented way (fig. 3).

Edinburgh illuminations

“Edinburgh Illuminations” is a merging of photographs taken at a park of solar lights in Edinburgh City Centre during the same trip. I shook the camera in various ways and on some occasions pretended to trace letters in the air, whilst the camera was set at a slow shutter speed to produce the effects as can be seen in fig. 4 below. I extracted parts of each of these photographs and layered them together in Adobe Photoshop. At a recent concert called “It’s Not Just Black and White, Girl...”, part of Culture Night 2015, I asked



Figure 3: Edinburgh Lights: Camera Manipulation whilst sitting on a moving double-decker bus – Source: Author

the sound artist Harry Moore to improvise on this piece. He used a bow, some glasses, and other electronic devices to create the ethereal sound that I required for this piece.

Merged lights

“Edinburgh Illuminations” was performed concurrently with a piece called “Merged Lights” (fig. 5). This composition began in Crosshaven, Co. Cork, a year earlier when I spotted the reflection of the light in the water. I tried to capture the stillness of a boat with the moving water alongside it. Based on this experience, I became fascinated with capturing lights that occurred after dark. This included observing sunsets, the cloud formations passing in front of the moon, as well as reflections on the water, and man made electronic lights. Layering of these images captured in Ireland, England, Scotland and Wales, resulted in “Merged Lights” which was performed by another sound artist Danny McCarthy. These two pieces demonstrated to the audience how “Nothing” became “Something” as it evolved through time, media and space.

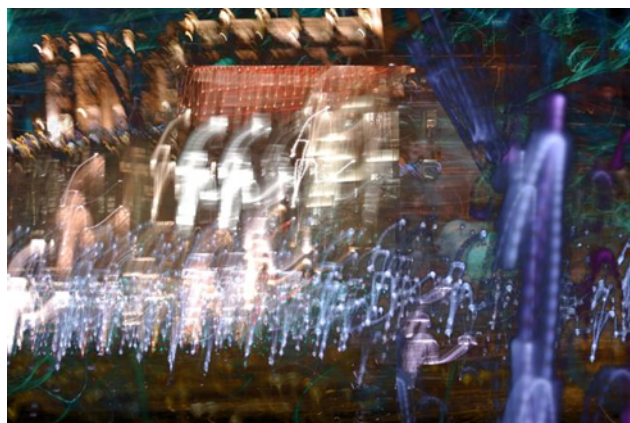

Figure 4: Edinburgh Illuminations: Merging several photographs taken as I manipulated the camera at a park of solar lights — Source: Author

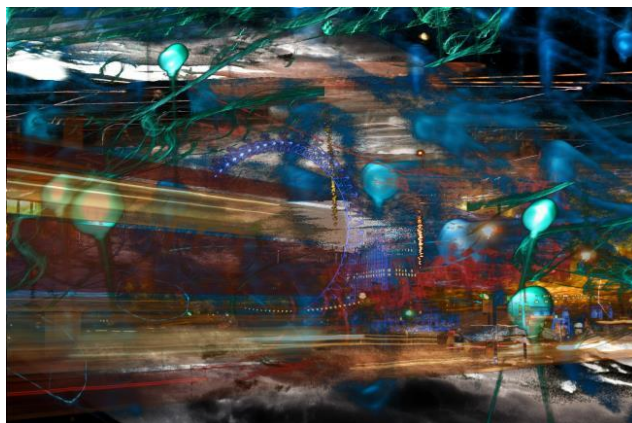

Figure 5: Merged Lights: Images from Ireland, England, Scotland and Wales unite as one — Source: Author

The Great Book of Ireland

Layering these photographs became a methodological feature of my work. In July, 2014, I decided to transfer this knowledge to the programme Adobe Audition as I began to sculpt my soundscapes as pictures. I used a series of sounds collected around Ireland for this project. I also recorded some “chance operations” using board games. I chose sounds that linked to the images that I saw when I looked at the Great Book of Ireland. I created sounds of someone making the book using wood, and even imitated John Cage’s voice reading, using a computer voice sound that I found on my laptop. I spoke the names of the artists involved and sang the final section. I added an extra layer that I created by hitting a large gate under the Music Department in Sunday’s Well using a contact mic to create a sense of importance to the piece. These sounds merged together as a twenty-layer piece to create my audio imagery that culminated in a performance called “Past. . . Future”, in the Glucksman Gallery, as part of the “Circus on the Great Book of Ireland”.

Reflections reflected on Jubilate Deo

The word “Reflections” aided a review of my earlier research and my methodological process of conveying my ideas to potential performers. It also gave me the opportunity to observe water and led to an interest in the collection of photographs of reflections.

This collection of pictures became part of an exhibition, held in the Unitarian Church, Princes Street, Cork in May 2015, but more importantly, the main picture became the trigger that inspired a new piece called “Reflections Reflected on Jubilate Deo” (fig. 6). This piece was originally written for three community choirs, one from the USA and two from Ireland. Later it was adapted for two community choirs and one organist. This piece received five public performances during the summer of 2015. One layer was based on the water, another on the trees and their reflection onto themselves and the third, the birds, flowers and bats that also appear in that picture.



Figure 6: Reflections Reflected on Jubilate Deo — Source: Author

Conclusion

The end result is a new methodological approach that evolves from a blank canvas, the “Nothing” to “Something”: a musical process, which uses photography and camera manipulation as a creative tool for composing new scores.

Special Thank You to my supervisor Mr John Godfrey and the Music Department, University College, Cork; Digital Media Department, Coláiste Stiofáin Naofa, Tramore Road, Cork; Crawford College of Art and Design and Cork College of Commerce.

A demanding form: William Faulkner and the short story

Eoin O' Callaghan

School of English, UCC

I'm a failed poet. Maybe every novelist wants to write poetry first, finds he can't, and then tries the short story, which is the most demanding form after poetry. And, failing at that, only then does he take up novel writing.

William Faulkner to Jean Stein, 1956

Introduction

Few authors have had such an impact on the American literary canon as the Southern novelist William Faulkner. His fiction of four decades not only constitutes an extensive exploration of Southern people and their environment, but represents a study of universal human tragedies and moral struggles. The zenith of Faulkner's career was his receipt, in 1949, of the Nobel Prize for Literature. Faulkner outlined, in his acceptance address, his belief in the endurance of man and the potential of writing to help him prevail. In particular, he advocated a return to what he perceived to be the principal theme of writing: the problems of the human heart in conflict with itself. His receipt of the award was naturally a turning point in his lengthy career. Its prestige and promise of financial security helped to ameliorate his financial struggles and to cement his position as an American master of letters.

Some details of Faulkner's early artistic forays are worth mentioning here. Following a short-lived career as a poet in the 1920s, Faulkner began a fortuitous sojourn in New Orleans with the established author, Sherwood Anderson. Anderson encouraged Faulkner to draw upon his own experiences in small-town Mississippi and to incorporate his Southern background into his fiction, which Faulkner did in his creation of Yoknapatawpha County. Yoknapatawpha is a fictional locality partially modelled on Faulkner's home county of Lafayette, but it is simultaneously an imaginative playground in which Faulkner is able to dexterously direct characters from novel to novel. Yoknapatawpha is the setting for many of Faulkner's most acclaimed novels and short stories of the 1930s. Faulkner was, however, and by all accounts, contrary in his opinions of Yoknapatawpha, holding an ambivalent view of its relative importance in his work.

Faulkner's opacity on this particular subject is not unusual. Faulkner sometimes claimed that his Southern characters acted autonomously and that he would merely walk along behind them to note down what happened. On other occasions, he fully embraced his

self-proclaimed role as sole owner and proprietor of Yoknapatawpha County, free to summon or instruct any character as he required. Scholars have therefore been forced to negotiate a tangled web of remarks and interpretations in order to deduce his true feelings on a given subject. Faulkner's attitude to his short stories has been particularly difficult to circumscribe, and a definitive theory of Faulkner's short fiction has thus far eluded scholars. In the course of this essay, and in my wider research, I aim to determine Faulkner's working philosophy of the short story and to establish whether his recommendations for the short story genre are in fact reflected in his body of short fiction. Faulkner's short stories have been ill-treated in the field of Faulkner criticism, with only a handful of critics completing full-length studies of the short fiction. Short story theory in general has only recently begun to generate a large amount of scholarship, and it has deemed Faulkner to be of little consequence in the genre. My research, therefore, also seeks to challenge and change the relative neglect of the short story work in Faulkner Studies.

His canon

Despite his habitual insistence that he had failed at writing in the short story form, taking recourse, instead, in the novel, Faulkner in fact managed to achieve varying degrees of success in both genres throughout his career. Like many of his American coevals, including Ernest Hemingway and F. Scott Fitzgerald, Faulkner spent a considerable portion of his career writing short stories, producing at least 100 works of short fiction. Roughly 70 of these stories were published in his lifetime and several others, which he had been unable to sell to literary magazines or include in collections, were published posthumously by his chief biographer in 1979. Many of his most impressive stories were also written during his most productive novel-writing period; indeed, these stories contain, and perhaps enable, an even more dazzling panoply of genres and settings than his boldly experimental novels of the 1930s. Such a feat, however, has not been widely recognised or accepted by scholars and critics.

Faulkner's career as a short story writer can broadly be categorised according to three phases. During his apprenticeship to Sherwood Anderson and alongside the publication of his early novels in the late 1920s, Faulkner drafted several stories which he recuperated for publication late in his career. Many of Faulkner's unpublished stories also date from this period. Faulkner's second phase, bookended approximately by the years 1930 and 1938, saw the author write and publish the majority of his short fiction. His most famous and most anthologised stories also date from this phase. His final phase begins in 1938 and extends, effectively, until his death in 1962. During this phase, Faulkner at last acquired the financial independence and celebrity status which reduced his reliance on writing stories for literary magazines. He did, however, incorporate several older stories into new novels and short story collections. Faulkner's short story career, as a whole, can be described as circular in form: in his later years, Faulkner returned to many of the episodes, characters and ideas with which he had begun his fiction.

His comments

Faulkner himself reserved a high degree of praise for the short story in his intermittent musings on literary form. He apparently considered the short story to be a challenging, precise art form that required as much skill and economy of language as poetry. He suggested, on more than one occasion, that the short story demands an “absolute exactitude” while the novel, by contrast, permits the author to be “slovenly and careless.” He maintained this admiration for the short story form long after he had ceased to write extensively in the genre, judging by his letters and lectures in the latter stages of his career. Writing to Joan Williams, a would-be student and mistress of Faulkner’s in the 1950s, Faulkner declared that the short story was “a crystallised instant” and that, next to poetry, it was “the hardest art form.” Despite his more gruelling experiences selling stories in the 1930s, then, which will be addressed in detail below, Faulkner’s opinion of the short story remained essentially positive.

It should be remembered that, in spite of his respect for the short story genre, Faulkner considered it to be beyond his powers as a writer. In fact, Faulkner, who was known for his self-deprecating manner, seems particularly critical and querulous with regards to his skills as a short story writer. In 1928, he confessed his belief that he had “no talent” for short stories, and that he persevered in submitting magazines to literary magazines with “unflinching optimism”—if little confidence. He also admitted in 1948 that he had never written a short story that he liked. Perhaps the negative reception which the short stories have received has been partly fuelled by Faulkner’s own reservations about the short story work. Such misgivings on Faulkner’s part only increased in frequency during the 1930s.

His career

Largely consistent throughout Faulkner’s correspondence with his agents and editors in the 1930s is his belief that short stories, much like his purgatorial years writing screenplays in Hollywood, were his best means of generating income. In the 1930s, Faulkner had not yet achieved widespread critical success, with the majority of his books then out of print, but at least a degree of commercial success could be secured by publishing stories in literary magazines—even if Faulkner disliked the idea of supposedly prostituting himself. In 1932, Faulkner compared the process to “go[ing] whoring,” indicating his increasingly desperate attempts to attract literary magazines by writing popular pieces that would sell quickly. In 1939, Faulkner wrote to Random House describing his struggles to pay his bills by writing short stories, and complaining that he would have to “hammer out another one.”

Despite the fact that Faulkner often remarked upon this throwaway quality of his short story work and his ability to churn out stories at will, in actuality, it was not possible for Faulkner to compose stories at such a pace—due not only to the standards and stipulations of contemporary magazines, but also due to his own fastidiousness. Such perfectionism

meant that many of Faulkner's short stories, and particularly those which were later re-worked for incorporation into novels and short story collections, underwent significant revision prior to their appearance in literary publications and in book form. Faulkner obviously could not, without a certain modicum of inspiration, produce a short story on demand, even joking on one occasion that he would try to "get hold of one of the magazines and take a story that they will buy and change locale and names, etc." He even recognised that his need for money hindered his writing ability. He lamented in 1939 that his financial struggles had forced him to write "mechanical stories in which [he] had no faith."

One reason for the neglect of Faulkner's short stories is the argument that Faulkner's motivation for writing his stories was financial and not aesthetic—an opinion which would appear to be supported by Faulkner's cavalier attitude towards his magazine publications. Faulkner, too, was not above manipulating his work if he thought that alterations would help the story to secure a higher price in a magazine. This is despite his continued insistence that the short story was a carefully crafted form. However, it should be remembered that Faulkner was not alone among his contemporaries in publishing short stories to financial novels, F. Scott Fitzgerald being the best-known example. Furthermore, even if Faulkner did consider the short story to be his best means of generating money, such a feat does not negate his artistic achievements in the form and his success in developing a diverse range of stories. His substantial revisions to stories like "Lizards in Jamshyd's Courtyard," of which there are at least a dozen different manuscript and typescript versions, suggests his dedication to perfecting his material. In the majority of cases, these changes were not precipitated by the recommendations of magazine editors.

His contributions

The defining aspect of the short story is, of course, its brevity, and a reading at one-sitting criterion has been embraced, for the most part, since the inception of the short story and of short story theory in the writing of Edgar Allan Poe. Faulkner theorised that the best short stories were those of three thousand words or less and did not categorise much of his own work as short stories for this reason. During his time lecturing at the University of Virginia, Faulkner emphasised that reducing a story to three thousand words was a talent he did not possess. Expert craftsmen like Chekhov could tell a story in two thousand words, but lesser craftsmen, such as Faulkner himself, would require eighty thousand words. Many of Faulkner's most famous stories fail to follow this rule of thumb and are sometimes judged as novellas or short novels. His long stories are symptomatic of his distinctively inclusive writing style, often using multiple adjectives where only one is required.

But throughout his career, Faulkner consistently displays his flexibility with the form and length of the short story. For example, Faulkner was able to reduce an unfinished novel manuscript, known as *Father Abraham* and totalling roughly fifteen thousand words, to a

lean eight thousand for its publication as the story "Spotted Horses." He was then able to extend and develop this story again for its inclusion in a late, three-volume work known as the Snopes Trilogy.

I propose that Faulkner's primary contribution to the development of the short story as a genre lies here—in his perceptive understanding of the relationship between short and novel forms. Short stories such as "Spotted Horses" are independent, autonomous units which can be enjoyed and understood by themselves. However, Faulkner realised that his short stories could gain new significance when incorporated into longer pieces of work. For the Snopes Trilogy, Faulkner combined a number of short stories which he had written and sold throughout the twenties and thirties. These stories, once integrated into the fabric of the Snopes novels, become episodes which lend thematic and structural unity to the trilogy. Faulkner may even have felt that to rework these stories would be to salvage material that he had written for financial reasons and to manipulate them for artistic purposes.

Conclusion

While Faulkner was ostensibly an accomplished short story writer and held a great admiration for the form, the novel undoubtedly remained his preferred form—his reputation is, after all, primarily based on his experimental novels. It is even likely that Faulkner enjoyed reading novels rather than short stories, and when questioned on multiple occasions about his favourite writers, he rarely mentioned short story authors. I argue, however, that Faulkner remained optimistic about the short story throughout his career, ranking it second only to poetry. Any disregard which Faulkner appears to demonstrate for the short story can be explained by the fact that his experience of writing short stories was often coloured by financial struggle. I suggest that the care with which Faulkner revised his stories—and particularly the collection or novels into which they were woven—is testament to his almost boundless capacity and propensity for rewriting and adapting his short fiction. Faulkner's key contribution to the development of a short story as a form lies his keen understanding of its relationship to the novel, or of the potential relationship short stories might bear to each other in the context of a longer work.

I wish to acknowledge the help and support of my supervisor, Professor Lee Jenkins. I would also like to thank the Irish Research Council, the UCC Strategic Research Fund and the School of CACSSS for providing funding during my research.

Nutrition and Health in Mothers and Infants — Update from the Vitamin D Research Group

Karen O’Callaghan

School of Food and Nutritional Sciences, UCC

Maternal Nutrition

Nutrition plays an important role during all stages of the life cycle, from maternal health during pregnancy to healthy ageing in later life. Evidence suggests that a woman’s diet during her pregnancy can not only have a substantial effect on the health of the growing baby, but is also related to a variety of health outcomes throughout childhood and even into adulthood. Put simply, by optimising the dietary intake of the expectant mother, we can help provide her child with a healthy start in life.

Since maternal nutrition at conception and throughout pregnancy directly influences the growth and development of her child, this provides a unique opportunity for health professionals to encourage women to make sensible dietary choices that will be of benefit to both themselves and their baby. Women are often motivated to improve their dietary and lifestyle behaviours at the beginning of pregnancy for the simple reason of wanting to deliver a healthy baby. It is therefore prudent that accurate, up-to-date information concerning nutrition and lifestyle behaviours is available to all pregnant women, in order to encourage women to make informed, conscious choices both peri and postnatally. Policy makers rely on the work of scientific researchers to provide the evidence that will guide recommendations for public health. High quality research studies are central for determining nutritional adequacy and are pivotal to the development of lifestyle intervention programmes that can positively impact the health of current and future generations.

Beginning at conception, the key “window of opportunity” continues at least throughout the first two years of a child’s life. Pregnancy is a time of increased nutritional demand. The extra requirement for certain nutrients, specifically iron and folic acid, has been the focus of perinatal research for many years, and vitamin D has recently attracted much attention. However, despite the sudden growth in the scientific exploration of vitamin D and health, particularly regarding early life nutrition, dietary vitamin D requirements in pregnancy remain unknown.

The Vitamin D Focus

The vitamin D status of the new-born infant is completely dependent on that of the expectant mother and so it is essential that women are nutritionally adequate during pregnancy. The term deficiency is based upon a biomarker of vitamin D status in blood serum. Vitamin D must reach a certain level in blood in order to prevent any symptoms of deficiency, but it is not yet known how much vitamin D pregnant women must consume to reach this specific threshold. My research aims to address this knowledge gap.

Sources

Commonly referred to as the “sunshine vitamin”, vitamin D can be obtained from both dietary sources and from sunlight. Vitamin D is found naturally in few foods throughout the food supply, often in limited concentrations, and so dietary vitamin D intakes are typically low. Sunlight, therefore, is the most significant source of vitamin D for humans. Vitamin D production is stimulated through the action of ultraviolet B (UVB) radiation on the skin's surface, and subsequently stored within the body's adipose tissue (fat stores). The body can then draw upon this stored vitamin D when dietary supply and/or sunlight is limited. This becomes important during the winter months when the sunlight deficit results in inadequate vitamin D production. However, vitamin D synthesis is affected by several environmental factors, including latitude and cloud cover, which reduce the strength of the sun on the skin's surface and prevent vitamin D production. The combination of a poor dietary vitamin D intake and the typical ‘Irish summer’ mean that many of us are described as having a poor vitamin D status.

Functions

Vitamin D is both a nutrient and a hormone precursor. That is, it acts as a hormone within the body. Vitamin D is activated by specific enzymes in two consecutive reactions called ‘hydroxylation’, which refers to the addition of a water molecule during the activation process. In order to function as a hormone, vitamin D binds to what are known as ‘vitamin D receptors’ that are located in the body's tissues. Vitamin D receptors have long been found in skeletal tissue; however, the presence of such receptors in the placenta reveals a specific role for vitamin D in pregnancy.

The most well-defined role for vitamin D is in the regulation of calcium metabolism, where vitamin D helps increase calcium absorption. When vitamin D intake is low, it can have a significant impact on bone health, leading to osteomalacia (softening of the bones) in adults and rickets in children. Rickets itself was once thought to be a disorder of the past, yet case reports from both Western and non-Western hospitals suggest that it is now making a comeback. Vitamin D-deficiency rickets is a disorder of the growth plate, resulting in bone anomalies and growth retardation in children. Children often present

with muscle weakness and pain, or 'bowed legs' in severe cases. The bones are unable to fuse properly and so the knees turn outwards, giving a bow-like appearance to the legs. In the Western world, rickets is seen most often in children of a darker skin colour, where a low dietary vitamin D intake is coupled with inadequate production from UVB rays. Skin exposure to sunlight is limited by certain cultural and religious clothing practices, which can place some dark-skinned women and their children in the 'at-risk' group for low vitamin D status. Vitamin D-deficiency rickets is a nutritionally preventable disorder, and so its reoccurrence thus reflects the inadequacies in nutritional intake worldwide.

The prevention of rickets parallels the prevention of infant hypocalcaemia, where insufficient calcium status occurs due to inadequate intake or inhibition of absorption resulting from very low vitamin D status. Hypocalcaemia is a potentially life-threatening disorder, causing changes in heart beat and seizures in extreme cases. The dual role of vitamin D and calcium is therefore central to gestational health. There are, however, many other potential mechanisms by which vitamin D may influence maternal and fetal health, and results from vitamin D supplementation trials often support the relationship between maternal vitamin D intake and improved neonatal birth weight, length and growth during infancy. Emerging evidence also suggests a link between vitamin D deficiency at birth and childhood infectious diseases, cognitive disorders and long-term heart health, though the data is somewhat inconsistent.

Requirements

In Ireland, where the long winter and often cloud-covered summer is unable to compensate for an inadequate dietary vitamin D intake, supplemental vitamin D can contribute largely to overall vitamin D status. The question is, how much is enough?

"The most dangerous phrase in the English language is: We've always done it this way".

Rear Admiral Grace Hopper

In 2011, the Institute of Medicine issued a report which stated that the dietary vitamin D recommendations for pregnancy were to remain the same as for women who are not pregnant, on the basis that there was "insufficient evidence" to support otherwise. So although the beneficial effect of vitamin D during pregnancy has been extensively described, a lack of substantial scientific data exists on which to base dietary advice.

Current Studies – My Research

My research focuses on the importance of maternal nutrition during pregnancy with a strong emphasis on the role of vitamin D. I am currently working as part of the Vitamin D Research Group in UCC, where I am the co-investigator of a nutrition-based study that

aims to guide vitamin D recommendations for pregnant women, both in Ireland and internationally. This study, known as the DMAT Study, forms part of a large collaborative project called ODIN, led by Prof Mairéad Kiely and Prof Kevin Cashman. The objective of ODIN is to establish food-based solutions for the eradication of vitamin D deficiency. DMAT is a double-blind, randomised controlled trial of vitamin D versus placebo. In simple terms, this means that participants in the study will be assigned (or randomised) to one of three doses of supplemental vitamin D and asked to take one supplement each day from the beginning to the end of their pregnancy. The supplements provided will contain either an active or inactive (placebo) form of the vitamin. The given doses of vitamin D are completely safe, similar to what would be found in a commercial vitamin D supplement or multivitamin. Hence, no risks are foreseen in this trial. Double-blind simply means that neither the participant nor the investigators will be aware of the dose to which the subject has been allocated. This is a preventative measure to ensure that any results or trial outcomes cannot be affected by bias from those involved in the study. This study will examine blood vitamin D levels of the participants throughout pregnancy, accounting for vitamin D intake from both habitual food choices and sun exposure. By comparing serum (blood) vitamin D levels of those consuming the highest amount of vitamin D to those in the lower categories, we will be able to estimate the correct dose of vitamin D needed by a woman each day throughout her pregnancy to ensure that both mother and infant are considered “vitamin D sufficient”.

My work on this study will form the basis of my PhD where the primary objective will be to provide the evidence to guide dietary vitamin D recommendations during pregnancy. A secondary aim of my research is to use novel techniques to track measurements of arterial stiffness and blood pressure throughout pregnancy which I hope will add a piece to the complex puzzle that is pregnancy-related hypertension. Ultimately, my work will focus on modifiable nutritional and lifestyle factors that can lead to a healthier mother and baby.

DMAT is currently taking place in UCC, in conjunction with INFANT (Irish Centre for Fetal and Neonatal Translational Research) at Cork University Maternity Hospital, and will continue to recruit participants for a minimum of one year. By conducting this trial over a 12 month period, we can ensure that any variability in seasonal sun exposure (which influences vitamin D status) is accounted for. We hope to recruit approximately 200 women from the Cork area, who will be followed from early to late gestation. Participant inclusion is driven by the desire of women to have a comprehensive, informed understanding of the dietary behaviours that will influence the health of their children. INFANT, which is a world-leading perinatal research centre and the first of its kind in Ireland, allows for high quality maternal and child research studies to take place here in Cork, which can help improve pregnancy outcomes at the national and international level.

“No amount of funding or resources can make up for a lack of volunteers”.

-NHS ‘Why We Do Research’ Campaign

Maternal nutrition is at the heart of the health of future generations. Diet is a modifiable lifestyle factor; supplementation can work provided women remain compliant with supplement use. However, dietary recommendations need to be established based upon sound, scientific data from quality-led clinical trials. By focusing on research in early life, we can provide the evidence to help policy makers implement public health strategies that will positively affect the lives of women and children for years to come.

Karen O' Callaghan is a PhD candidate in the School of Food and Nutritional Sciences under the supervision of Professor Mairéad Kiely. The author wishes to acknowledge funding from the European Commission 7th Framework Programme and to thank the DMAT Study team and all participants of the DMAT Study.

Marginalised Texts: The Old English Marginalia and the *Old English Bede* in Cambridge, Corpus Christi College 41.

Patricia O Connor

Digital Arts and Humanities and the School of English, UCC

Introduction

Bede was a prolific writer in Anglo-Saxon England who, over the course of his prodigious literary career, produced a diverse range of Latin texts encompassing educational and scientific treatises as well as Biblical commentaries. Out of all his Latin works, Bede's *Historia Ecclesiastica Gentes Anglorum* (*The Ecclesiastical History of the English People*) is regarded as his greatest achievement, as it provides significant insights into a largely undocumented period in English history. The *Historia Ecclesiastica* was translated into the vernacular sometime in the late ninth or early tenth century and this translation is commonly referred to as the *Old English Bede*. The *Old English Bede* survives in five extant manuscripts, dating from the mid tenth and late eleventh century: Oxford, Bodleian Library, Tanner 10; London, British Library, Cotton Otho B. xi; Oxford, Corpus Christi College, 279; Cambridge, University Library Kk. 3.18 and Cambridge, Corpus Christi College, 41, the last of which is the focus of this article.

Cambridge, Corpus Christi College, 41 is dated to the first half of the eleventh century and is distinguished from its fellow *Old English Bede* manuscript witnesses by the extensive number of Old English and Latin texts that are written into its margins. I have provided an image of a page from Cambridge, Corpus Christi College, 41 which illustrates how extensive these marginal texts, which will henceforth be referred to under the collective term marginalia, are in this manuscript.

It is clear from the image in Figure 1 that the scribe responsible for these marginal texts made very effective use of the manuscript's spacious margins. Here on p.196 the text of an Old English wisdom poem *Solomon and Saturn* occupies the manuscript's upper, outer and bottom margins, completely surrounding this section of the *Old English Bede*. My work aims to explore how the Old English marginalia influences and affects our reading of the *Old English Bede* by reading the Old English marginalia in relation to their physical and thematic relationship to the body text, in order to arrive at a more informed understanding of the possible purpose of these marginal texts. The objective of my research is to argue against the idea that the physical relationship between the marginalia and the *Old English Bede* is coincidental and to assert the possibility that these marginal texts may have been

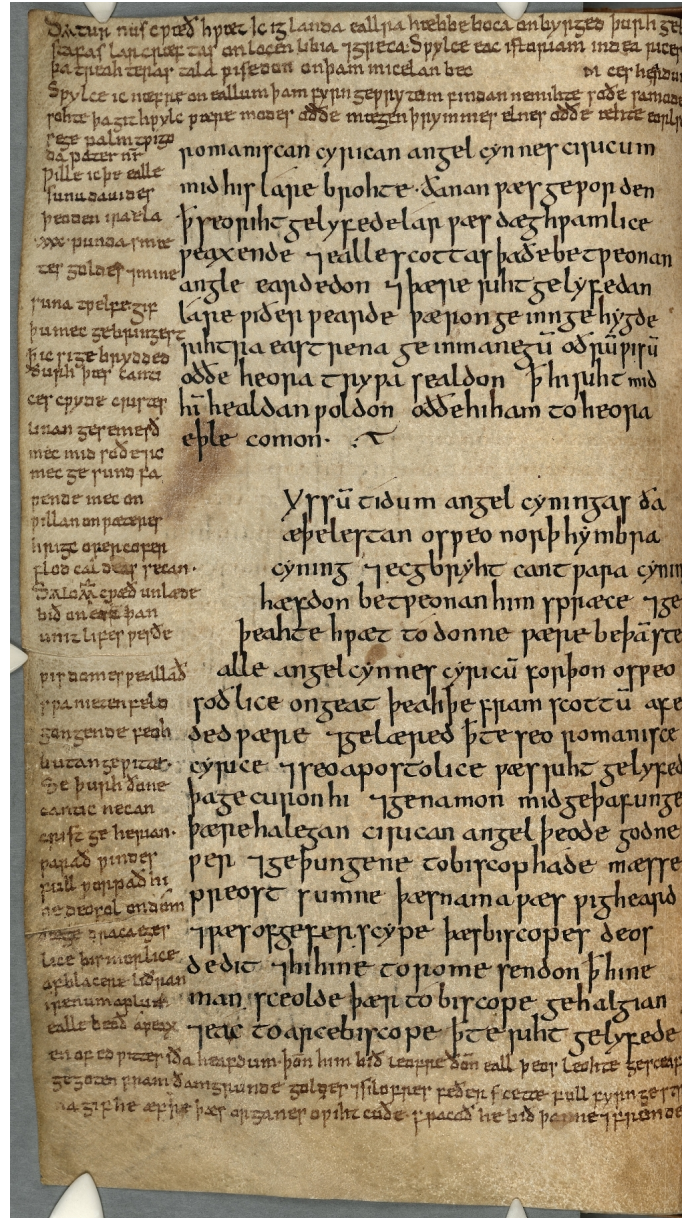

Figure 1: The Old English wisdom poem *Solomon and Saturn*, CCC MS 41, p. 196. Reproduced with permission from the Master and Fellows of Corpus Christi College, Cambridge.

meant as intentional textual additions to the passages of the *Old English Bede* they are written beside. This reconsideration of the marginalia will be an important contribution to the study of Old English literature as it will be the first all-inclusive reading of Cambridge, Corpus Christi College 41 which incorporates both the principal text and the marginal Old English texts that were copied after the *Old English Bede*'s completion. Reconciling the marginalia with the principal text will yield new insights into the *Old English Bede* and into the marginal texts themselves, as this will be the first time that the manuscript's internal textual relationships will be fully acknowledged and addressed.

What Have Charms Got To Do With The *Old English Bede*?

A charm is generally understood as a device that is used to produce a desired result through the solicitation of non-human intervention, be it via magical means or divine intervention. The word charm conjures up associations with the linguistic fallacy of magic, the notion that words can have a tangible effect on the real world. This tangible effect was achieved through a chant or incantation which was often spoken in the vernacular or in Latin and appealed to Christ, the cross or other saints.

The Old English charms found in Cambridge, Corpus Christi College 41's spacious margins continue to excite scholarly discussion because of their seemingly incongruous relationship with the *Old English Bede*. The charms within Cambridge, Corpus Christi College 41 form a curious mix, being comprised of a charm to pacify a swarm of bees, three charms to use in the event that goods or livestock are stolen, and a *Journey Charm*. The concise instructions of the charm to tame a swarm of bees, commonly referred to as the Bee Charm, direct the reader or practitioner through a two-step ritual and vernacular incantation that seeks to subdue a swarm of bees. The next charms that the reader encounters in a linear reading of the manuscript are the three charms concerned with stolen possessions or livestock and are collectively known as the Cattle Theft Charms; these charms address the issue of stolen livestock or property to varying degrees. The first two Cattle Theft Charms have more of a focus on recovering the stolen cattle or revealing the location of the stolen cattle, while the final charm places a stronger emphasis on the punishment of the thief. Each of the Cattle Theft Charms achieves its desired result through incorporating a Latin incantation that appeals to Christ, the cross of Christ and certain saints. The final and longest charm written into the manuscript, the *Journey Charm*, implores supplication from Christ and the Apostles for personal protection throughout the duration of a person's life. What, then, does such an eclectic collection of charms have to do with Bede's *Ecclesiastical History of the English People*? By reassessing each charm's individual manuscript context my work will not only provide a more informed insight into the charms' textual relationship with the *Old English Bede*, but will also provide interesting insights into how and why these charms were used in Anglo-Saxon England.

Martyrs In The Margins: The Old English Martyrology In The Old English Bede.

The *Old English Martyrology* provides the earliest vernacular account of martyrs venerated by the Christian faith. Organised according to the Christian calendar, the *Old English Martyrology* not only identifies the saint's feast day but supplements the anniversary by adding historical information about their lives including details about their miraculous works and their martyrdom. The *Old English Martyrology* was a text of considerable evangelical and pedagogical import as it was primarily used to inform its readers about the cults of local

and foreign saints. Unfortunately, despite its obvious educational value, the *Old English Martyrology* has not survived in its entirety, but was reconstructed from its four fragmentary manuscript witnesses, one of them being Cambridge, Corpus Christi College 41.

Cambridge, Corpus Christi College 41 preserves the shortest extract from the *Old English Martyrology* which includes brief notices on the Birth of Christ, St Anastasia, St Eufemia, St Stephen, St John the Evangelist, The Holy Innocents and an incomplete account of St Silvester within the *Old English Bede*'s ample margins. In spite of the brevity of these notices, this small fragment in Cambridge, Corpus Christi College 41 is invaluable as it is the only manuscript containing this part of the *Old English Martyrology*, specifically the feast day notices for 25th – 31st December. My research endeavours to examine the impact this invaluable portion of the *Old English Martyrology* has on our reading of the sections of the *Old English Bede* it accompanies and determine whether this short sequence has any thematic and contextual relevance to the *Old English Bede*.

Is There Anything To Be Said For...Adding Another Homily?

The six Old English homiletic texts preserved in this remarkable manuscript consider a number of important events and figures from the Bible that would have interested and appealed to an Anglo-Saxon audience, and include:

1. A dialogue concerning the body between the soul and God on Judgement Day
2. An account of the Assumption of the Holy Virgin
3. Judgement Day
4. The Harrowing of Hell for Easter Day
5. A homily describing the various roles attributed to St Michael
6. A homily on the Passion of Christ.

What is interesting about this selection of homilies is that practically all of them can be classified as examples of apocryphal literature, which is essentially literature that contains material that is not derived from the Bible.

Interestingly, like the *Old English Martyrology*, the majority of the homilies are only preserved in Cambridge, Corpus Christi College 41. Indeed out of the six homilies listed above only the first and fourth homilies can be traced to different manuscripts. The uncanonical content of the Assumption of the Holy Virgin, Judgement Day, St Michael and the Passion homilies may be one reason why they are found in no other manuscript in the Old English corpus.

The primary objective in studying these apocryphal homilies is to investigate whether there are any conclusive thematic or contextual connections to the sections of the *Old English Bede* that they accompany. Their inclusion within the *Old English Bede* may have

been intended to offer more insight into the place and function of apocryphal homilies within the church and more specifically, within an evangelising environment. In the late ninth and early tenth century Bede's *Historia Ecclesiastica* was translated into Old English to make this important text more accessible to a wider audience. In a similar vein one could reasonably conjecture that rendering these homiletic texts into the vernacular made homiletic literature more accessible for the lay community.

It could also be argued that the apocryphal elements within these homilies could have performed a similar function as the heterodox material would have been more effective in edifying the laity. This is reasonably well-founded as apocryphal texts enjoyed a wide circulation throughout Anglo-Saxon England at this time. Interpreting these marginal homilies in relation to their placement within the *Old English Bede* will help to establish the influence and utility of these homilies within the Anglo-Saxon Church.

Unlike today, the classification of literature was less rigid in medieval culture, it is probable that for some clergy members these apocryphal homilies may have been useful evangelical tools and as such that these marginal homilies were considered as practical and welcome additions to the *Old English Bede*.

Conclusion

Ultimately my research proposes to adopt a more inclusive framework for interpreting the *Old English Bede*, which is in favour of including the marginal texts in our reading of Cambridge, Corpus Christi College 41. This holistic style of reading the *Old English Bede* will provide an innovative insight into the early medieval textual culture that not only produced Cambridge, Corpus Christi College 41, but read, studied and added to this manuscript as well.

My research will differ from previous research on Cambridge, Corpus Christi College 41 as it will seek to reconcile the marginalia with the Old English Bede; this has not been attempted in the standard edition of the *Old English Bede* produced by Thomas Miller. Although Miller recognised the significance of the Latin and Old English marginalia, he did not address the marginalia's relationship with the principal text. In his edition of the *Old English Bede* the marginalia is isolated; removed from the chapters it accompanies in the Bede and placed in his commentary alongside the other variants of the *Old English Bede*. Miller's decision reflects modern linear reading practices and is a direct consequence of prevailing editorial norms.

The approach that underlines my research however is grounded in an appreciation of the variances that characterised manuscript culture. Consequently, this study has encouraged a renewed appreciation of Cambridge, Corpus Christi College 41's assorted manuscript context by demonstrating the cultural and thematic insights that are to be gained through a holistic reading of the manuscript. When considering a manuscript containing as diverse

a collection of charms, martyrologies and homilies as Cambridge, Corpus Christi College 41, it is important to note that Anglo-Saxon compilers may not have shared our present preoccupation to compartmentalise texts and perhaps possessed a different rationale for recording these seemingly disparate texts together alongside the *Old English Bede*. Adhering to modern reading and publishing practices in studying this early medieval manuscript increases the likelihood that the rationale behind these curious reading and scribal practices will remain obscure.

The scope of my research is presently limited to the relationship between the Old English marginalia and the sections of the *Old English Bede* that they accompany. I have yet to determine the possibility of similar thematic and contextual correspondences existing between the Latin marginalia and the *Old English Bede* within Cambridge, Corpus Christi College 41. There is much to be gained from future research focusing on an all-inclusive reassessment of the intriguing relationships inherent in Cambridge, Corpus Christi College 41, as this different perspective would greatly enhance our understanding of the textual world of the *Old English Bede*.

With gratitude to my supervisors Dr. Thomas Birkett and Dr. Orla Murphy.

Why is the Shaky Bridge so Shaky?

Deirdre O'Donnell

Civil and Environmental Engineering, School of Engineering, UCC

“The Shaky Bridge. Officially the shakiest bridge in Ireland”.

This is the claim of a poster ad campaign for Murphy's Stout, and it demonstrates the legendary status attached to Cork's most famous and most loved dynamic structure.

History of Structure

There are only three suspension bridges in Ireland; at Birr and Kinnitty Castles, both in Co. Offaly, and Cork's own Daly's Bridge. The 87m meter long steel suspension bridge spans the River Lee, shown in Figure 1, connecting the Mardyke and Sunday's Well areas just east of Cork city centre. Constructed in 1926 to replace a ferry crossing at the location, it was manufactured by David Rowell & Co. Ltd. of London to the specifications of then Cork City engineer Stephen William Farrington. Named Daly's Bridge for James Daly, a wealthy benefactor of the project, today it is better known locally as 'The Shaky Bridge' for its perceived 'shakiness'.



Figure 1: Daly's Bridge, River Lee, Cork. Source: Author

Despite being renowned for its dynamic nature, very little work has been done to investigate the reason for or the degree of lively behaviour for this historic steel structure. According to local knowledge, some refurbishment work was undertaken in the 1980s, which involved replacement of the timber walkway and which residents say reduced the level of movement in the bridge. Some improvements were also made to the steel parapets and towers, and this can be seen by the varying degrees of degradation in an otherwise homogenous material.

Structural Health Monitoring

“The process of implementing a damage identification strategy for aerospace, civil and mechanical engineering infrastructure is referred to as structural health monitoring (SHM).”-“The fundamental axioms of SHM”, *Worden et al (2007)*

The monitoring of structures in order to assess their capacity to fulfil their intended purpose has been taking place to some extent as long as structures have existed, but the formalisation of this field into a branch of engineering in its own right has truly come to prominence in recent years. It has become so well established that there now exist ‘axioms’ of SHM; fundamental truths on which a process can be implemented. It can also be summarised as a four step process:

1. The identification of damage existence
2. The determination of damage location
3. The identification of the damage type
4. The determination of the damage severity

Structural Health Monitoring (SHM) involves the monitoring of bridges and other structures over time, with the aim of identifying the presence, location and extent of damage with a final view to predicting the lifespan of the structure. SHM focuses on developing technologies and systems that assess integrity of structures such as buildings, bridges, aero-space structures and off-shore oil rigs. SHM systems can be employed in design validation, detection of damage or deterioration, safety assessment, instruction on prioritisation of repair and maintenance, evaluating repair works or simply to add to the knowledge base of the broader engineering field. So while this project focuses on Daly’s Bridge, it also aims to outline a method that can be used to assess similar structures, while contributing to the knowledge base for this growing field of engineering.

Perceptibility of Motion to Pedestrians

Many footbridges are slender structures with natural frequencies (that is, the frequency at which the structure will vibrate without external forces) that often lie in the domain of the dominant frequencies of walking pedestrians. Naturally the most frequent and often dominant dynamic load for a footbridge is pedestrians walking. It is believed that excessive vibrations in footbridges are caused by near resonance of one or more modes of vibration due to the similarity of the pedestrians’ footsteps and the bridge’s natural frequency.

Pedestrian forcing can lead to vibrations, both laterally and vertically, that are perceptible and sometimes uncomfortable to humans. It is an issue of serviceability that has come under much interest recently, due to high profile cases such as the Millennium Bridge in London. This bridge had to be closed to the public shortly after its official opening,

as the crowds of pedestrians had an unanticipated effect on the bridge, causing extreme motions which many felt was unsafe. There exist solutions for when vibrations fall outside of the range of acceptability; in the case of the Millennium Bridge, it was retrofitted with tuned mass dampers and fluid viscous dampers which, respectively dealt with vertical and horizontal movement by absorbing the vibrations. The lack of design codes, the standards engineers must adhere to when designing a structure, to address this issue of serviceability led to this mishap and this problem is becoming recognised as an important one. Works investigating the effects of pedestrians on dynamic structures, like the Millennium Bridge and Daly's Bridge, are becoming more popular and such investigations forward the cause of standard implementation in industry.

Methodology

This project aimed to investigate the dynamic behaviour of Daly's Bridge and assess its structural health, as neither had been done before. Finite element modelling and instrumentation were two tools chosen to do this, which would complement each other and lead to a more holistic understanding of the structure.

For this project, as the first of its kind to be undertaken on this historic structure, we had to gather information from a variety of sources, old and new. When it became clear that no detailed drawings of the bridge were available, a survey to obtain all geometric data of the bridge had to be conducted which then allowed a 3D drawing to be created in the computer-aided design software AutoCAD. A visual inspection of each member of the structure for damage and corrosion was also carried out, and the members deemed structurally redundant, so damaged that they no longer held structural qualities, were systematically recorded. The material of the bridge was found to be steel, from an archived bill of quantities dating back to the time of construction. This document also helped in understanding the components used to connect different member of the bridge to one another, like the 8 sockets which anchored the cables to the ground.

Finite Element Model

In order to assess the vibration characteristics of the structure a finite element model was then constructed (Figure 4). This computer model was created using Strand 7 software, and it is a full geometric representation of the bridge, with each member assigned the appropriate material properties of steel and the connections between members were designed to represent the real, physical connections on the bridge. The damaged members, identified in the visual inspection, which included some members of the handrails and towers, were removed from the model for a more realistic representation. Changes were also made to the properties of steel used, in order to match the results of the model to the results from the testing of the as-built condition of the bridge, discussed below.

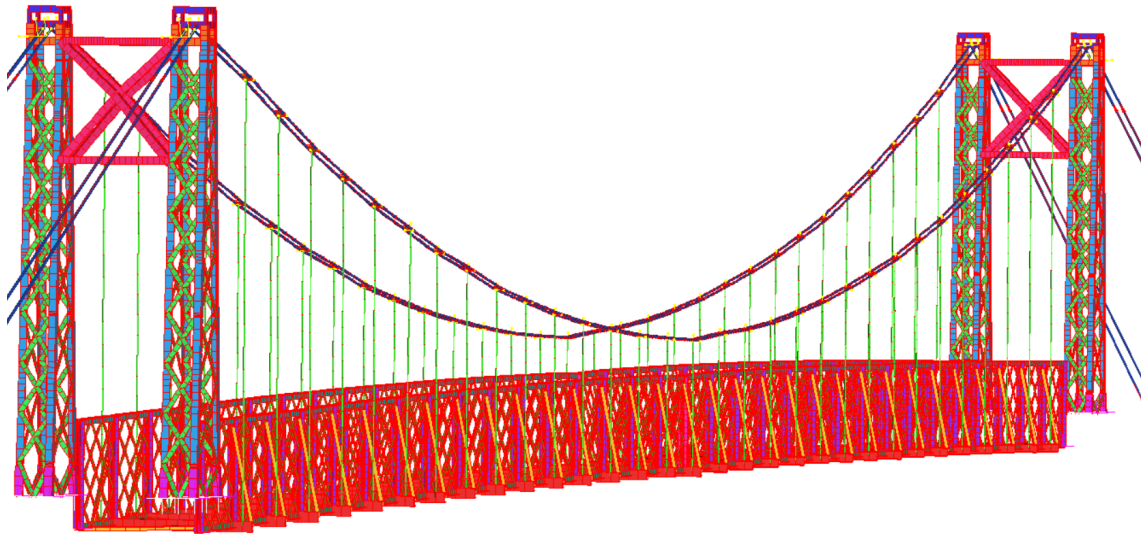

Figure 2: Detailed finite element model of Daly's Bridge. Source: Author

Dynamic Testing

With a model in place, a testing scheme was designed in order to get information about the bridge's behaviour for a range of excitations. Eight accelerometers were attached to the bridge at various positions along its span and on different structural components; one was placed on the cables at the centre span, another on the wooden walkway at the quarter span. These accelerometers recorded vertical accelerations of the structure over two hours. It was observed in its ambient position when no pedestrians were present, and for a range of controlled and uncontrolled pedestrian traffic, including individual walkers, groups of walkers and a lone cyclist. From this data, the velocity of the motion and the frequency of the motion could also be derived. This information was indicative of the structures behaviour and the reasons for that behaviour, and it also allowed comparisons to be made with the finite element model, which in turn had its accuracy improved to better represent the in situ condition of the bridge.

Results

The set of data from the days testing was analysed in order to assess, compare and rank, in terms of human comfort level, the response of the bridge to different excitation sources.

First, the acceleration is a key factor in what humans can perceive from a moving structure. The acceleration data for the periods of time where specific activity occurred on the bridge were extracted from the full data set, and these data sets were also analysed in terms of their frequency; this data is presented in Table 1. The acceleration recorded for a group of pedestrians traversing the bridge was the highest, and this matched observations made of the structure. Interestingly, a lone cyclist crossing the bridge barely excited the bridge

Table 1: 1: Accelerations & Frequencies of bridge under different excitations

Excitation Source	RMS Acceleration (m/s ²)	Peak Frequency (Hz)
Ambient Excitation (at rest)	.036	2.265
Cyclist	.048	-
Controlled Pedestrian 1	.11	1.64
Controlled Pedestrian 2	.38	2.25
Group of Pedestrians	.51	1.9 — 2.2

beyond the rest condition; due to the full contact between the bicycle and the walkway there was no impact loading, to which the bridge is notably sensitive.

In the comparisons of the natural frequency of the bridge, shown in Table 1 as the peak frequency under ambient excitation, and the forced frequency of pedestrians, the values are similar. The cases where the frequencies of excitation source and structure are closest, the highest amplitudes of acceleration were recorded.

In order to contextualize the data in terms of human perceptibility, we surveyed pedestrians as they crossed the bridge on the day of testing. They were asked to rank the motion of the bridge as one of the following; imperceptible, barely perceptible, distinctly perceptible, strongly perceptible or disagreeable. The majority ranked the bridge's motion as 'strongly perceptible', with people who often used the bridge noting that the response depends on the number and the pace of the users of the bridge at any given time, and the results of our testing corroborated this.

Finally, the matching of outputs of the finite element model to the actual responses of the bridge recorded during experimentation lead to a more realistic representation of the structure in its true condition. This matching is an important part of many structural health monitoring applications, as an accurate computer model can be used as a base line for assess future changes in the bridge, and assess the effect such damage might have on the structure, globally.

Conclusion

The matching of walker and bridge frequencies causes a resonance condition, which amplifies the motion of the bridge. Many 'Corkonians' and UCC students are familiar with the Shaky Bridge, and this investigation into its shakiness has offered insights into the reasons for its dynamic behaviour. The motion ranks as 'strongly perceptible' on the scale of human perception, and while a system of dampers could be implemented to reduce this motion, it would be expensive and ultimately unnecessary. With the locals' fondness for the Shaky Bridge as it currently stands, I'm sure Cork would have it no other way.

Thanks to my project partner Robert Wright and my supervisor Dr. Vikram Pakrashi.

The Medieval World on the Renaissance Stage

Meadhbh O'Halloran

School of English , UCC

“I know the present only through the television screen, whereas I have direct knowledge of the Middle Ages”. (Umberto Eco)

Introduction

Christopher Marlowe (1564-1593) was an Elizabethan playwright, poet and translator, and also an exact contemporary of William Shakespeare. Marlowe was the first to develop the blank verse format for which Shakespeare would become famous. Marlowe's promising career abruptly ended with his sudden, violent death at the age of 29. Soon after, Shakespeare achieved his first successes on the London stage. Understandably, Marlowe's work has often been considered in relation to his famous successor, and many conspiracy theories propose that Shakespeare *was* Marlowe. In the popular 1998 film *Shakespeare in Love*, Shakespeare gets his best lines from Marlowe, and this is how Marlowe is perceived: as Shakespeare's predecessor and influence, with his own work a secondary consideration. My thesis aims to shift the focus back onto Marlowe's canon. When his work is studied in its own right, Marlowe's influences are classical texts and contemporary humanist discourse. Instead of studying what developed from Marlowe, or his contemporary influences, I examine Marlowe's use of earlier material: medieval literature.



Figure 1: A portrait thought to be of Marlowe. Commons licensed image from http://commons.wikimedia.org/wiki/File:Christopher_Marlowe.jpg

What exactly is “medieval” literature?

No era has consistently captured the imagination like the medieval period. From *Lord of the Rings* to *Game of Thrones*, we often see the medieval world re-imagined in the contemporary image. This long tradition of depicting the Middle Ages began immediately after its end, in the Renaissance or early modern period. Marlowe's society held a continued fascination with their recent past. The “medieval” period is open to debate, generally it is classified as the “middle” period between the late antique period and the Renaissance, circa 800-1400 A.D. The term “Medieval literature” encompasses a wide spectrum of material, not just literary tales but plays, oral tales, historical texts and learned manuscripts on various topics. Most of these texts such as history plays, courtly romance tales and religious theatre, remained familiar to every section of the population. Tales still familiar in the twenty-first century such as *Robin Hood* were extant, alongside similar heroic such as *Bevis of Hampton*, *Guy of Warwick* and *Huon of Bordeaux*. What is significant about these tales was their multi-genre format: they appeared in various forms of print, from expensive hard-bound tale collections to cheap pamphlets, in plays and in songs. As large sections of the population remained illiterate, oral readings were commonplace. These tales circulated throughout English society, and formed part of the shared consciousness of the population. Though the Elizabethan era was an extremely innovative period for English drama, these medieval formats reappeared on the stage. English theatre began as religious performance to embellish church services, but developed into a shared cultural experience. Marlowe's hometown of Canterbury was a hub of street theatre throughout his early years, and travelling “chapmen” sold cheap storybooks throughout the country.

Medieval narrative in the Early Modern Era

What is remarkable about the survival of medieval literary forms in Marlowe's lifetime is the fact they survived at all. Literary trends are products of social change, and the greatest upheaval occurred in the post-Reformation period. The Reformation affected not only religious matters but every aspect of society. As Queen Elizabeth sought to establish a Protestant kingdom, any reference to Catholicism was outlawed. As many popular tales pertained to the adventures of Catholic saints, whole swathes of literature became taboo. Publications underwent strict censorship, as every text was required to promote the new Protestant ideology. Literature was not simply utilised as a source of entertainment, but for instruction of the reader in appropriate behaviour. The new Protestant church sought to encourage, and enforce, conformity wherever possible.

Within the Universities, medieval literature was also under attack. Humanist scholars claimed a “rediscovery” of the classical past, and sought to emphasise their own innovations by denouncing popular literature as frivolous and crude. Yet old habits die hard and the general population continued to read their favourite familiar stories in their increasingly unstable world.

Unsurprisingly, religious drama was also outlawed. This left a considerable gap in the cultural life of the country. Theatre moved from civic to commercial, where previously performances were funded by guilds and aristocratic patrons, now they were produced by private enterprises for a paying audience. It was in this new industry that Marlowe would make his name.

A playwright could expect a potential audience to have a shared understanding of an array of plots, stock characters and literary forms. Just as satirists rely on their audience's prior knowledge, a common understanding between author and audience can be utilised in the creation of new material.

Marlowe's Re-Imagining of Medieval Literature

In the immediate post-Reformation period, readers and audiences expected the narratives they would encounter to uphold religious and social norms. Although contemporary writers denied the omnipresence of medieval tropes and themes in the early modern period, it is this very pervasiveness that renders medieval literature ripe for re-invention. Marlowe re-imagines medieval forms by redefining them. He reworks medieval history in *Edward II* to destabilise the audience's belief in the concept of the divine right of kings. In his play *The Jew of Malta* Marlowe presents an apparently stereotypical villain, only to use the stock medieval characteristics to invite the audience to sympathise with the Jew. Marlowe sets up generic expectations only to flout them. This creates a disorientating effect which encourages his audience to think critically and question, rather than blindly accept, the status quo. During an era of strict censorship, subtly displacing the expectations of the audience allows Marlowe to probe established belief systems from a safe distance.

Conclusion

Medieval literary tropes and themes retained their currency in early modern England, and were continuously used by authors. Marlowe's use of the earlier material is unique and challenging to his audience, encouraging free-thinking during a period of major religious, political and social upheaval. In essence, my research will identify Marlowe's use of medieval literary material and demonstrate the importance of this within Marlowe's literary corpus. Marlowe scholarship suffers from an over-emphasis on his most accomplished play, *Doctor Faustus*, and has been dominated by biographical readings of his work which examine a literary figure first, and his work second. My thesis serves to redress this balance, it is an entirely new reading of Marlowe's work which moves away from these well-trodden paths. It illustrates the enduring and important legacy of medieval literature in later periods, and offers a new reading of a canonical author, and a more nuanced conception of the period that produced such innovative drama.

With thanks to my supervisors Dr. Edel Semple, Dr. Andrew King and Prof. Lee Jenkins. My research is generously supported by a School of English Postgraduate Studentship.

Technology and Teenagers: No Time to Sleep?

Siobhán O’Neill

School of Applied Psychology, UCC

Sleep is that golden chain that ties health and our bodies together. (Thomas Dekker)

The “lazy teenager”

It’s 7am on Tuesday morning and your alarm is blaring beside you. You feel groggy and disoriented and you know you have to get up but you hit the snooze button instead, unable to motivate yourself to get up. Twenty minutes later your mother comes into your room to wake you for school, you’re going to be late again. You struggle out of bed to the words, “You’re so lazy! What time did you go to sleep last night? You need to go to bed earlier.” Once at school you go through the motions of classes, breaks and socialising. However, as the day goes on you find yourself getting sleepier and sleepier, unable to fully concentrate on the teachers or even your friends. You wish it were Saturday already so you can get that much needed lie in. But Saturday feels like such a long way away with a week full of school, homework, football training and your part-time job to get through first. Maybe your Mum is right, you’re just lazy and need to go to sleep early tonight.

We’ve all heard the term “teenagers are lazy”, we’ve probably even been called lazy ourselves at some point during our adolescence. There is a stereotypical notion that teenagers will stay in bed all day and sleep if they were left to because they are lazy. What if I told you that this stereotype is misleading and unfair? What if I told you that teenagers can’t help wanting to stay in bed until mid-morning or later? Well it’s true.

During puberty the body goes through biological changes that affect the sleep hormone melatonin, causing it to be secreted later in the evening. Melatonin determines sleep onset and is regulated by light. As the day goes on, light starts to fade and melatonin begins to be produced by the body, it reaches peak secretion levels in the middle of the night and then declines to low levels in the day. (See Figure 1 below). In adolescence, melatonin is secreted later meaning that sleep onset shifts to a more evening preference and a later bedtime, and so teenagers are biologically predisposed to stay awake later at night.

Although adolescents go to bed later at night due to these biological changes, their daily schedules are still dictated by societal norms. For instance school start times are scheduled for the early morning and in many instances second level schools start earlier than primary schools. These early mornings conflict heavily with the biological clocks of teenagers and

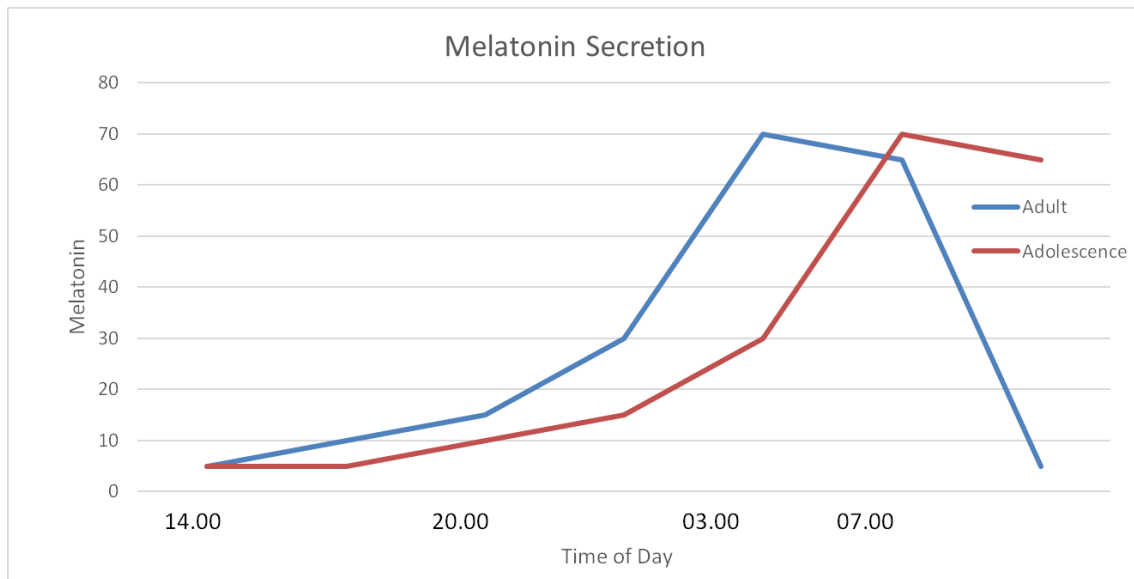

Figure 1: Daily Melatonin Secretion Levels. Source: Siobhan O'Neill

can cause excessive daytime sleepiness and the need to catch up on sleep debt at the weekends.

Stress during adolescence

As sleep patterns alter during adolescence, similarly experiences of stress can change during this developmental period. Adolescence is marked by novel experiences and biological changes in the body and these can increase the chances of stressful experiences occurring.

During the stress response a hormone called cortisol is secreted, this hormone readies the body for action by increasing heart rate and supplying large muscles with energy. This is an adaptive response to stress, however prolonged or chronic secretion of cortisol can have many adverse effects on the body and health including increasing the risk for hypertension, obesity and memory problems. Previously it was thought that the effects of stress-mediated cortisol did not emerge until adulthood, but there is accumulating evidence that these effects are present in adolescence.

Sleep, stress, and health

Poor sleep can have many deleterious effects on health and wellbeing. While asleep, our bodies maintain our physical health and support brain functioning, and during childhood and adolescence sleep also supports development. Insufficient sleep and poor quality sleep can have a large impact on your physical health, and has been linked to chronic illnesses such as: diabetes, cardiovascular disease, kidney disease, and obesity.

Table 1: Technology Use at Night, Sleep in America Poll 2011

Technology Type	13-18 Year Olds	19-29 Year Olds
Phones	72%	67%
Computers/Laptops	60%	60%
Music Device	64%	43%
Television	54%	59%
Video Games	23%	18%

1. Poor sleep can also have an impact on cognitive function and performance. A lack of sufficient sleep can cause short-term memory problems, work performance issues, poor academic achievement, mood swings, behavioural problems and daytime sleepiness.
2. Similarly stress has been linked to many poor health outcomes including poor sleep, cardiovascular disease, and depression. Evidence from studies of adults suggests a strong role of early life stress on the risk of obesity. Adolescents with obesity have a higher likelihood of contracting these serious life-threatening in adulthood and this may be the result of too much stress or too little sleep, or more likely the interaction of both of these factors.

Sleep and technology

Technology use has become a normal part of everyday life for many, especially young people. Figures from the Sleep in America Poll (2011) indicate that the 13-18 year old age group use far more technology than any other, and a significant percentage of people aged 13-29 use multiple devices in bed during the hour before falling asleep (Table 1). This is very problematic in terms of preparing the body for sufficient sleep quality and duration. Adolescents are delaying their sleep onset by engaging with devices that stimulate the minds and arouse their emotions. Not only that, these devices are also affecting their natural melatonin secretion pattern. Blue light is emitted from devices such as phones, laptops and tablets, and this blue light has been found to delay melatonin secretion and therefore sleep onset by up to two hours when used before bedtime or whilst in bed in an adult population.

My research

My first study, The CLASS Study (Changing Lives: Adolescent Stress and Sleep), is a longitudinal project investigating the effects of stress, sleep, and technology use on health in adolescents in Ireland. In particular the effects of poor sleep and prolonged, chronic

stress on obesity will be examined. The central research questions for this study are as follows:

Does technology use before bed delay sleep onset in adolescence?

Does stress and higher levels of cortisol contribute to the onset of poor health outcomes, including obesity, in adolescence?

Does poor sleep contribute to the onset of obesity during adolescence?

Is there an interaction effect between sleep, technology use, and stress on obesity during adolescence?

Participants take part in the study for a 12 month period, with data collection occurring three times in total at 6 month intervals (0, 6 and 12 months). The participants are aged between 12 and 25, and include both second and third level students.

My study incorporates both standardised questionnaires on sleep, stress and health, as well as daily diaries of stressful experiences and food intake. Participants are also asked a series of questions about their use of technology, both during the hours before bed and their levels of engagement with technology on a daily and weekly basis. Participants also provide saliva and blood samples to measure their stress hormone, cortisol, and a number of other hormones linked to chronic stress.

At each of the three sessions participants are seen in their school where they fill in the survey and provide height and weight measurements, and then for four days following that session (Saturday-Tuesday) they fill in the daily diaries and provide a number of saliva samples to capture their individual daily cortisol patterns. This research is currently on-going.

My second study is an online survey examining the factors that contribute to poor sleep. As mentioned above technology use has been found to delay sleep onset due to the suppression of melatonin by blue-light emissions from devices. However, very little research has examined the effects of the emotional arousal caused by technology use and its effects on sleep onset. Is delayed sleep onset caused purely by the biological effects of blue light, or does level of emotional arousal also play a part?

The main aim of this survey is to investigate the impact technology use, reading, and listening to music has on sleep onset and also to investigate the impact that the emotional arousal of these activities has on sleep onset. The secondary aim of the study is to investigate how pets, children and environmental noise impact on sleep quality and duration, in order to more fully understand the complexities of contributing factors to poor sleep. This study will recruit participants from around the world and will investigate cross-cultural differences in sleep quality.

Research impact

It is clear that poor sleep and stress can have a deleterious effect on health. The CLASS Study is the first study to investigate the combined effects of poor sleep and stress on obesity in an Irish adolescent population. There is a strong body of research investigating the effects of stress on an adult population but there is significantly less investigating stress in adolescence. This study has the potential to impact on public best practice policy for sleep and health guidelines in relation to obesity. This research could also inform interventions that would potentially lessen the likelihood of adolescent and long-term obesity in an Irish population.

The online study may provide a more cohesive understanding about the factors which contribute to delayed sleep onset, poor sleep quality, and poor sleep duration. It will also determine the impact of emotional arousal of bedtime activities on sleep hygiene. It will also potentially add to the best practice literature on good sleep hygiene. The online survey may also provide information for the development of a new standardised questionnaire on sleep hygiene.

Future research needs to examine the effects and interactions of melatonin secretion and emotional arousal on sleep onset in adolescence in order to fully investigate the impact of technology use on sleep. As obesity during adolescence has been linked to long-term obesity and chronic illness, further investigation is needed on the causes of obesity at this time and during childhood in an Irish population.

I would like to thank my supervisor Dr. Samantha Dockray, for her support and advice. I would also like to thank the participants who have taken part in The CLASS Study. Funding for this work was provided by the Irish Research Council.

The European Public Prosecutor's Office: An institution built on sand?

Brian O'Reilly

Department of Law, UCC

“And the rain descended, and the floods came, and the winds blew, and beat upon that house; and it fell: and great was the fall of it.” (Matthew 7:27 KJV)

Introduction

The European Union has traditionally had a limited role in the area of criminal justice enforcement. Many other areas of EU law involve detailed legislation and direct involvement, but in relation to criminal law the EU has thus far been limited to a coordinating and harmonising role. There are, for example, certain minimum standards set on the national definitions of some serious criminal offences, and an attempt has been made to harmonise the types and level of sanctions applicable to certain offences, but when it comes to actually prosecuting these crimes the Member States still reign supreme. In Ireland, the job of prosecuting criminal offences in the Courts falls ultimately on the Director of Public Prosecutions (DPP). This could be set to change, however, as a regulation is currently (slowly) working its way through the EU legislature that would set up a European Public Prosecutor's Office (EPPO), which could effectively operate as a sort of DPP for the entire European Union. My research seeks to critically analyse this EPPO regulation in order to evaluate its potential impact on the Irish criminal justice system, with a view to making a recommendation as to whether or not Ireland should accede to this Office in the future.

The Lisbon Treaty and draft regulation

The potential for the establishment of a European Public Prosecutor's Office was introduced into the text of the Treaty on the Functioning of the European Union (TFEU) by the Treaty of Lisbon. Article 86(2) TFEU states:

The European Public Prosecutor's Office shall be responsible for investigating, prosecuting and bringing to judgment [...] the perpetrators of, and accomplices in, offences against the Union's financial interests [...]. It shall exercise the functions of prosecutor in the competent courts of the Member States in relation to such offences.

Following the coming into effect of the new Treaties, the European Commission published a recommendation for a Council Regulation (a draft Bill) establishing the EPPO in 2013. This recommendation was adopted by the European Parliament, and is currently undergoing (extensive) revisions by the relevant Member State government Ministers in the

Council of the European Union. The regulation, as drafted by the Commission, sets up a unique framework within which the EPPO will operate. Although the EPPO will be a supra-national Office, in practice it will be inserted into the various national criminal justice systems. This is an important innovation on the part of the Commission since, in the hierarchy of laws, even the lowest EU law ranks above the highest national law, as established by the European Court of Justice in the 1964 *Costa* case. Without this unique proposed setup, the procedural rules surrounding the EPPO could have been in conflict with (and would have taken precedence over) national constitutional standards, which for many would simply be politically untenable (particularly in a country like Ireland, where the Constitution is so directly linked to the concept of popular sovereignty, since *Bunreacht na hÉireann* may only be amended via national referendum). Although the draft law sets out that the EPPO will be subject to almost all national law, however, rules of evidence will still be governed at EU-level in order to ensure that evidence gathered legally in one Member State would be admissible in the Courts of another. This leaves open the possibility of constitutional tensions in relation to the admissibility of evidence, and will be an area of particular focus in my research. By way of example, one could imagine an Irish defendant being prosecuted in an Irish Court, with evidence being adduced by the European Prosecutor that was collected by the national authorities of some other Member State from the defendant's private residence in that other Member State. Potentially, even if the evidence had been gathered legally under the national laws of that country, it may not have been gathered in a manner consistent with the Irish rules (which, in the case of evidence gathered from a person's residence, stem from the Constitution). If that same evidence had been gathered from the defendant's home in Ireland, then the relevant Irish constitutional rules and jurisprudence would be applied to it before determining whether or not it was admissible at trial. Under Article 30(1) of the draft EPPO regulation, the evidence gathered in our example above would be deemed admissible "where the court considers that its admission would not adversely affect the fairness of the procedure or the rights of defence as enshrined in Articles 47 and 48 of the Charter of Fundamental Rights of the European Union," and therefore any specifically Irish evidentiary requirements would not need to be met in relation to that particular piece of evidence. Thus a different, and possibly lower, level of scrutiny would be applied to evidence gathered in other Member States, which could lead to an adverse knock-on effect for an Irish defendant at trial.

The EPPO has the potential to constitute a leap forward in terms of a developing criminal justice sphere within the EU. It would be the first EU body with prosecutorial (as opposed to simply coordinating or facilitating) powers, and would allow the EU to directly defend its own financial interests. The proposal is not, however, without its detractors, and there still exists the very real possibility that some Member States' reservations, and a fear of creeping European federalism, could diminish the role of the EPPO to the point of redundancy. Some of the amendments put forward by Member States in the Council of the EU could be seen as chipping away at the very foundations of the Office before it is even established.

National reservations and 'yellow cards'

There exists in the EU's legislative process a little-known procedure known colloquially as the subsidiarity 'yellow card'. This procedure allows national parliaments to have a say on draft EU legislation, and to require a response from the Commission if they feel such legislation is in breach of the principle of subsidiarity, a principle set out in Article 5(3) of the Treaty on European Union in the following terms: "[T]he Union shall act only if and in so far as the objectives of the proposed action cannot be sufficiently achieved by the Member States [...]". Each national parliament has two votes (one per chamber in a bicameral system, and two to the single chamber in any unicameral system), and a 'yellow card' is triggered in this particular area of EU law if chambers representing one quarter of the votes (14 out of 56) issue a reasoned opinion that the draft law breaches the principle of subsidiarity. In the case of the EPPO regulation, 14 chambers (representing 18 votes) issued such an opinion, forcing the Commission to issue a response, explaining how it would take these concerns into account. The reservations expressed by national parliaments ranged from fears of the EU encroaching on national sovereignty, to claims that the EPPO would provide no added-value, to assertions that 'our national prosecutors are doing just fine on their own thank-you-very-much'.

As the 'yellow card' threshold was met, the Commission was legally required to review the draft, before deciding whether to maintain, amend, or withdraw it, with reasons given for this decision. Rather expectedly, it decided to maintain the draft as it was. Rather disappointingly (well, depending on who you are, I suppose) it justified this decision in a mere 13 pages. To put that into some context, the reasoned opinion of the UK's House of Commons (just one chamber out of 14 issuing such opinions) stacks in at a hefty 62 pages.

Though every Member State is currently involved in the drafting and redrafting of the EPPO regulation, many have already expressed their intention not to take part in the Office. Ireland is one such state. The EPPO will thus initially be set up under the enhanced cooperation procedure, and will not have EU-wide jurisdiction, but those Member States that are less comfortable with the concept of an EPPO, and which will *not* be under its jurisdiction, still have the opportunity at this stage to weaken its structures. The fact that the draft law is currently undergoing extensive amendments in the Council of the EU is perhaps a reflection of, or indeed a reaction to, the Commission's rather cavalier response to genuine national concerns. This reaction, and the subsequent sweeping amendments to the proposal, risks the creation of a European Public Prosecutor who will be forced to live in a house built by the Member States on a foundation of sand.

My research

My research critically analyses the (evolving) text of the Council Regulation establishing the EPPO in order to evaluate its potential impact on the Irish criminal justice system, considering both the position of Ireland as a non-participating Member State (including its interaction with the Office as a third party), and its potential future involvement, with a view to providing a recommendation as to whether the State should accede to the Office. It questions whether the decision to initially remain outside the Office was justified in light of Ireland's common law traditions, and will seek to clarify Ireland's genuine reasoning behind not taking part in the EPPO. Irish engagement with the proposals thus far appears to have been cursory at best, the reasoned opinion of the Joint Committee on Justice, Defence and Equality, for example, consisting of a grand total of two pages, despite serving as the opinion for both the Dáil and the Seanad. It is hoped that this research might help inform a more nuanced and considered approach to the EPPO, and prompt a genuine debate on Ireland's potential accession following its establishment.

As the EPPO regulation proposes such a potential leap forward towards a proto-federal EU criminal justice system, the political concerns of the Member States cannot be ignored in a legal analysis of its provisions. Some of the key issues I aim to discuss include how investigations are to be conducted in Member States under the EPPO's authority, how its actions may be appealed via judicial review, and how national rules of evidence could be affected. This latter issue is one of the most likely to have a direct impact on the rights of citizens accused of crimes, since, as mentioned above, prosecutions undertaken by the European Public Prosecutor could potentially be held to less stringent evidential standards than those undertaken by the Director of Public Prosecutions.

Even before a finalised text is arrived at, it is important to analyse the differing positions between the Commission and the Council; the differences between an idealised potential and an eventual reality. The EPPO has the potential to usher in a genuine European criminal justice area. At the same time, it is at serious risk of having its foundations swept out from under it by the ebb and flow of the more wary Member States.

Brian O'Reilly is a first year PhD student in the Department of Law, under the supervision of Dr. Fiona Donson. His research is funded by the UCC Faculty of Law PhD Scholarship.

Silence please!

Jane Maeve O' Sullivan

School of Applied Social Studies, UCC

Introduction

“Shut up and eat your dinner!” Given that I grew up in an era in which it was considered that children should be seen and not heard the preceding demands were not at all unusual and regularly demanded at our family dinner table. In the not-so-distant past children were viewed as empty vessels in need of being filled with knowledge and “manners”. Their role was not to question but to accept the guidance, wisdom and discipline of knowing adults. Our view of childhood, however, has evolved. Today we recognise that children play an active role in their own lives and development. Instead of viewing children as *human becomings* we recognise them as *human beings*, as citizens, and like all citizens, children hold rights. In 1992 Ireland ratified the United Nations Convention on the Rights of the Child (CRC). Amongst other rights, this treaty affords children the right to be heard. Specifically, Article 12 of the convention states that children have the right to voice an opinion in any matter that effects them and that their opinion must be considered in any decisions concerning them, in accordance with their age and maturity. Research has found that as a society we are making progress, children’s voices are increasingly being included within the community and the family context. Within the school context, however, this right is proving to be problematic. This research will explore why.

Participation

The term participation has become shorthand for the rights contained within Article 12 of the CRC, that is, children’s right to be heard and to contribute to decisions affecting them. An extremely wide range of activities and projects are clustered under the umbrella of participation, from everyday decisions within daily family life to public protests that challenge adult authority. Broadly speaking participation can be divided into two categories: formal and informal. Formal participatory mechanisms include youth parliaments, school councils and children’s participatory research while informal participation refers to children being heard and contributing to decisions within their everyday lives. In the last thirty years or so children’s participation has received considerable academic and policy focus as the pressure mounts to recognise children as rights holders. Through formal participatory mechanisms, children as a collective are beginning to have a voice within society and within policy development, while individually children are now afforded a voice in judicial or administrative proceedings. Notwithstanding these benefits, formal

participation has been criticized for its failure to facilitate *all* children's rights to be heard within their everyday lives. The numbers of children involved in formal participation is a very small percentage of the whole. Furthermore, it is often articulate middle-class children who are involved in these mechanisms which is unfortunate given that marginalized, disadvantaged or vulnerable children, i.e. the very children most in need of being heard, are the ones least likely to be involved in formal participation.

While the focus has, to date, been on the promotion of formal rather than informal participation, in recent years there has been a growing appreciation regarding the need to create meaningful participation for *all* children within the everyday spaces they occupy. In other words, to make sure all children can enjoy their right to be heard within their everyday lives. It has been argued that a greater emphasis should be put on creating informal participatory spaces within children's everyday lives rather than the previous emphasis on formal mechanisms/spaces such as school councils and youth parliaments and that recognition must be given to children's spontaneous participation which occurs within their everyday mundane lives and interactions. We must work to develop a culture in which we listen to all children and give genuine consideration to their perspectives. What children think and feel about any issue that impacts on them must matter. Given, therefore, that the vast majority of children spend up to half of their waking lives in school it is vital that we work to support children's informal participation within the school context.



Figure 1: Image used courtesy of Wissam Abdel Samad

In order to promote and support the participation of all children within their everyday lives it has been argued that we need to re-frame research on children's participation by re-positioning adult/child relations and the spaces in which they occur as the central focus. In other words instead of focusing on the merits or success of particular participatory mechanisms and projects, as research on participation has traditionally done, we need to look to how the relationships between an adult and a child impacts on the likelihood of the child being heard, while also examining the impact of the context in which that relation-

ship occurs on the level of participation the child is afforded. This approach is particularly appropriate for the exploration of children's right to be heard given that facilitating this right requires a negotiation between child and adult. This negotiation is influenced by the nature of the relationship between the child and the adult as well as the context in which this negotiation takes place (e.g. school, home etc.). Adults, therefore, play a vital role in supporting children to avail of their right to be heard/participate, with teachers being key to the implementation of this right within a school context. The relationship between teachers and their pupils is determined by many factors including the numerous constraints and structures (such as pupil/teacher ratios and curriculum demands) that teachers must work within, the teacher's perspective on what is appropriate for children, their own role as a teacher and the culture within the school.

Research Question and Methods

The aim of my research is to identify the factors that either support or prevent children from enjoying their right to be heard within a primary school context. To achieve this I am focusing on the relationships between teachers and pupils and the spaces in which they occur. I am in the process of visiting up to five primary schools. In each school I begin by interviewing the principal following which I spend up to a week observing in two different classrooms. I then interview the teacher from both classrooms and finally conduct two focus groups with small groups of children from both classes. This approach allows me to observe the relationship/interactions between students and teachers while also giving me the opportunity to glean both children's and adults' perspectives regarding the issue of being heard. Once all the data has been gathered it will be critically analysed manually and also using computer assisted qualitative data analysis in order to identify both the factors that serve as barriers and also those that enable the realisation of children's right to be heard within a school setting.

A Participatory Rights Based Approach

One of the exciting aspects to this research is that I will not be doing it alone, I will be advised throughout the process by a group of experts - ten children aged between five and eleven. Given that a fundamental premise of this research is that children have the right to voice their opinion in any matter that concerns them, as this research concerns children it is imperative that I 'walk the walk' and not just 'talk the talk' by honouring and facilitating this right within the research. While children's ability to participate in research has gained widespread recognition, children's rights discourse moves beyond the recognition of children's ability to participate in research by actively promoting their right to participate. My advisory group is contributing to how I conduct the research, the analysis of the data gathered and the dissemination of the research findings. There are many challenges to conducting participatory research with children, not least of which, is

the need to use methods that are child centred and also navigating the level of decision-making power children possess as research participants. Another issue is the need to develop children's knowledge and understanding of the issue being researched in order for them to have the capacity to engage with the relevant research issues. There is a scarcity of research conducted with children in this manner, perhaps on account of limitations in the extent to which young children can contribute to adult-led research. Within a rights based approach however, the onus is on researchers to do so nonetheless. This research will, therefore, not only contribute to our knowledge regarding the barriers and enablers of children's right to be heard in a school context, but will also contribute to filling the gap in to our knowledge regarding best practice in conducting adult-led participatory research with younger children.

Conclusion

Promoting children's voices within the classroom has been found to benefit both teaching and learning so it's a "win win" for pupils *and* teachers. Doing so, however, is not just good practice, it's an obligation. Both the United Nations Convention on the Rights of the Child as well as the Government of Ireland's National Policy Framework for Children and Young People 2014-2020 require that any adults who work with children do so in a manner that facilitates children's right to be heard. The difficulty is, knowing how to do this in a classroom of up to thirty children while at the same time ensuring that each child is provided with an education that meets strict predetermined learning outcomes. As a former preschool teacher, I am fully aware of how tremendous a challenge this actually is. This research will provide valuable guidance that will support teachers and educators in knowing how to develop a culture within their schools and a classroom that respects and facilitates children's voices. By providing evidence based recommendations and suggestions for teachers to draw on, this study will help to bridge the existing gap between policy and practice.

The author would like to thank her supervisors Dr. Deirdre Horgan and Dr. Jacqui O' Riordan for their on-going support and encouragement. This research is funded by the Irish Research Council.

The Secret Lives of Postnatally Depressed Dads

Lloyd Frank Philpott

School of Nursing and Midwifery, UCC

Introduction

Close your eyes and take a moment to think about postnatal depression (PND). What comes into your mind? What images present themselves?

Historically, PND has typically been associated with women. It has also been perceived as a product of biological causes. Consequently, most of the research to date has focused on mothers. However, researchers now conceptualise that PND is also the product of psychosocial causes such as sleep disturbance, relationship conflict and financial strain. It can therefore be presumed that such factors would also impact on the mental health of fathers or male partners in the postnatal period. The study of Paternal Postnatal Depression (PPND) is still in its infancy. However, an understanding of the problem has advanced considerably over the last ten years.

Men, Fatherhood and PPND

The transition and adaptation to fatherhood is considered one of the most acute transformations experienced during a man's life. The experience is influenced by personal, infant and environmental factors. Aside from the many joys, the postnatal period is marked by significant change and the absence of routine. Fathers experience many of the same changes and stresses that mothers do. While some fathers anticipate that they may find it difficult to adapt to parenthood, many fathers are not fully aware of the impact a baby will have on their lives.

Unprecedented social change in the previous four decades has seen a great shift in the role of fathers. This has resulted in the expectation that men play an equal and direct role in caring for their children. However, a great number of fathers have not had a role model from whom to learn appropriate fathering skills, having grown up in a time when men were either uninvolved or minimally involved in child-rearing. This has resulted in some men feeling inadequate and ill equipped as they begin their journey into fatherhood. This can subsequently cause PPND.

During the postnatal period (the period beginning immediately after the birth of a child and extending for six weeks) both mothers and fathers are at increased risk of depression.

PND is a non-psychotic depressive disorder that occurs after the birth of a child and has traditionally been considered a disorder of women. Maternal PND (MPND) is a well-known condition that has been extensively researched and described in literature. In contrast, PPND is not widely acknowledged and not well researched. In general the mental health of fathers in the postnatal period is often not considered and this has resulted in men being under screened, underdiagnosed and undertreated for PPND and other postnatal mental health problems.

What we know about PPND

Prevalence: Estimates of the prevalence of PPND within the first year after the birth of a child vary widely ranging from 1.2% to 27.5%. It is suggested that the wide statistical variation of estimates is related to the fact that different measurement tools are employed across studies. In addition, those studies that use the same measurement tools use different cut-off scores. An analysis of 43 PPND studies reported an average prevalence of 10.4%. Thus far, only one Irish study on PPND has been undertaken. 100 fathers from the south of Ireland were screened for PPND in 2014 with the researchers finding a prevalence of 12%.

Risk factors for PPND: Maternal depression has been identified as the most important predictor for PPND. Depression in one partner is significantly correlated with depression in the other. Fathers are more likely to be depressed if their partner is experiencing MPND. Having a history of clinical psychiatric treatment is another risk factor that is strongly linked to the development of PPND. It is suggested that this may be due to predisposing genetic factors and/or enduring environmental factors, with the perinatal period acting as a stressful life event which triggers remission.

The lack of choice and preparation inherent in an unplanned pregnancy also increases the risk of PPND. Other factors associated with a higher prevalence of PPND include unemployment, an unstable source of income, lower income levels, living in rented accommodation, low-income housing and overcrowded housing. Many of these demographic and socio-economic variables are associated and may act as indices of social deprivation.

Alternatively, social support networks act as a buffer and reduce the risk of PPND. It has been reported that fathers with higher levels of social support networks have a lower prevalence of PPND. Figure 1 outlined below highlights the risk factors for PPND.

Manifestation of PPND: PND in women is characterised by sad mood, apathy, anxiety, sleep disturbance, reduced self-esteem and difficulty coping with day-to-day tasks and mood. PND in men manifests itself differently and includes such symptoms as hostility, conflict and anger. In addition, men tend to withdraw or engage in escape activities such as overwork, sports, sex, gambling and alcohol abuse.

Impact of PPND: The impact of MPND on infants and children is well documented. Recently, research has been conducted concerning the impact of PPND on infant and child development and well-being. Findings indicate a higher risk for increased family stress, lack of bonding, increased incidences of physical punishment and later child psychopathology such as emotional issues, conduct disorder and hyperactivity. Furthermore, the risk for negative parenting outcomes increases when both parents are depressed. Fathers play an important role in buffering their children from the effects of MPND. However, this buffer is lost when the father also has PND. When both parents are depressed infants are less likely to be put to sleep on their backs which increases the risk of sudden infant death (SIDS) or to be breastfed. Fathers are also less likely to play and interact with their infant if they are depressed.

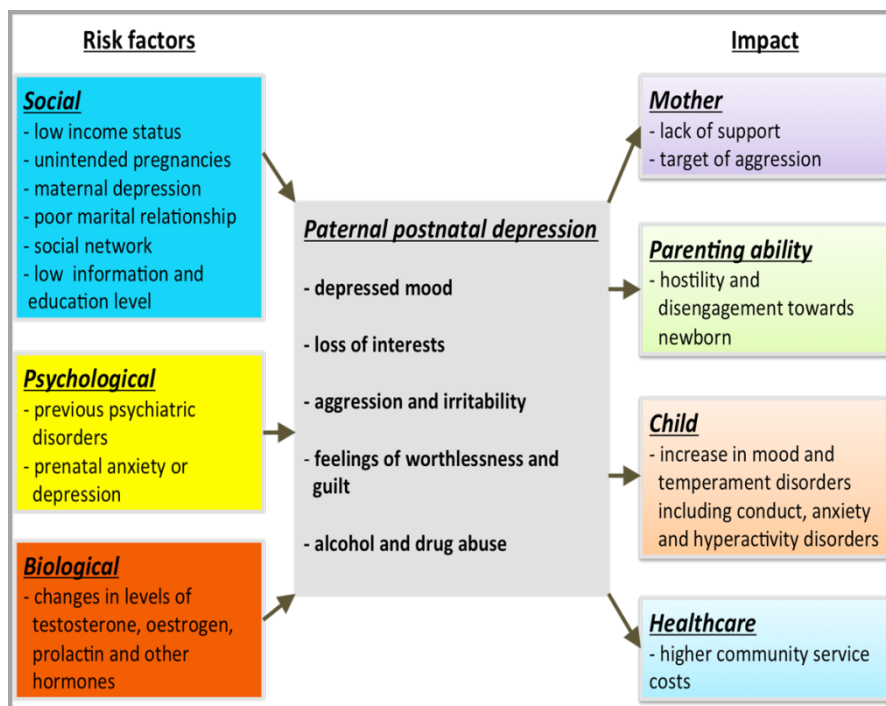

Figure 1: Risk factors, manifestations and impact of paternal postnatal depression. Source: Author

What we don't know about PPND

Research on PPND is still in its infancy so there are many aspects which have not yet been studied. Thus far the majority of PPND research has been undertaken in the US and Australia with white, middle class and married fathers. There is a paucity of knowledge in relation to PPND among fathers in non-traditional family settings i.e. stay at home fathers, non-biological fathers and single fathers and among fathers from minority ethnic groups and from different socioeconomic backgrounds. There is a need for research to be undertaken with fathers in these groups in order to identify their specific and unique risk factors. There is also a need for research to be carried out on the lived experiences of

fathers with PPND.

My Research Plan

As part of my research, I plan to interview fathers who have been diagnosed with PPND. My research will give an insight into the lives of fathers who have experienced PPND. I will highlight each fathers experience before, during and after the birth of their infant, their self-recognition of symptoms of PPND, their help seeking behaviour, their treatment experiences and what they consider to be the ideal treatment for PPND. It is envisaged that the findings and subsequent reporting of the study will increase awareness of the problem and help fathers, their families and healthcare professionals better understand and recognise PPND.

Conclusion

PND has typically been associated with women. Consequently, most of the research to date has focused on mothers. However, research carried out over the last decade has revealed that PND can also impact on the mental health of fathers. Estimates of the prevalence of PPND within the first year postpartum are approximately 10%. Several risk factors have been identified and these include living in rented accommodation, poor economic circumstances, not being married, having a history of depression and lack of social support. Despite an increase in research related to PPND over the last decade, the problem remains hidden and it is presently underscreened, underdiagnosed and undertreated.

Now close your eyes and take a moment to think about postnatal depression. What comes into your mind? What images present themselves?

I would like to thank my supervisors Dr. Patricia Leahy-Warren and Dr. Helen Mulcahy for their continued support.

Shave of the brave: Self-concept in chemotherapy-induced hair loss

Sinead Power

School of Nursing and Midwifery, UCC

“A woman who cuts her hair is about to change her life”... Coco Chanel

Background

Historically, hair has played an important role in society, symbolising masculinity and virility in males and youthfulness and beauty in females. Furthermore, hair has traditionally been indicative of social, religious and professional status. For example, Christian priests and monks once shaved the crowns of their head to symbolise a lack of vanity and their vow of chastity. In ancient Egypt, the Pharaoh always wore a wig to denote his status. For women, hair is an important indicator of femininity and attractiveness in society. The term “crowning glory” was used in the Bible to denote a woman’s hair: “but for a woman, if her hair is abundant, it is a glory to her, for her hair is given to her for a covering” (Corinthians 11: 15). Figures from the United States indicate that the average woman spends approximately \$50,000 on her hair over her lifetime, thus illustrating the importance of hair in society. Thus, given the significance of hair in society, it is clear that the loss of hair, particularly within the context of cancer treatment is a source of distress for individuals.

In recent years, advances in the treatment of cancer mean that many individuals are living longer with a cancer diagnosis. However, these advances in treatment mean that more patients experience the many side effects associated with cancer and its treatment. These include nausea and vomiting, fatigue, memory loss; neuropathic side effects such as pins and needles; and hair loss. While all of these side effects impact on the lives of individuals, hair loss resulting from chemotherapy is a side effect which causes significant disruption to patients’ daily lives. This is mainly due to the fact that hair plays an important role in one’s outward presentation and appearance. Consequently, the loss of one’s hair impacts on one’s physical, psychological and social well-being. Chemotherapy-induced hair loss affects individuals (male and female) with a variety of cancers including breast, testicular, lung, gynecological and hematological cancers. For example, hair loss resulting from chemotherapy occurs in 50% of patients with breast cancer. Research studies have illustrated that some individuals may refuse potentially curative treatment due to anxiety and concern relating to hair loss. There is a perception that chemotherapy-induced hair loss is mainly associated with the loss of head hair. Patients may not always be aware that hair

loss affects all areas of the body. This includes the loss of eyelashes, eyebrows, nasal hair, pubic hair, chest hair and leg hair. Chemotherapy-induced hair loss is temporary. For many individuals, hair generally begins to return between 6-9 months post the commencement of chemotherapy. However, for a number of patients, “new hair” is often very different to how it looked prior to hair loss. For example, hair that was once long and blonde may return grey and short. This change may have a lasting impact on an individual’s self-concept, impacting negatively on body image, perceptions of how one is viewed by others, social functioning, psychological well-being and self-worth. Due to the temporary nature of chemotherapy-induced hair loss, there is evidence that some healthcare professionals tend to under-estimate the impact of hair loss on patients. However, patients are clearly adversely affected by this side effect of cancer.

Aim of the study

The overall aim of the study was to explore and examine self-concept in patients with primary cancer who had experienced chemotherapy-induced hair loss. Primary cancer is defined as cancer which has not spread to other parts of the body. The study was conducted in two phases. In the first phase of the study, participants were interviewed regarding their experience of chemotherapy-induced hair loss. Phase 2 involved the completion of an online questionnaire. For the purposes of this paper, I will present the findings of phase 1, in which participants were interviewed regarding their experiences of hair loss.

Methods

Permission to conduct the study was granted by the local ethics committee. Males and females were invited to take part. Flyers and posters advertising the study were distributed in a local cancer support house and a centre of excellence in cancer care. Thirteen females who had experienced chemotherapy-induced hair loss agreed to take part in the study. No males expressed an interest in taking part in the study. These participants were interviewed individually, using semi-structured interviews and were asked to speak about their experience of hair loss. These interviews were transcribed word for word by the researcher. The transcripts of the interviews were analysed in detail. Six categories emerged following analysis of the data.

Findings

Six categories emerged following the analysis of the data. These included: Preparing for hair loss; hair loss as a symbol of cancer; camouflaging hair loss; impact of hair loss on aspects of the self; physical discomfort associated with hair loss and the re-growth of hair.

All participants spoke of how important it is to be adequately prepared and informed prior to the onset of hair loss. Being adequately prepared was seen as a means of “maintaining

control”, as for many patients cancer is typically associated with a loss of control. Participants were adamant that they did not want to wait until hair began to fall out, thus hair was cut short or shaved prior to hair loss.

For all participants, hair loss was perceived as a “physical label” which identified them to others as cancer patients. Some participants did not feel that they had cancer until they looked at themselves in the mirror. They described seeing themselves without hair and suddenly realising the gravity of their diagnosis. All of the women interviewed spoke of the difficulties they experienced while trying to keep their cancer diagnosis private from members of the public. They felt uncomfortable when members of the public began speaking to them about their cancer, particularly when they had not disclosed it.

All participants considered camouflaging their hair loss important. Camouflaging was seen as “essential” and “necessary” in allowing the women to continue with their day-to-day activities and also to “hide” their cancer diagnosis from others. The selection of the wig was identified as a key time, but a “lonely” time for participants. While the wig was considered to be a necessity, all of the women voiced their distaste for the wig, stating that they “hated” it. Wigs were also described as “hot” “tight” and “uncomfortable”.

It is clear that hair loss impacted on all aspects of participants’ self-concept. All of the women interviewed spoke about how their hair loss adversely affected their physical self-concept (body image), emotional self-concept (psychological well-being) and social self-concept (how one feels he or she is perceived by others). Participants spoke of how hair loss dramatically changed their appearance. This alteration in appearance impacted on how they felt they were viewed by others. Additionally, it is clear that hair loss caused distress to participants, thus affecting their emotional well-being.

With regard to physical self-concept (body image), one woman poignantly described herself without hair as “a medical experiment gone wrong”. Furthermore, responses from other participants suggest that one’s body image continues to be affected, even following the re-growth of hair. The lasting effect of hair loss on body image is vividly described by participant 12, who was one year post hair loss at the time of her interview.

“I’m still trying to find my new identity. . . I know the old me is gone. . . now I need to settle with the new me. . . but I’m not sure if I’m ready for that yet. . . . you know when I go for a shower. . . that’s not me that I see, I have to get used to, you know get used to the new me and how I look now. . . .” (Participant 12).

Hair loss also adversely impacted on the social self-concept of individuals. Participants were concerned about how others viewed them during the course of their hair loss and felt that they had a social obligation to prevent causing distress to others. The women were unsure of how to react when others complimented them on their “new hairstyle” (wig). They were also fearful of causing upset to others on seeing them wearing their bandana or on seeing their ‘bald head’.

All of the women interviewed spoke of how their hair loss had affected their emotional self-concept. It is clear that hair loss caused upset and distress for participants and their close family members. Participants spoke of how they were “baffled” at how their hair loss had upset them, describing it as “horrific”, “desperate” and “awful”. Some of the participants were mothers of young children. The response below from participant 10, poignantly describes the emotional impact of hair loss on children.

“[...] and then one morning you wake up and your hair... your hair is falling out [...] you know, on the pillow, in the shower [...] IT WAS ON THE KIDS [...] I hugged one of my daughters and it was all over her [...] a big clump on her shoulder [...] I mean, I took it off her as quickly as I saw it but, [...] she saw it [...] she was very brave in front of me [...] but later on that night [...] she was crying in bed [...] (Participant 10).

This young mother had experienced chemotherapy-induced hair loss resulting from breast cancer 12 months prior to her interview. This poignant statement illustrates the impact that chemotherapy-induced hair loss had on this participant and her daughter.

For 12 of the participants, hair had started to return or had fully returned. One participant was 2 months post-hair loss, thus she had complete hair loss at the time of her interview. All participants were concerned about the following issues: the length of time to re-growth (one participant referred to “being in limbo” in relation to the re-growth of her hair); some participants were worried that hair may not come back at all; apprehension regarding the re-growth of hair i.e. what would it look like; the difference in quality, texture and colour of “new hair” and the readjustment associated with the re-growth of hair.

It was interesting to note that some participants had adjusted to how they looked with the wig and were reluctant to stop wearing it, once hair had started to return. The women spoke about how “comfortable” they had become wearing the wig and the apprehension they felt about revealing their “new hair” (which now looked very different to how it had looked previously).

Conclusion and recommendations

The findings of this study are significant and have important implications for cancer care. All participants spoke vividly and emotionally about their experiences of hair loss. The key categories included: preparing for hair loss; hair loss as a symbol of cancer; camouflaging hair loss; impact of hair loss on aspects of the self; physical discomfort associated with hair loss and the re-growth of hair. It is essential that healthcare professionals assist patients in their preparation for hair loss by providing them with information on what to expect and on methods to camouflage hair loss. The emotional impact of hair loss on patients and on close family members cannot be ignored and patients need to be educated on how to speak to young children about hair loss. Furthermore the physical effects of hair loss need to be incorporated into patient education material. Patients also need to

know what to expect in relation to the re-growth of hair. Particular information needs to be given on when hair re-growth will occur and also information on the colour and texture of “new hair”. Programmes such as the Look Good Feel Better Programme® should be made readily available to patients in an effort to enhance their physical, emotional and social self-concept at all stages of their hair loss. This may in turn improve how individuals deal with their hair loss. The researcher acknowledges that all participants were females. Through targeting organisations which deal specifically with males with cancer, the researcher hopes that the gender imbalance seen in phase 1 will be addressed.

illuminating the future with LEDs

Silvino Jose Antuña Presa

School of Electrical and Electronic Engineering and Tyndall National Institute,
UCC

Knowledge once gained casts a light beyond its own immediate boundaries. (John Tyndall)

Introduction

Light-emitting diodes also known as LEDs are all around us: they are used in TVs, computers, mobile phones, street lighting and even in our homes in the form of new energy saving and long lifespan lamps.

Now you might be wondering: “why all the fuss? Is this another ‘new thing’ that is going to disappear in a couple of years or is this something that is going to stay?” Well, to the truth, LEDs have been around for some time: they were initially used as small indicator lamps and for small displays; in fact, almost any appliance you may have at home will have a small LED lamp to tell you whether it is on or off.

Things started to change when the first blue LED was demonstrated in 1994. Before this achievement the only available colours for LEDs with decent efficiency were red and orange-red. This was good for indicators and small displays but not for general lighting applications because we cannot convert red light efficiently into white light. However, we can readily convert violet and blue light into white light using yellow and red phosphors. So once the blue LED became available, we could start to develop white LED sources and the possibility of replacing our old lamps by new more efficient ones became real.

Just a couple of years later first green LEDs appeared on the scene. Green light sources are very important for two main reasons: firstly, because tri-chromatic red-green-blue light is needed for full colour displays, such as a computer or TV screens. Secondly, because the human eye has greater response to green and yellow light. This characteristic of the eye allows us to observe green light sources as being brighter, even if they are not as powerful as light sources in other colours.

Let there be light: How light-emitting diodes work.

Traditional light sources

Traditional light sources use heat to generate light. For example, the common incandescent bulb uses electricity to heat a small filament-wire. When this filament is hot enough

it starts to emit visible light; the physical effect of getting light from a hot body is called incandescence, which is a special case of thermal radiation or in other words, emission of electromagnetic radiation from a hot surface.

As we all know from personal experience, if you touch an incandescent bulb after it has been on for a while, it is hot. That is because not all the electricity driven to the bulb is converted into light; in fact, the largest part of the electricity is converted into heat. This is not an optimal solution because we want to get as much light as possible from as little power as possible. In other words, what we want is high efficiency light sources which transform current into light and not into heat.

Fluorescent lamps are a more efficient alternative although with several drawbacks: There is still a significant portion of current being converted into heat, and the generated light is ultraviolet which can be harmful and requires conversion to white light using a phosphor coating inside the fluorescent bulb. However, the biggest problem is that fluorescent lamps contain mercury, which is highly toxic and harmful to the environment. So in general fluorescent lamps are a good solution and still widely used for example in office buildings. However; we still need to search for a better solution.

Semiconductor light sources

Luckily enough, there is another way of getting light without the heat by using semiconductor materials. A semiconductor is a special kind of material which only conducts electrical current under certain conditions but not others. This allows us to control very precisely the electrical current through the material and which is the foundation of modern electronics. In a pure semiconductor at room temperature we can find two kinds of particles able to move when applying a bias. The negatively charged particles are electrons and the positive ones are holes, and both are called carriers in general. In a pure semiconductor material we have the same number of electrons and holes but we can add different types of impurities to these pure semiconductors and change its properties, this is called semiconductor doping. If we dope a material to have more holes than electrons, we end up with a material known as a (positive) *p*-type semiconductor and conversely, if we end up with more electrons than holes we obtain a (negative) *n*-type semiconductor. Furthermore, we can join a *p*-type and an *n*-type semiconductor in what is called a *p-n* junction. This forms a device which on one side has a *p*-type layer with more holes than electrons, then a junction-layer which is depleted of any carriers and finally a *n*-type layer with more electrons than holes. This kind of device is called a diode and it is widely used in electronics.

Ok, we now know what a diode is; but how do we get light from a semiconductor? If we look inside the material, we find that electrons and holes in the semiconductor have different energy levels with electrons in the higher energy states, and holes in the lower ones. When an electron meets a hole they are attracted due to their opposite charges; they

can recombine, in which case both disappear, and the energy is released as light. This is the key to understanding why LEDs can be so efficient: In an ideal LED, all the electrical energy can be converted into light without emitting any heat.

So when a LED is connected to a power supply, electrons and holes from the n - and p -side both move towards the junction where they recombine. And because we select a material with a suitable separation between the energy levels, we get light emission in the colour that corresponds with the chosen energy gap.

Figure 1 gives an example of the efficiency of incandescent, fluorescent and LED lamps. Incandescent lamps and the more recent halogen lamps are widely used in our homes but they are clearly the ones with lower light outputs per Watt. As mentioned before, fluorescent lamps have a good efficiency, but they have problems related with harmful UV-emissions and toxicity. On the right hand side of the graph the recent progress on LEDs is shown: current LEDs now surpass even the best fluorescent lamps.

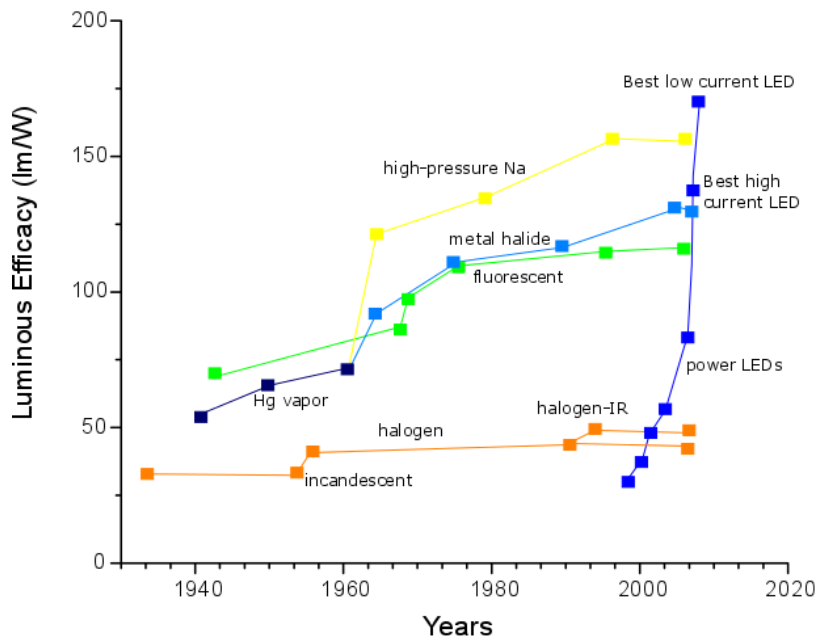

Figure 1: Conversion efficiencies of different light sources. Source: Author

A material worth a Nobel prize: Gallium nitride

The Nobel Prize for physics was awarded in 2014 to I. Akasaki, H. Amano and S. Nakamura “for the invention of efficient blue light-emitting diodes which has enabled bright and energy-saving white light sources”. As explained in the introduction, a blue light source is required to achieve white light by conversion of part of its light output with yellow and red phosphors or combining it with red and green light sources. These first LEDs were fabricated using a material called gallium nitride (GaN). GaN is a semiconductor capable of emitting light in violet and blue colours, but what is interesting is the fact that if we

add small percentages of the chemical element indium to the GaN, we can get lower energy colours such as green and yellow and theoretically reach even orange and red, thus covering the entire visible spectrum.

The problem is that this material is very complex to work with. In fact, even before the first demonstration of the blue LED it was known that a blue LED could be fabricated with this material, but it was very difficult to achieve good *p*-type GaN material. The 2014 Nobel laureates were able to overcome this difficulty and since the early 1990s the capability of growing high quality GaN LED material has been demonstrated and it has become feasible to fabricate LEDs in a commercially viable way.

We can summarize the other main advantages of gallium nitride as:

- It has a good thermal conductivity, leading to simpler packaging with a reduction in system volume and weight.
- It operates at a lower supply voltage, and at a lower temperature and with increased light output.
- It has a faster switching speed and reduced electrical noise. This allows for the use of LEDs in optical communication systems.
- The materials are environmentally friendly, and no hazardous materials are required for the fabrication of devices.
- The material is robust, which results in long lifespan devices.

My research on GaN-based light emitting diodes

At this point it is clear that LEDs provide a nice solution to illumination problems and we have pointed out some of the unique properties of gallium nitride. Nevertheless, there are many things still to be researched: Gallium nitride is a complex material and some of the light generating mechanisms are still poorly understood. In fact, some of them have been the subject of debate for more than a decade and we still do not have conclusive answers.

On the other hand, we are able to produce efficient sources of white light because blue GaN-based LEDs have energy efficiencies of up to 85%. However, this is not true for green GaN-based LEDs where the highest efficiency is presently around 30%. If we move further towards yellow, and orange the efficiencies are even lower and no gallium nitride based devices are commercially available yet in these colours.

So, the main goal of my research is to improve the understanding of what makes this material emit light and how to maximize the emission efficiency in all the visible colours. A combination of electrical and optical excitation is used to get insight into the recombination processes of electrons and holes inside these materials. Also, different semiconductor growth techniques are compared to see the advantages and disadvantages of the various

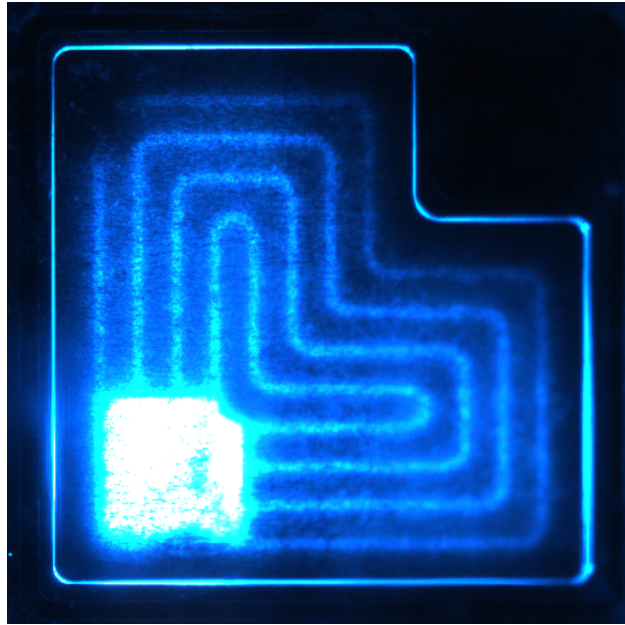

Figure 2: Microscope image of light output under electrical excitation for a blue LED fabricated at Tyndall.

crystallographic structures of GaN. With the aid of the processing facilities at Tyndall we can also investigate the effect of the device shape and the fabrication steps on the light emission of processed LEDs as illustrated in Figure 2.

Source: Author

Final words

We are just at the beginning of the LED era for general illumination. The knowledge developed in semiconductor fabrication and packaging is allowing us to fabricate science-fiction types of devices like flexible, miniature displays, holograms, virtual and augmented reality helmets and smart lamps which can change the intensity, colour, and direction of the light depending on the needs of the user. All of this is made possible by advances in semiconductor lighting technology and microfabrication processes.

A lot of work still needs to be done though. A better understanding is required to see what happens inside materials such as GaN to achieve even better light sources to illuminate our future.

I would like to thank my supervisors Pleun Maaskant and Brian Corbett and all the people from Tyndall National Institute for their support during my research, especially to the people belonging to the GaN group. I also would like to acknowledge funding by the European Community's 7th Framework Programme.

STEMming the tide of student non-engagement

Wissam Abdel Samad

School of Education, UCC

“If the structure does not permit dialogue the structure must be changed” (Paulo Freire)

Introduction

Ireland faces a crisis. The uptake of STEM subjects (Science, Technology, Engineering and Maths) at secondary levels is declining. Students are disengaging from these subjects at a growing rate. Research reveals that this disengagement happens early in the Junior Cycle when some students start to enjoy their schoolwork less as they move through the system. In Ireland there is an urgent need to counteract this decline. As Ireland becomes a global scientific hub, the market’s demand for a scientifically literate workforce is ever increasing. In a few years the demand on a scientifically literate workforce will surpass the number of science graduates. So is there a way to avoid this crisis?

In recent years, the Irish Government and the EU have committed to investing in the education of STEM subjects (Science, Technology, Engineering and Maths). The attention is now on developing strategies to improve science teaching. For example, the EU has an increasing interest in facilitating good practice in IBSE (Inquiry Based Science Education) to replace the traditional teaching methods of science.

So what is IBSE?

It is a problem-posing and student-centred teaching methodology. Students are faced with a problem, to solve it they have to construct their own knowledge by making observations, planning investigations and experiments, gathering data then analysing it and communicating the results. They deduct general theories from specific practices to advance their science literacy, critical thinking and problem solving skills.

Despite the considerable investment in IBSE that is designed to inspire young people interests in the sciences; the uptake of subjects such as Physics and Chemistry is still declining. It seems as if IBSE is missing an extra element to reach its potential in engaging students to a level where they uptake science subjects in the Senior Cycle.

Where are we going wrong?

To find out we *must* start to critically question the political and economic implications of the STEM education and its role in engaging students effectively and find alternatives. This is where my research comes in.

Research aim

Research found that culturally insensitive curricula have served to legitimize discrimination towards racialised, classed and gendered students by preventing them from enjoying full and active democratic citizenship and engagement.

This research focuses on the S in STEM. The main aim of this research is to develop a “Critical Inquiry Based Science Education” (CIBSE) curriculum by adding elements of Critical Theory to IBSE to stem the tide of student non-engagement. It questions the dominant discourse of STEM education. A Critical IBSE curriculum is a culturally sensitive curriculum that is relevant to students’ social lives. The cultural relevance is the degree to which the curriculum content and classroom experience speak to a student’s social self-identity (e.g. race, class, gender, sexuality and ability) through a problem-posing methodology that focuses on using real-world and locally meaningful situations. This research argues that a culturally relevant IBSE approach increases the students’ effective engagement and subsequently will have a positive influence not only on science subject uptake at secondary level but also on democratic citizenship.

This study aims to explore the effectiveness of CIBSE on increasing students’ engagement in STEM subjects and subsequently on STEM subject uptake, advance the teachers’ practical skills to implement CIBSE effectively and relate science education to teaching for citizenship and moral development. It will also study the effect of a culturally relevant science curriculum on students’ engagement

But the question remains; does the integration of CIBSE curriculum into Junior Cycle respond to the contemporary need in Ireland for both a scientifically literate workforce and a fair and equal society for young people?

Critical theory

To be able to understand what a CIBSE curriculum is, one ought to start by defining Critical Theory. Critical Theory is a theory that aims to ‘humanise’ students by treating them as ‘subjects’ who have the ability to change their circumstances rather than just objects who are made to follow orders. It is a framework of belief systems that directly engages members of culturally diverse groups with a focus on social justice issues. This approach includes the perspectives of the participants (the students and the teacher) and the structures within which their interactions take place (the school and the classroom). It

aims to improve the students' social awareness about issues of recognition, representation, and power relationships. It focuses on dialogue to interrogate dominant views and what is accepted as 'common sense'.

Rationale

Recent rapid changes in the world economy have highlighted the need for a workforce that is scientifically literate. However, there is a steady decline in the proportion of young people taking science subjects within upper secondary education. Traditional didactic learning remains dominant in our education system. Research found that science take-up tends to be higher in schools which emphasise practical work and students' participation in classroom activity. Active learning is currently being promoted in the new reforms to the Junior and Senior Cycle. The European Commission regards pedagogical practices based on inquiry-based methods as more effective for the teaching and learning of science. It has identified gaps in knowledge related to the necessary pedagogical skills needed by science teachers to promote teaching and learning environments for IBSE and to implement it in their classrooms more effectively. This research aims to bridge this gap by providing in-depth evidence of the processes and skills needed for a more effective implementation of IBSE.

Research suggests that didactic practices limit the students' effective engagement in the learning process. The disengagement of students has subsequent societal costs tending to reproduce social inequalities between middle and working class students. Crucially however, my study also suggests that the current trend towards IBSE is in danger of underestimating the complex factors involved in enhancing student engagement, citizenship and participation. However, by developing a Critical IBSE curriculum, this research study provides a concrete way of offering lower-income and disaffected students a greater opportunity to shape the discourse of science and reflect on its social, economic and political priorities, rather than solely introduce them to basic scientific concepts and methods.

Objectives

This research argues that engaging students in creating their own culturally reflective Inquiry Based Science Education curriculum (CIBSE) increases their engagement and subsequently their uptake of science subjects at secondary level. Together the students and I (researcher/teacher), identify and co-investigate scientific themes that are relevant to the students' own culture. This approach not only develops scientific literacy but also equips students with critical thinking skills and a sensitivity to issues of social justice.

The key objectives of this research are to explore the current levels of students' engagement in STEM subjects, incorporate students' social realities into the co-creation of a

science curriculum and deploy it and to explore how the new curriculum opens up opportunities for meaningful student engagement and enhanced science literacy. This study assesses the students' emerging skills of enhanced science literacy, critical thinking and democratic citizenship and their effect on meaningful engagement and devises effective and meaningful strategies for science teachers to confidently deploy an innovative, creative, and culturally-relevant CIBSE curriculum which simultaneously addresses science literacy and social justice related issues. The final objective is to create guidelines for a better understanding of inclusionary practice and social diversity through 'science learning'

Methodology

I, the researcher who is also a qualified science teacher, will co-investigate and co-develop a CIBSE curriculum with a group of Transition Year students. It is a science curriculum that is owned by the students rather than being imposed on them by the teacher. It deals with scientific themes that are relevant to the students' own culture, gender, class, sexuality, ethnicity and ability. This curriculum challenges dominant social views about the teaching and learning of science as 'objective' and 'neutral' knowledge and locates it in its wider political and economic context towards a more inclusive and socially aware classroom. It explores how students are empowered (or disempowered) by science education. It is a methodology where both teachers and students inquire, learn and teach interchangeably; they advance through mutual dialogue towards becoming critical, scientifically literate and democratic citizens. Even though this research encourages students' autonomy in setting up the curriculum, the teacher's role is crucial in guiding this process.

This methodology will argue that an apolitical approach to science education is in itself a political act in which educators are consciously or unconsciously involved in serving the interests of the 'dominant group'. For example an uncritical science teacher could play a key role in justifying an exploitive economic and political system, ignore the scientific contribution of non-Western scientific traditions and attribute people's hindered achievements to biological or geographical factors. Hence, an uncritical teaching and learning of science, as currently practiced, inevitably engages the teacher and learner in maintaining structural social injustices. The process of co-creating a CIBSE curriculum with the students through dialogue insures the representation of both the dominant and marginalised views to empower and engage both groups.

The choice of the Transition Year cohort as research participants is justified by the following:

- CIBSE is closely related to modular development in Transition Year. CIBSE gives the students a greater opportunity to shape the discourse of science and reflect on its social, economic and political priorities, rather than solely introduce them to basic scientific concepts and methods

- The Transition Year is a key year for the students to revive their engagement with STEM subjects influencing their up-take decision in 5th year
- Research findings and recommendations would help re-shape the emerging Junior Cycle curriculum

In order to examine the main research question about the impact of a CIBSE curriculum on students' engagement, data is collected through: pre- and post-research assessment interviews; the teacher's informed observations and weekly self-reflective journaling; and students' periodic self-evaluations, as part of the 'assessment' process. A comparative thematic analysis is conducted in relation to behavioural, cognitive and affective engagement before and after the research takes place as follows:

- Behavioural engagement:
 - Social engagement
 - Academic engagement
- Cognitive engagement focuses on students' efforts put to comprehend complex ideas
- Affective engagement is examined through studying feelings of identification and belonging to the school environment and the wider community

Social identities such as those related to class, race, ability and gender are always re-produced, defended, challenged and reconstituted in schools as they are affirmed or dismissed at different times and in different contexts within educational settings. Hence the co-creation of a CIBSE curriculum and data analysis will be done in the light of the contemporary concept of 'intersectionality'. Intersectionality is a concept that maps the intersections of race, gender, class and ability and disrupts the tendencies to see them as exclusive or separable when addressing key issues related social injustice. This research will use this concept as a tool to uncover the shifting interplay of inequalities facing students at subcultural, peer and institutional level.

The data collected is qualitatively analysed highlighting the development and the transformation of the process and the challenges and limitations faced. Based on the data analysis, recommendations are given.

Methods

This research is conducted in two schools with the Transition Year cohort. It includes the following methods

- Observations: Two one-week observations — one week within each school observing Transition Year Science classes

- Semi-structured interview: Twelve Semi-structured interviews — four science teachers and two school principals — pre and post research
- Focus Groups: Four focus groups — pre and post research assessment interviews — two within each school
- Age appropriate, methods is used to stimulate discussion
- Two terms of teaching Transition Year Science classes during which CIBSE modules with extensive ICT resources are co-created and co-developed with the students
- In line with the principles of critical enquiry and driven by its participatory approach, this research accentuates the voice of young people as central to the project. A students' advisory group provides input to the methods and feedback on initial data analysis

Conclusion

Concerns have been expressed regarding the declining interest in science. The manner in which science is taught in junior cycle contributes to the fall-off in the take-up of science subjects at senior cycle, with follow-on impact at third level. The lack of interest in science education, particularly its perceived lack of relevance and abstraction, seems to be a particular concern identified by the European Commission. This research not only identifies gaps in knowledge regarding STEM education, but also conceptualises a pedagogy that increases students' engagement in STEM subjects at a secondary level and subsequently develops STEM skills needed for a scientific workforce in the current Irish economy. Furthermore it questions the effects that 'teaching for the market's need' has on students' identities.

The findings of this research are crucial on national and international level. They contribute to knowledge methodologically as this kind of research is under-used in Irish contexts. Empirically, they give insight into the context of Junior Cycle reforms and the social and political issues around it particularly for marginalised students. And finally this research conceptualises the processes through which curricula could be co-created for social justice progress.

The Author wishes to thank his supervisors Dr Stephen O'Brien and Kevin Cahill and his colleagues.

Alien versus native: The fight for free space

Mary Catherine Gallagher

School of Biological, Earth and Environmental Sciences, UCC

“The truth is: the natural world is changing. And we are totally dependent on that world. It provides our food, water and air. It is the most precious thing we have and we need to defend it.” (David Attenborough)

Invasive species

It is easy to forget that we live on an island. Even though we have recently become a lot more aware of where our food comes from, we don't really think about how it gets to us. In Ireland, 95% of our imports and exports are transported by ships, but it is not just cargo that these vessels can move. Plants and animals can grow on the outside of ships, or survive in ballast water, which keeps ships steady, but is almost like a travelling aquarium. It has been estimated that there are up to 10,000 species being moved around the world every day — Just in the ballast water of ships!

Only some of these species will survive the journey to a new region, and not all of those will be able to become established in their new environment. However, for those alien species that can survive in a new area, they have the potential to thrive. In the absence of their natural predators and competitors, these species can grow and reproduce at rates that allow them to outcompete native species and reduce native biodiversity. Scientists have described invasive species as one of the greatest threats facing ecosystems globally — but what does that really mean and how can they impact our daily lives?

Ecosystem services

Ecosystems provide us with services which are vital to our survival and well being, but often go unnoticed. The air we breathe, the water we drink, the soil that we grow our food in and the pollination of our crops, are all provided by ecosystem services. Invasive species threaten these services, by reducing biodiversity through competition, changing the way our ecosystems work and the services they give us. Along with these ecological implications, invasive species can also have economic impacts. In the Black Sea, the accidental introduction of a predatory sea gooseberry (a small jelly-like animal) led to a depletion of anchovy fish stocks. The sea gooseberry was consuming the eggs and juvenile stages of the anchovies and also food which would have been eaten by the anchovies themselves. Not only did this change the structure of the ecosystem, but reduced the abundance of anchovies, depleting fish stocks, the value of the fishery and the number of people it employed.

My research

My research is focused on an alien species of barnacle (Figure 1), which is native to Australia and New Zealand. It was introduced to European waters in the 1940s through shipping, and is now widespread on European coasts. It is only in recent decades that increases in its abundance have been recorded within its invaded range. This time lag has meant that little is known about how this species competes with native species and how its presence might alter ecosystem function. I am hoping to answer these questions, along with trying understand what the factors controlling the current northern and southern invaded range limits of this species are, and how future climate change might alter the abundance and distribution of this species in comparison to natives.

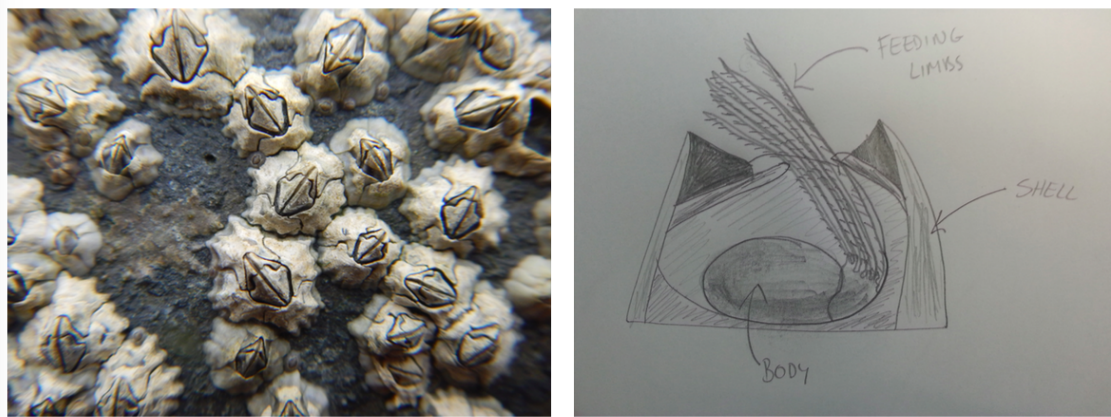

Figure 1: Photograph of study species (left) and drawing of barnacle structure (right) (Photograph and illustration are author's own).

Why barnacles?

Firstly, what is a barnacle? Have you ever been walking barefoot on rocks at the sea side, and felt something uncomfortable underfoot? When you look down you notice that the rocks are almost carpeted with very small shells — these are barnacles! Each of these shells is basically a house, with a little shrimp-like creature living inside, lying on its back. When the tide comes in, it kicks its legs into the water to grab food, through movable doors on top of the shell (Figure 1). They are amazing animals and Charles Darwin himself spent 8 years studying them — though apparently he was happy to move onto a new subject after that! Because barnacles are small, occur in large numbers and stay in one place, they have been used as “model” organisms for ecological studies. This is one reason why I chose to study an alien barnacle species. Also, it is thought that recent increases in the abundance of this alien species are due to environmental changes, in particular water temperature. My study species is warm water adapted, and it's possible that predicted increases in seawater temperature could promote the abundance of this, and other warm water alien species in our cold temperate waters. Potentially there could be many alien



Figure 2: Photographs of the same removal plot in April 2014, September 2014 and January 2015. The invasive species is visible in September 2014 and January 2015 as the grey coloured individuals, while the natives are more white in colour.

species lying dormant in our cold temperate waters, surviving but not becoming abundant until environmental conditions become more suitable for them.

Marking your territory

Space is a limited resource in lots of habitats, and the sea shore is no exception. The community composition of different areas is dependent on the outcomes of competitive interactions between different species. Invasive species are known to be able to rapidly make use of free space, helping them to become dominant in communities and to take over new structures placed in the marine environment, like piers and marinas. To gain a better understanding of how this invasive species competes with natives for space, I created experimental removal plots at seven different sites on the south-west coast of Ireland. These plots were scraped clear of all barnacles and scrubbed with wire wool to ensure that there were no animals left on the rock. Then I visited these sites, every month for over a year to see how the space was colonised over time.

But first we take a selfie

Each time I visited my field sites, I took photographs of each plot (Figure 2). Then, back in the office I analysed these images and compared them with those of the previous month to look at the survival of native and invasive individuals that had settled in the free space, count any new barnacles that had settled in the plots and also to measure their growth.

Invasive versus native

Lets take a closer look at the competitors and their strengths and weaknesses. When barnacles reproduce, they release their larvae into the sea and then after a time these larvae settle on hard surfaces on the shore. The invasive species has the potential to

reproduce throughout the entire year. Individuals are able to produce multiple broods in one year and can become mature at just ten weeks old. On the other hand, for our two native species, breeding is restricted to specific times during the year (Spring and early Autumn), though they usually reproduce in large numbers. New native individuals, cannot reproduce the same year that they settle on the rocks.

As I started my study in the spring time, initially I recorded a native species in my plots. Then, after a couple of months, the invasive species began to establish and increase in abundance (Figure 2), followed by the second native species in early Autumn at some sites. Overall, the invasive species became the dominant barnacle in removal plots at four out of seven of my sites. However, when you look at the abundance of invasive species in relation to native species in the removal plots, compared with their abundances in the overall community at each site, providing free space only allowed the invasive species to become more abundant at three of the sites.

Even though the invasive species was dominant at most sites, the native species was still able to settle in the free space and survive. While, it is worrying that the invader dominated overall, it is interesting to see that it was not highly abundant at all sites, and that there are certain factors which inhibit its establishment at some locations. Looking at the starting community composition of my sites, it seems that the invasive species needs to be present in high abundances, to be able to dominate free space which becomes available. Even though invasive species are usually recognised as being superior competitors, I have found that is not always the case. The fact that native species were able to settle and survive in plots, even where the invader dominated, would suggest that it could be difficult for the invasive species to entirely outcompete and displace our native barnacle species.

Here to stay

There is no doubt that this invasive species is here to stay, however it seems that in many locations the native species are too! Evidence from my removal plots shows that even where the invader dominates, native species are capable of surviving too. However, the reverse was not true for sites with very high abundances of the native species. Although this invader is known to be able to rapidly settle on and dominate new structures in the marine environment, it is clear that timing is very important in this. If a new structure is built during the summer it will be dominated by the invasive species, but if it is built in the early spring, chances are it will initially be colonised by a native species, and then subsequently there would be settlement of the invader creating a more diverse community.

If there is a change in environmental conditions, like a change in temperatures, or a year where the native species fail to reproduce, it is possible that the invasive species will increase in abundance and displace native species. If this is the case, it could have worrying implications for the ecosystem. The larvae of barnacles provide an important food source for animals in the sea, including commercially important fish. If this invasive

species outcompetes the native species, the abundance and timing of this food source would change, with implications higher up the marine food chain, changing biodiversity and ecosystem function! Thankfully this is not the case at the moment, as the native species remain dominant at some locations and are still present at most sites where the invader prevails. However, in order to ensure that this will still be the case in the future, it is important to try to conserve our native species and conditions which are favourable for their survival, helping them in the fight for free space against these alien invaders.

I would like to thank my supervisors Dr. Ruth Ramsay, Dr. Rob McAllen and Dr. Sarah Culloty. This PhD research would not be possible without funding provided by the NUI Travelling Studentship and the UCC Strategic Research Fund.

Surviving in uncertainty: experiences of recession in Knocknaheeny, Cork

Sander van Lanen

Department of Geography, UCC

The larger context of economic insecurity and cultural uncertainty in which young working-class men and women come of age is restructuring the kinds of adults they are growing into. (Jennifer M. Silva)

Introduction

Memories of being sent home from a construction site, parents who suddenly struggle to make ends meet, moving back into ones parental home, but also the feeling that nothing has really changed at all. These are some of the experiences young adults in Knocknaheeny have of the 2007 financial crash and the following recession. Knocknaheeny is an area described as deprived, with more than one in four unemployed, while 40% of those employed are semi- or unskilled and about a third of the population has finished primary education only. A neighbourhood where some parts benefited from the property boom of the 2000s while others are third generation unemployed. It is the neighbourhood in which the first part of my research on the experiences of recession by disadvantaged urban youth takes place.

I am not the first to write about austerity, increasing uncertainty and impacts of the recession on different aspects of life in Ireland. Both academic and non-academic publications have dealt with these issues massively, and the crisis and its aftermath is still an almost daily topic in newspapers. Most of the attention, though, focusses on relatively well off segments of society; university students that can't find a 'real job' and have to take on unpaid internships, skilled workers who can only guarantee temporary contracts and college graduates working call centres and coffee shops. But what about those for whom stable employment maybe never was on the horizon? Low skilled workers were the first to be laid off, those dependent on social welfare feel the cuts in spending directly and those without further education now have to compete for semi-skilled jobs with those who went to college. It is their experiences I am interested in, and it is for this reason that I selected Knocknaheeny in Cork and Ballymun in Dublin as my research sites.

Phenomenology

To investigate the impacts of the recession on the everyday life of young urban adults I use a phenomenological approach. Alan Bryman describes phenomenology as “a philosophy

that is concerned with the question of how individuals make sense of the world around them". It recognises that social reality has meaning for people, and that this meaning guides their behaviour. It is from this recognition that it aims to interpret people's actions and their social world from their perspective. The phenomenological interview gathers description of a participant's lifeworld relating to the interpretation and meaning of a certain phenomenon, which is crisis and recession in this research. These personal experiences and meaning that the participant allocate to the phenomenon are at the heart of the interview and the aim is to understand the meaning of crisis and recession within the reality of the participant, to see how the world appears to the interviewee. The main focus is on the relation between the participant and the theme of research, and the participant's experience of the recession.

In total I conduct in between 15 and 20 interviews with young adults, aged between 18 and 25, from Knocknaheeny, Cork. Interviews start with general questions about the participants' experience of recession and when and how they felt its impacts, and if and how this changed their behaviour and experiences in everyday life. After this, I use follow up questions to get information on all the topics I am interested in. To make sure the information stays as close to the personal experience as possible I use the language used by the participant. This ensures that they use vocabulary they are most familiar with, and creates an atmosphere in which the participant feels confident to share their story. I make sure I talk to them afterwards and ask how they felt about the interview, to receive feedback, reflect on my practice and improve interviews to come.

Interviews are not the only method used, they will be followed up by 'walking tours' with some of the participants. Here they will show me around their neighbourhood while we have a conversation about the impacts of the recession on their everyday lives. Through this method it is possible to better ground these experiences in space while it also allows me to observe how participants interact with their surroundings and others living in the area. Not everyone agrees to participate in this, but sometimes even this rejection leads to valuable information, as a 20 year old woman told me she would like to, but cannot as she almost always has to babysit the various children in her extended family after work.

The lifeworld

Limiting the influence of the recession to the labour market and the financial situation of people would deny the totality of its impacts. Although these are the most straight forward and direct ways in which people are affected, increased insecurity related to a loss of income and more precarious working conditions permeate into almost every aspect of people's everyday life. It is for this reason that I deploy the concept of the lifeworld, described by Anne Buttmer as "the cultural defined spatio-temporal setting or horizon of everyday life". It is the lifeworld that contains the choices and options one has in everyday life, and it is defined by the complex interactions of time, material conditions and cultural

values and expectations. Increased insecurity in several parts of one's life can severely impact one's lifeworld, and it is these changes I am looking for.

The lifeworld imposed by external factors can have clear physical boundaries. For example, a 24 year old male from Knocknaheeny described how he could not visit his family as often as he wanted.

“My dad lives down in Douglas as well, so my little sister again, she's only four, and I don't get enough time to see them at all. I'm living too far away. My other sister lives down in Cobh and I never get to see her. I never get to see my sister down in Fermoy, never ever get to see my brother up in Dublin. It's all money, they don't have money, I don't have money, so, that's kind of hard, like.”

Here financial and spatial factors combine and prevent him from visiting his brother and sisters, who, he expressed elsewhere in our interview, are very important to him. Family comes up as important in almost all of the interviews, a lot of people want to get employment to be able to help out 'at home'. Most of the people I interviewed donate towards family expenses even when on a very low allowance themselves.

A 26 year old man told me he lives in a homeless hostel by choice, but that choice is once again structured by external factors. He is unable to afford accommodation in Cork City, and is aware that he would be able to afford a house outside of the city, but as he does not own a car he would be unable to access the casual jobs that he works every now and then. Here the interplay of transport possibilities, labour market accessibility and housing shape the horizon of this man's actions and decisions.

The impacts of the recession also overflow into people's social world, as their limited movement in time and space, due to limited financial means and options, prevents seeing friends in ways people used to. Above it was already mentioned how one participant can no longer see his family as much as he wanted, a 20 year old woman told me she regularly lies to her friends that she doesn't want to go to the cinema, because she hates it when they offer to pay for her tickets.

“It's hard, because you can't really do anything anymore, like, you used to be able to do fun things with your friends, like go shopping, and cinemas and that, but you can't anymore.”

But the lifeworld is not only a limiting factor, it is also the areas in which relations develop. Although sometimes caused by an inability to move out, many of the participants have most of their friends and families live within walkable distance from their house. Having lived in the area for most of their lives, people have a dense network of contacts within the area. Almost every participant talks about help and support coming from these networks, varying from babysitting each other's children, sharing rides to work and town, and helping each other out if necessary.

What about the future?

For my research I work with people aged 18 to 25 years old, focussing on those that (tried) to enter the labour market after the start of the recession. Since I work with young adults, the future is an important aspect of our conversations. As became clear in many of the interviews, the recession not only caused an increasingly insecure present, but it multiplies when it comes to plans and expectations for the future. As another 24 year old male expressed “Before you can start thinking of those things [a girlfriend and a family], you got to have stability in your life”. He was not the only one who expressed that he felt stuck, that he could not make the development he wished for, as another one said:

“My parents, they told me when they were younger they were out living by themselves at 18, starting families at 22/23, and here I am, 24, still at home, doing the same thing, just different day.”

It is the absence of stability, of a regular income, that makes it impossible for these young adults to move out of their parental home, to start a family, to make plans for the future. This makes some of them feel like their future is put on hold, they are not developing, but always waiting for something to happen and move on.

Since this is a generation that comes of age in an era of austerity and precariousness, it shapes what kind of adults they become. Through the study of the changing lifeworld of disadvantaged urban youth I will shed light on how insecurity gets embedded in relations formed within these individual’s communities, and how it impacts their relation to their neighbourhood and the state. Understanding how coming of age after the crash influences individuals helps to think about the kind of policies and support that might be necessary for those at the receiving end of austerity, and how current policies shape the Irish society of the future.

In the near future I will complement my interviews in Knocknaheeny with another form of data gathering. This will take the form of a walking tour, where participants show me around their neighbourhood while having a conversation about the impacts of crisis and austerity on their everyday lives. This allows me to clearly ground their stories in space, while observing how they interact with their environment. I will also perform interviews and walking tours in Ballymun, Dublin, to get a clearer understanding of the recession’s impact in Irish cities, and look for similarities and differences between disadvantaged areas within Cork and Dublin. After analysing and comparing the different methodologies and cities I can give a clearer answer to how the recession changes the lifeworld of young urban adults. Investigating changes in lifeworld, individually and communally, provides insight in how marginalized and vulnerable populations experience life in times of crises. In this way this investigation will contribute to an understanding of austerity’s impact on everyday life, the spatial, social and cultural effects of increased insecurity, and the way in which neoliberalism gets embedded and/or contested in everyday lived experiences. By providing a finer understanding on the direct and indirect effects of austerity and crisis

politics the outcomes of this work can provide valuable information for support organisations and community groups, and inform policy makers trying to alleviate concentrated poverty and deprivation. However the research will be used, one thing is certain: the future is unsure.

I would like to thank my supervisors Dr. Denis Linehan and Dr. Therese Kenna for their feedback and support. I would also like to acknowledge the Department of Geography, UCC, for the funding received for this project.